



US009715088B1

(12) **United States Patent**
Yang

(10) **Patent No.:** **US 9,715,088 B1**
(45) **Date of Patent:** **Jul. 25, 2017**

(54) **PHOTOGRAPHING OPTICAL LENS SYSTEM, IMAGE CAPTURING APPARATUS AND ELECTRONIC DEVICE**

(56) **References Cited**

U.S. PATENT DOCUMENTS

(71) Applicant: **LARGAN PRECISION CO., LTD.**,
Taichung (TW)
(72) Inventor: **Shu-Yun Yang**, Taichung (TW)
(73) Assignee: **LARGAN PRECISION CO., LTD.**,
Taichung (TW)

542,122 A	5/1895	Taylor	
2,522,390 A	9/1950	McCarthy	
3,051,052 A	8/1962	Bergstein	
4,806,001 A	2/1989	Okabe et al.	
5,162,947 A	11/1992	Ito	
5,610,767 A	3/1997	Ito	
6,014,265 A	1/2000	Kato et al.	
2012/0194917 A1	8/2012	Chen	
2015/0346459 A1*	12/2015	Chen	G02B 13/0045 348/335
2016/0041382 A1	2/2016	Kanazawa	

(*) Notice: Subject to any disclaimer, the term of this patent is extended or adjusted under 35 U.S.C. 154(b) by 0 days.

FOREIGN PATENT DOCUMENTS

(21) Appl. No.: **15/223,095**

JP	H05297270 A	11/1993
JP	H06242369 A	9/1994
JP	H07181387 A	7/1995
JP	2001100092 A	4/2001
JP	2009151046 A	7/2009
JP	2015121649 A	7/2015

(22) Filed: **Jul. 29, 2016**

* cited by examiner

(30) **Foreign Application Priority Data**

Jun. 4, 2016 (TW) 105117751 A

Primary Examiner — James Jones

(74) *Attorney, Agent, or Firm* — McClure, Qualey & Rodack, LLP

(51) **Int. Cl.**
G02B 3/02 (2006.01)
G02B 13/00 (2006.01)
G02B 9/62 (2006.01)
G02B 13/04 (2006.01)
G02B 27/00 (2006.01)

(57) **ABSTRACT**

A photographing optical lens system includes, in order from an object side to an image side, a first lens element, a second lens element, a third lens element, a fourth lens element, a fifth lens element and a sixth lens element. The first lens element has negative refractive power. The second lens element has an image-side surface being convex in a paraxial region thereof. The third lens element has positive refractive power. The fourth lens element has negative refractive power. The sixth lens element with negative refractive power has an object-side surface being concave in a paraxial region thereof and an image-side surface being planar or convex in a paraxial region thereof.

(52) **U.S. Cl.**
CPC **G02B 13/0045** (2013.01); **G02B 9/62** (2013.01); **G02B 13/04** (2013.01); **G02B 27/0025** (2013.01)

30 Claims, 24 Drawing Sheets

(58) **Field of Classification Search**
CPC G02B 13/0045
USPC 359/713
See application file for complete search history.

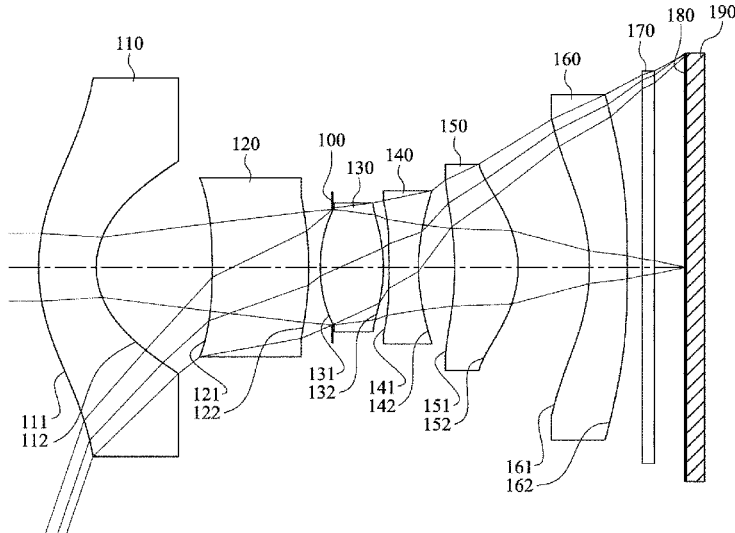

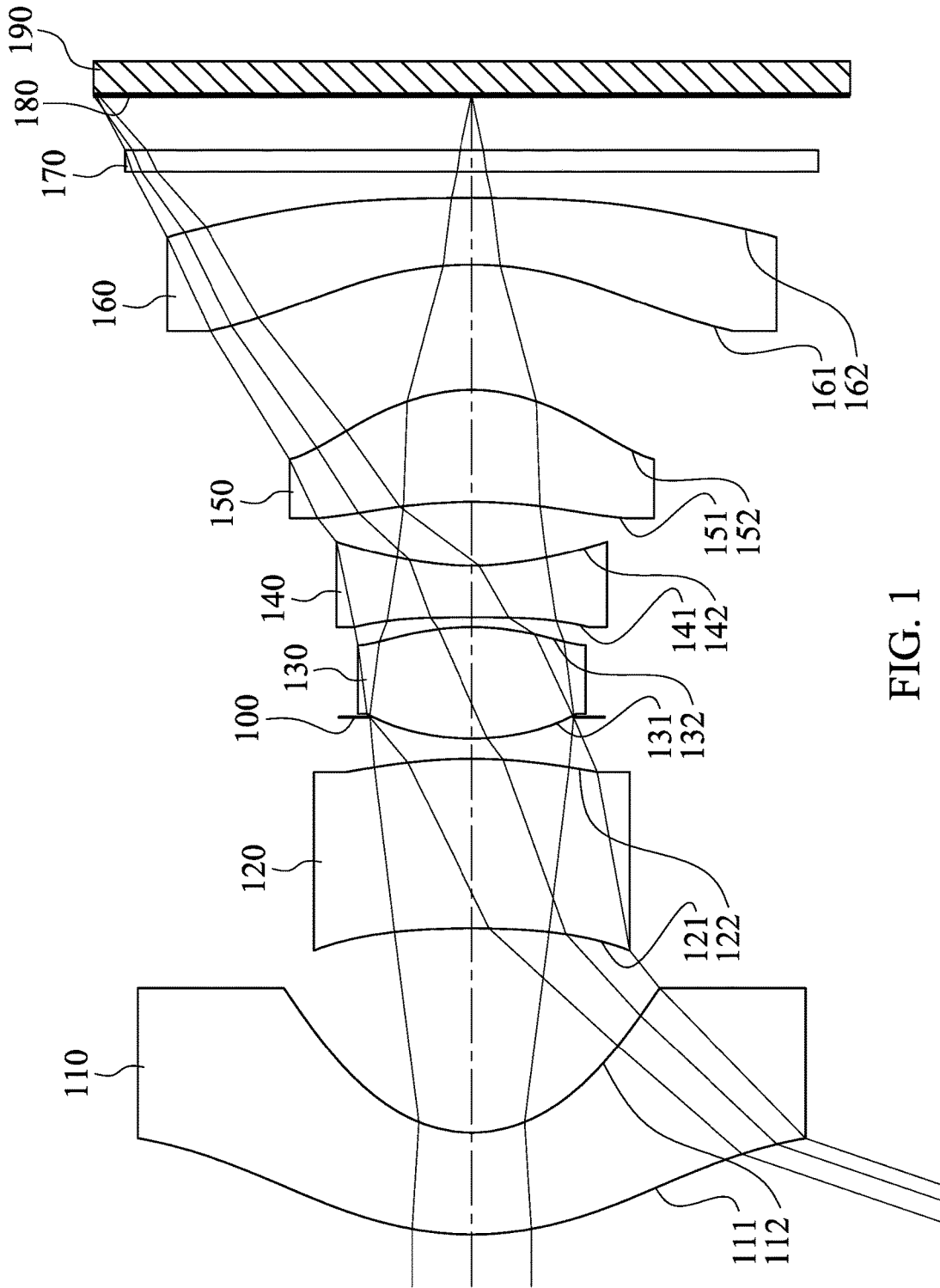

FIG. 1

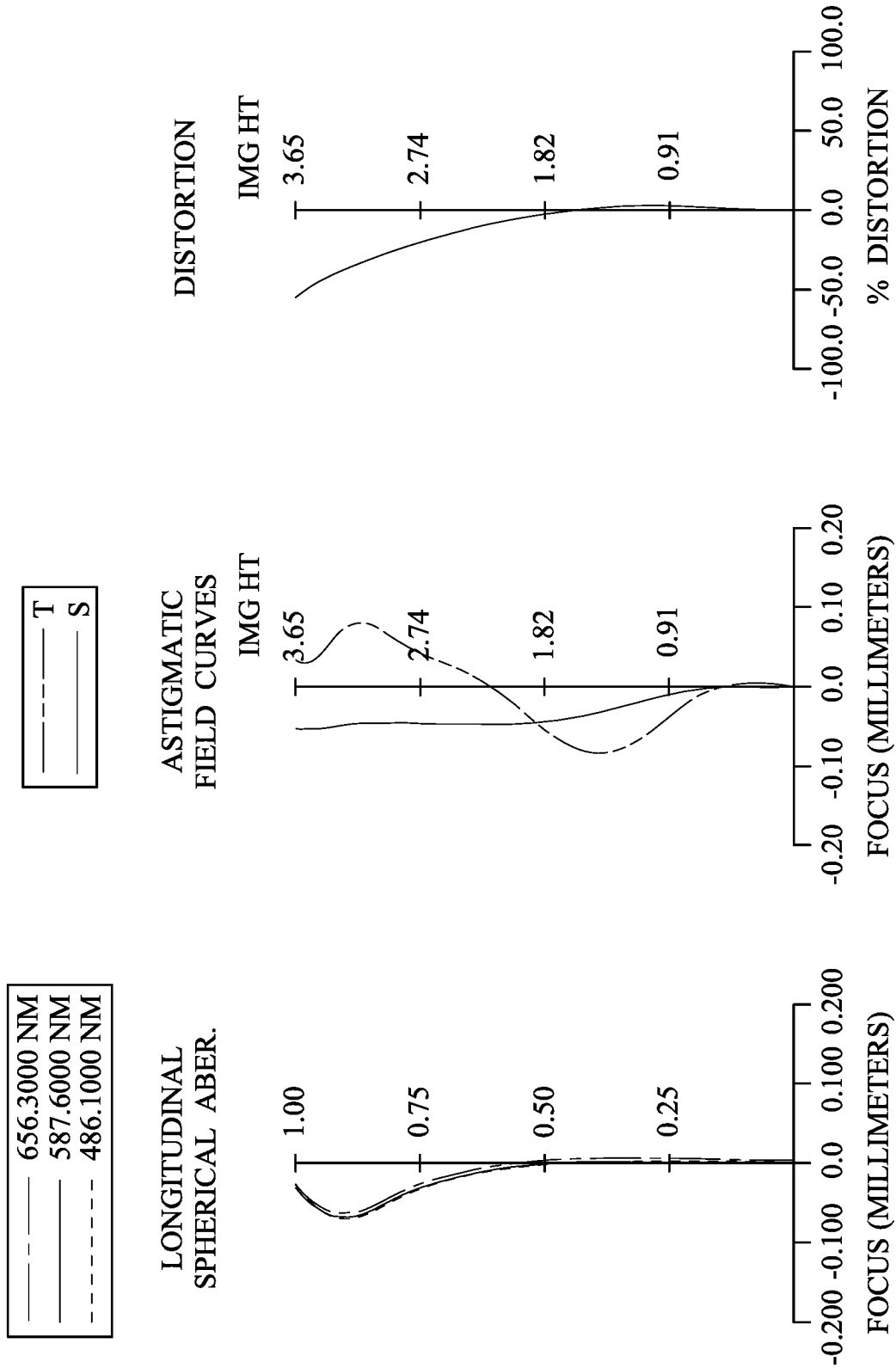

FIG. 2

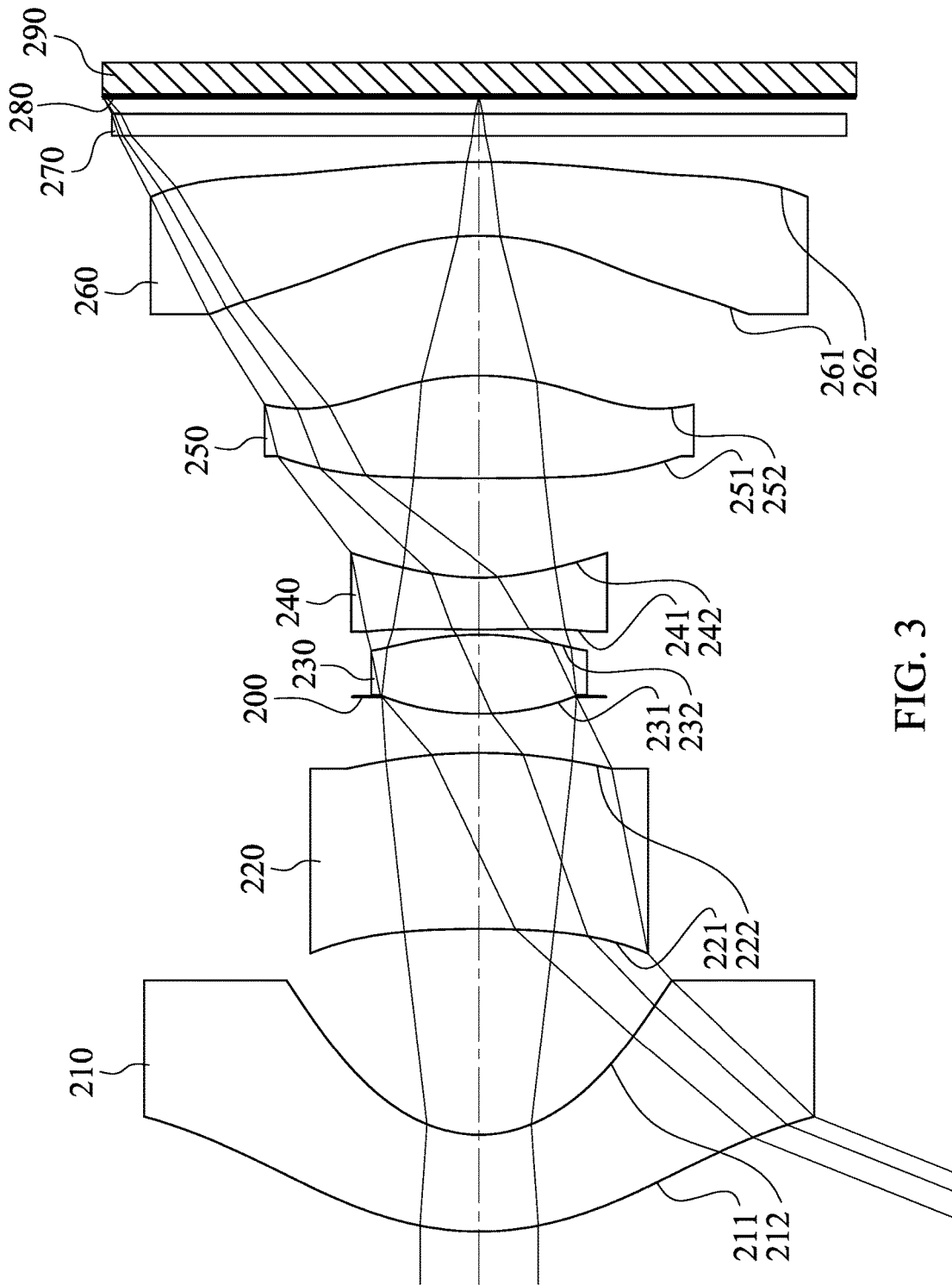

FIG. 3

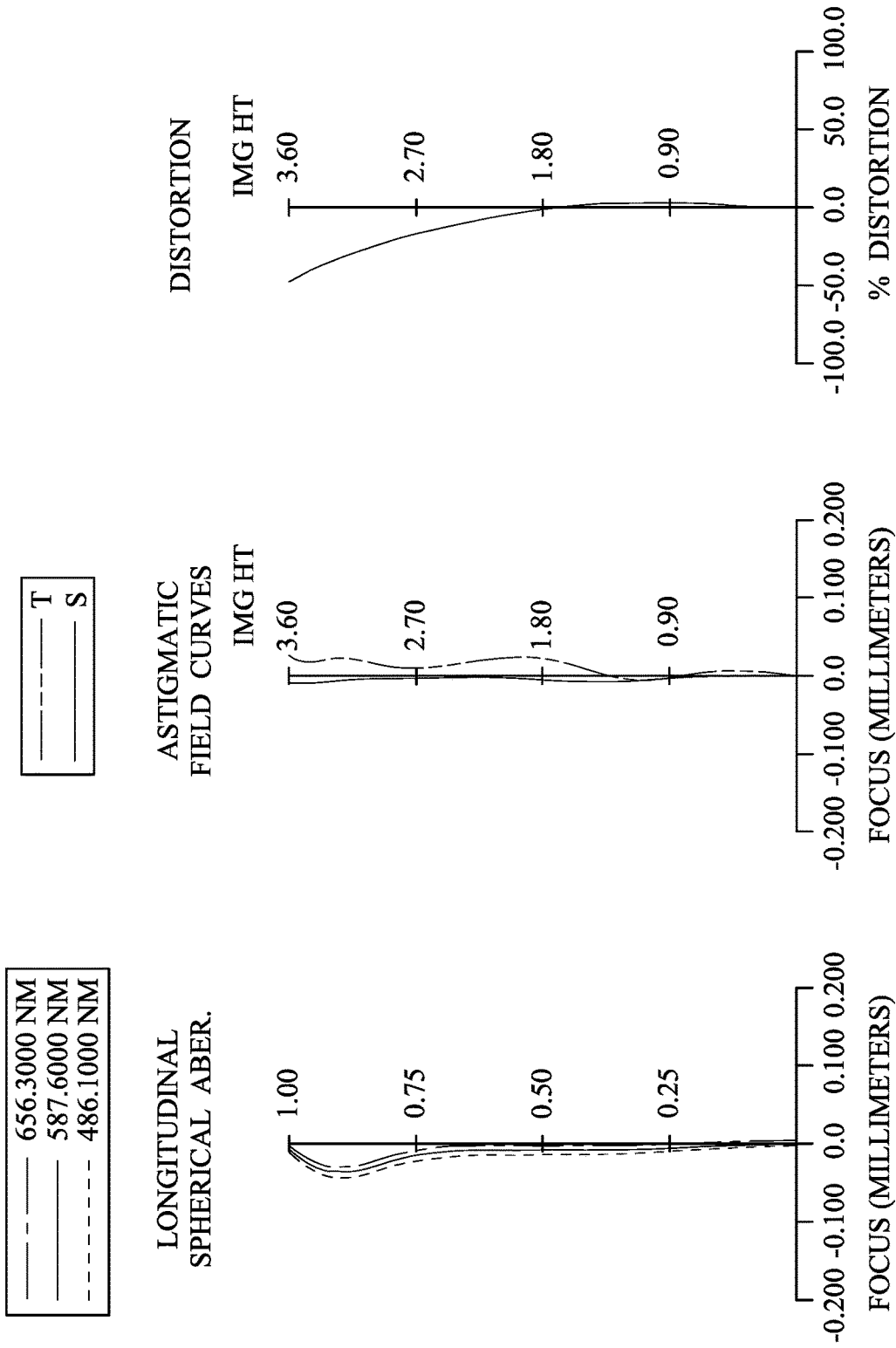

FIG. 4

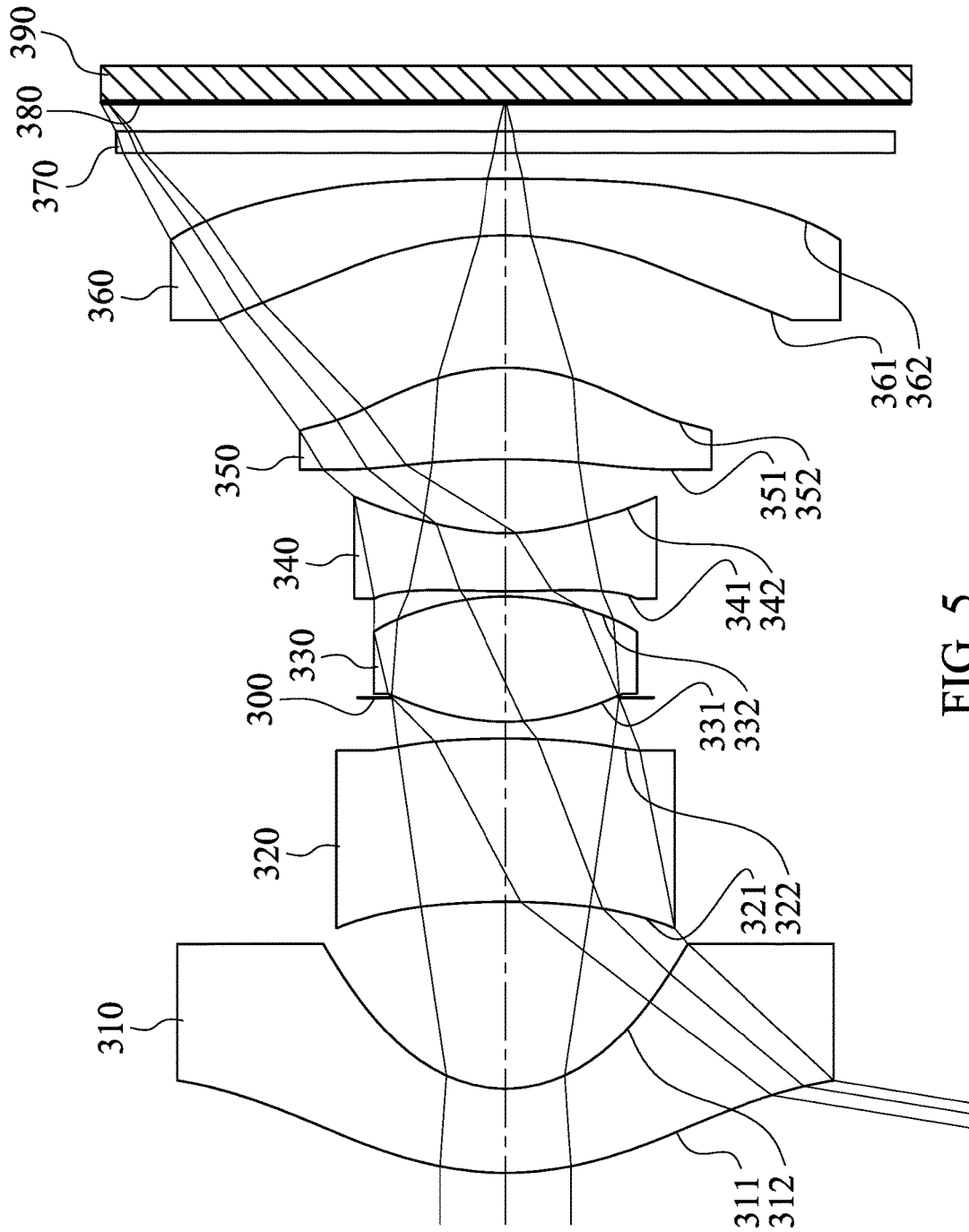

FIG. 5

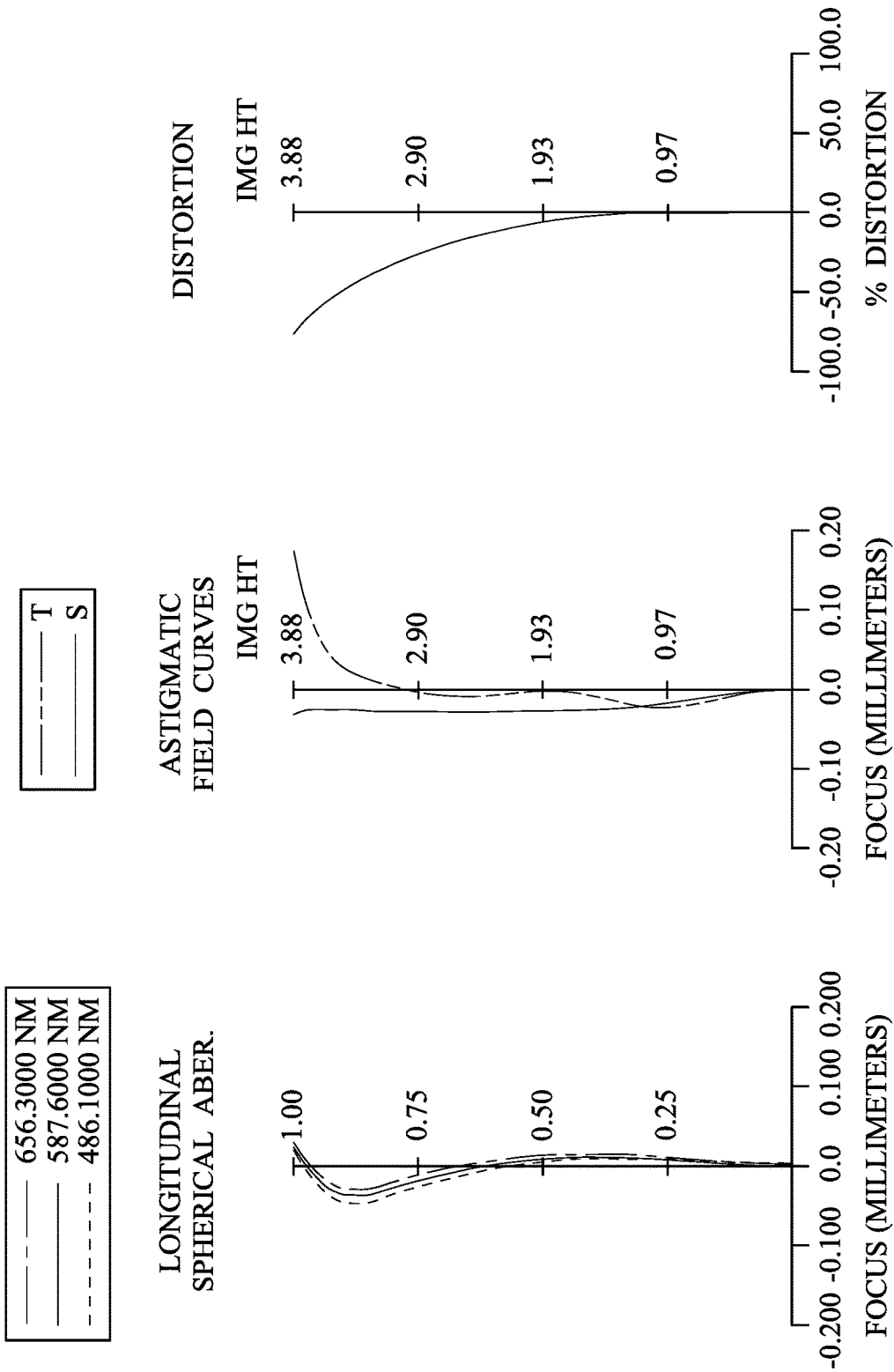

FIG. 6

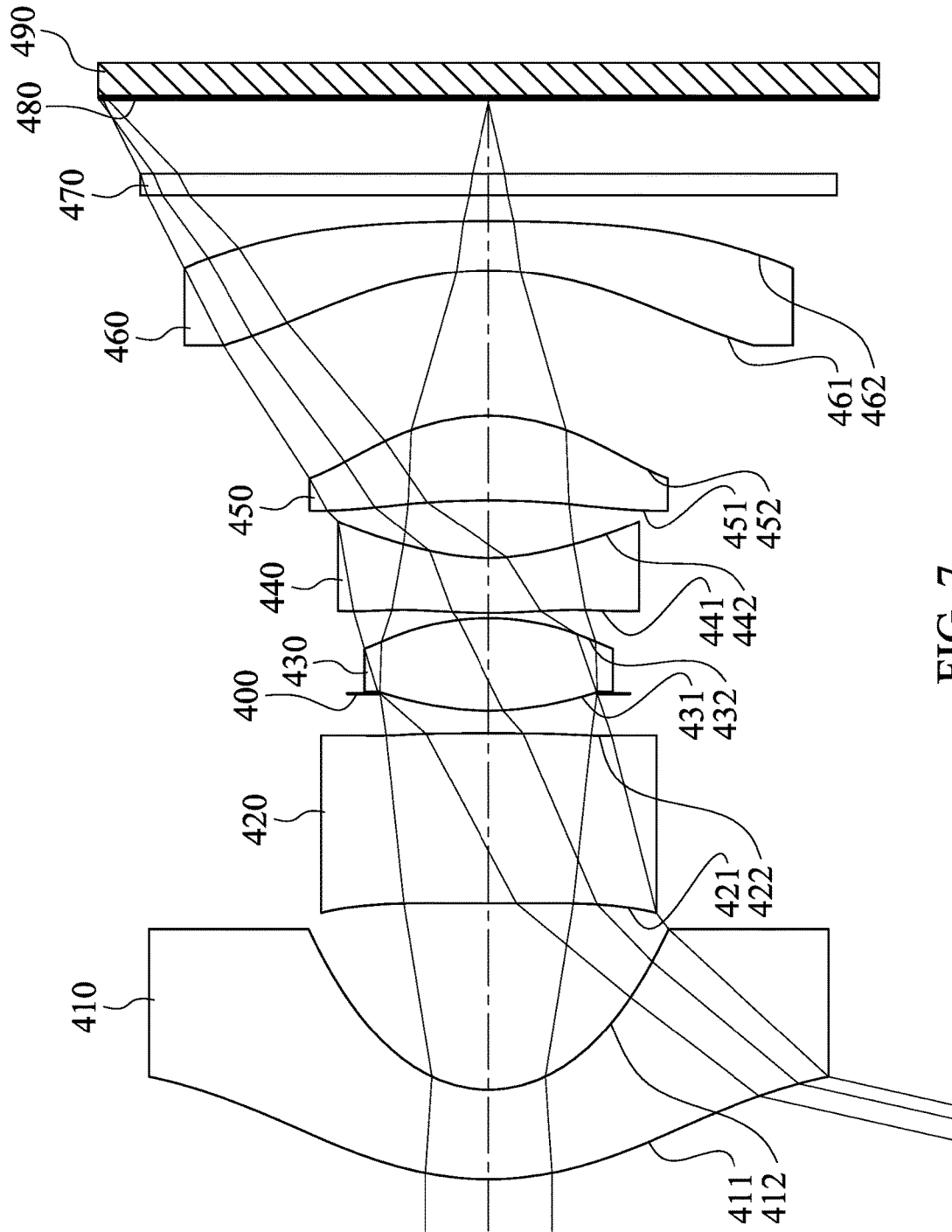

FIG. 7

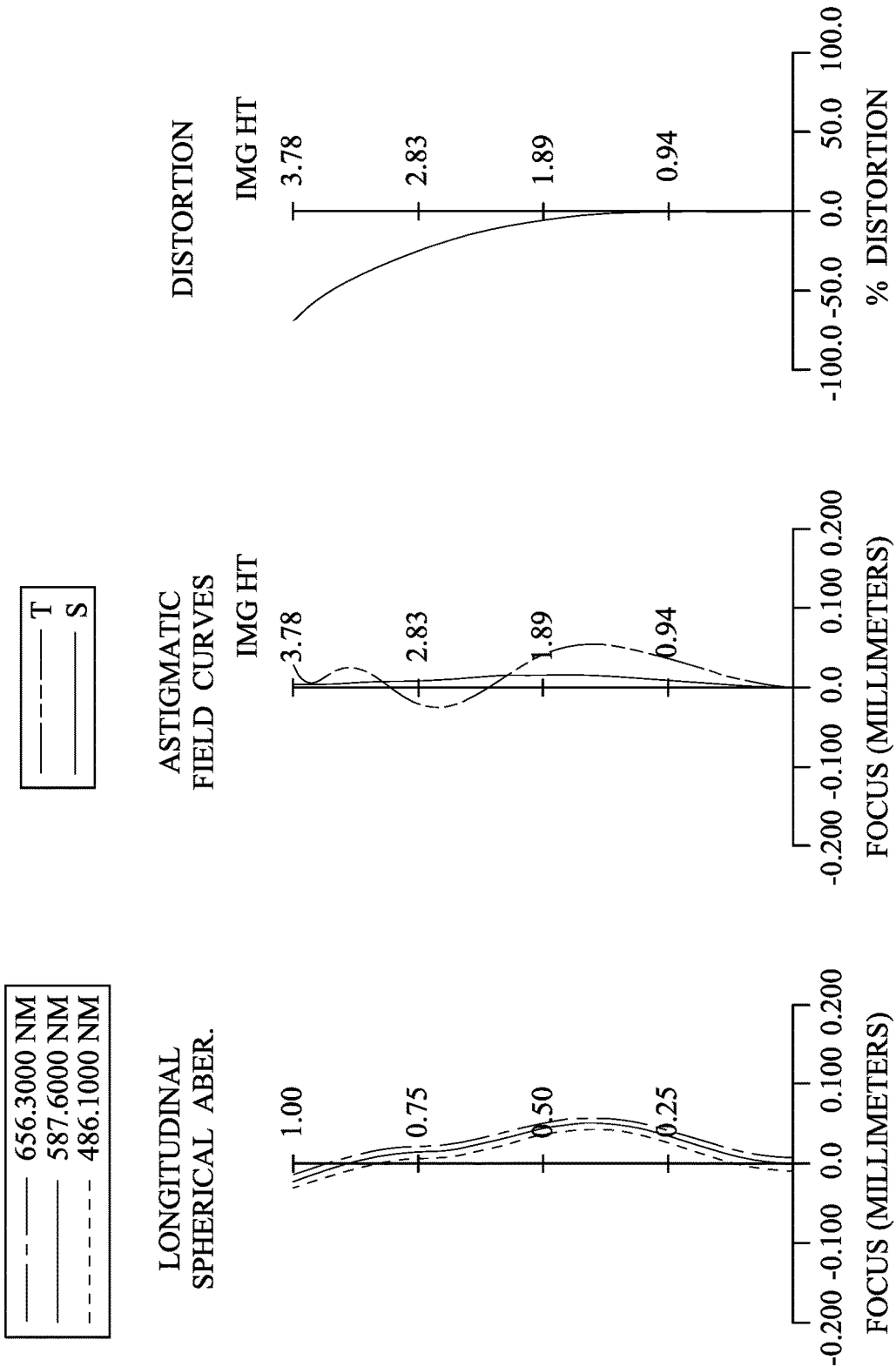

FIG. 8

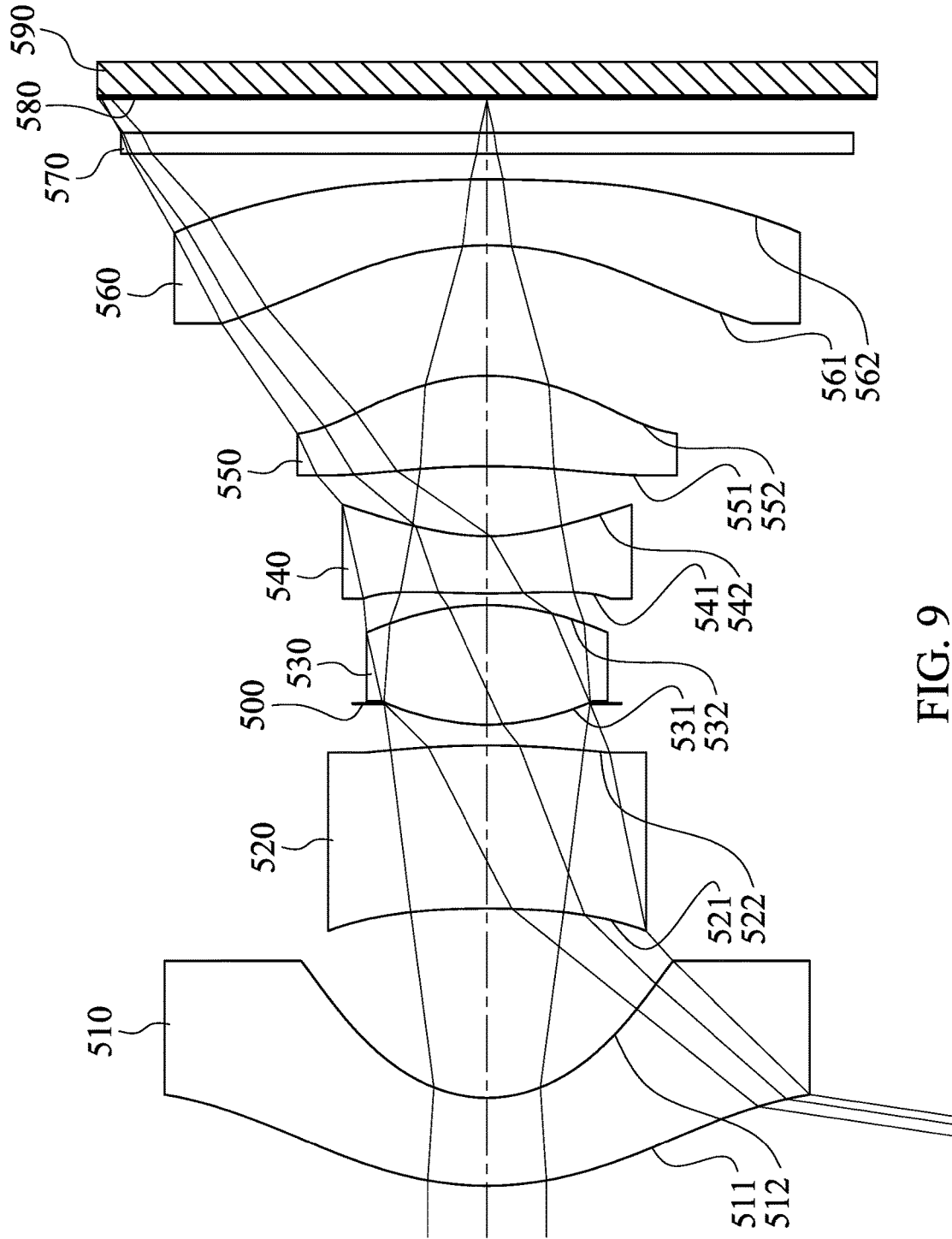

FIG. 9

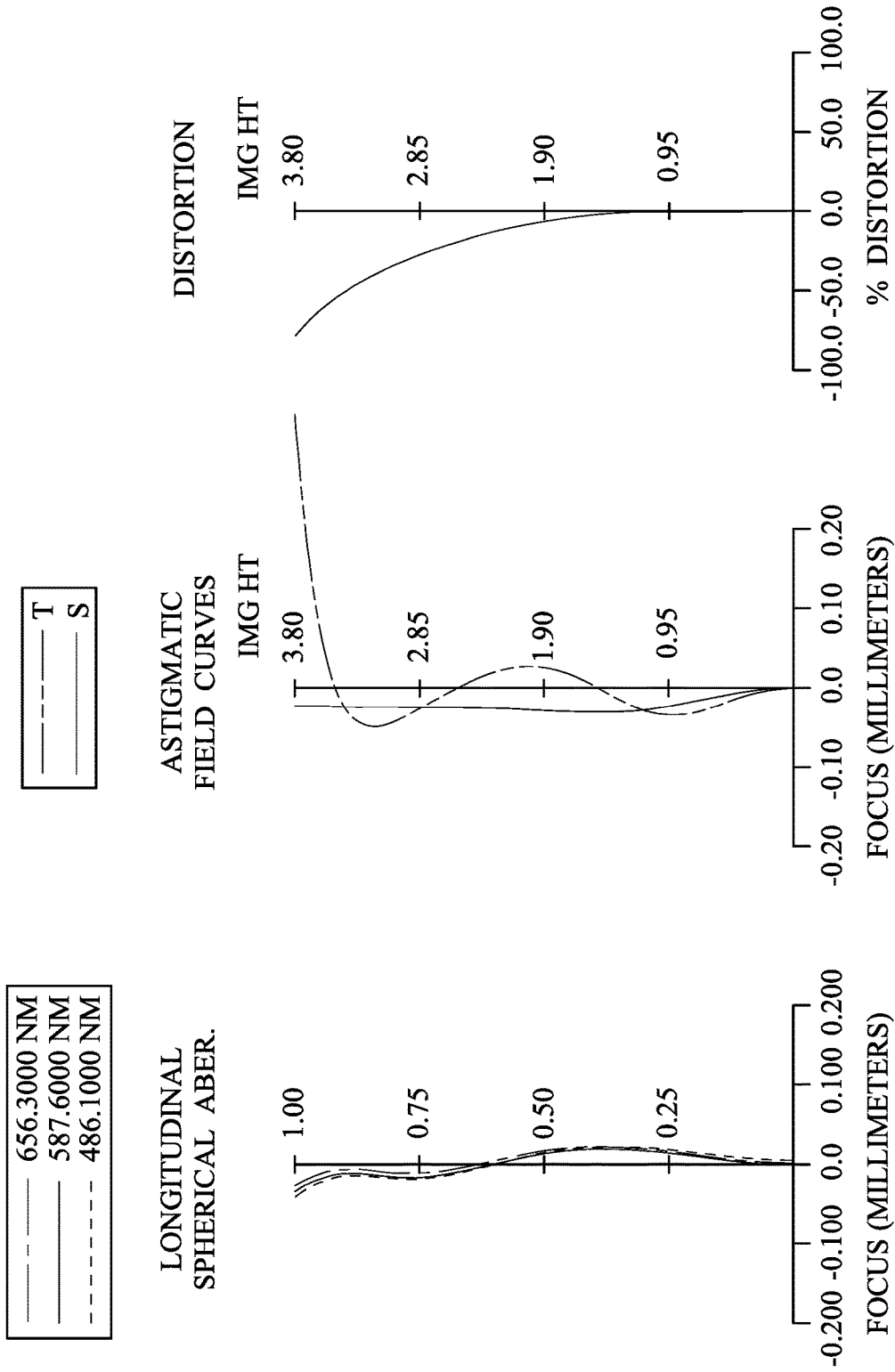

FIG. 10

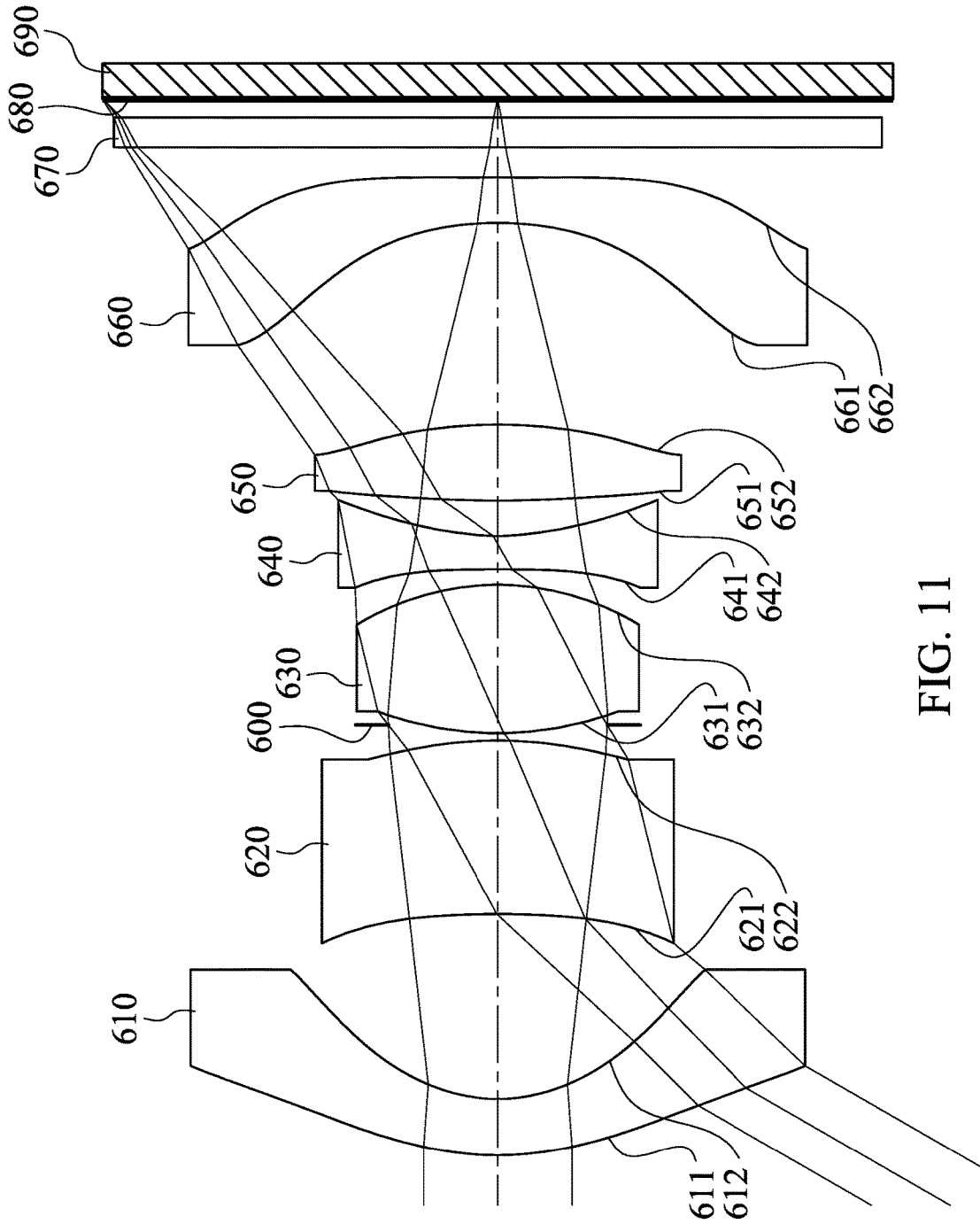

FIG. 11

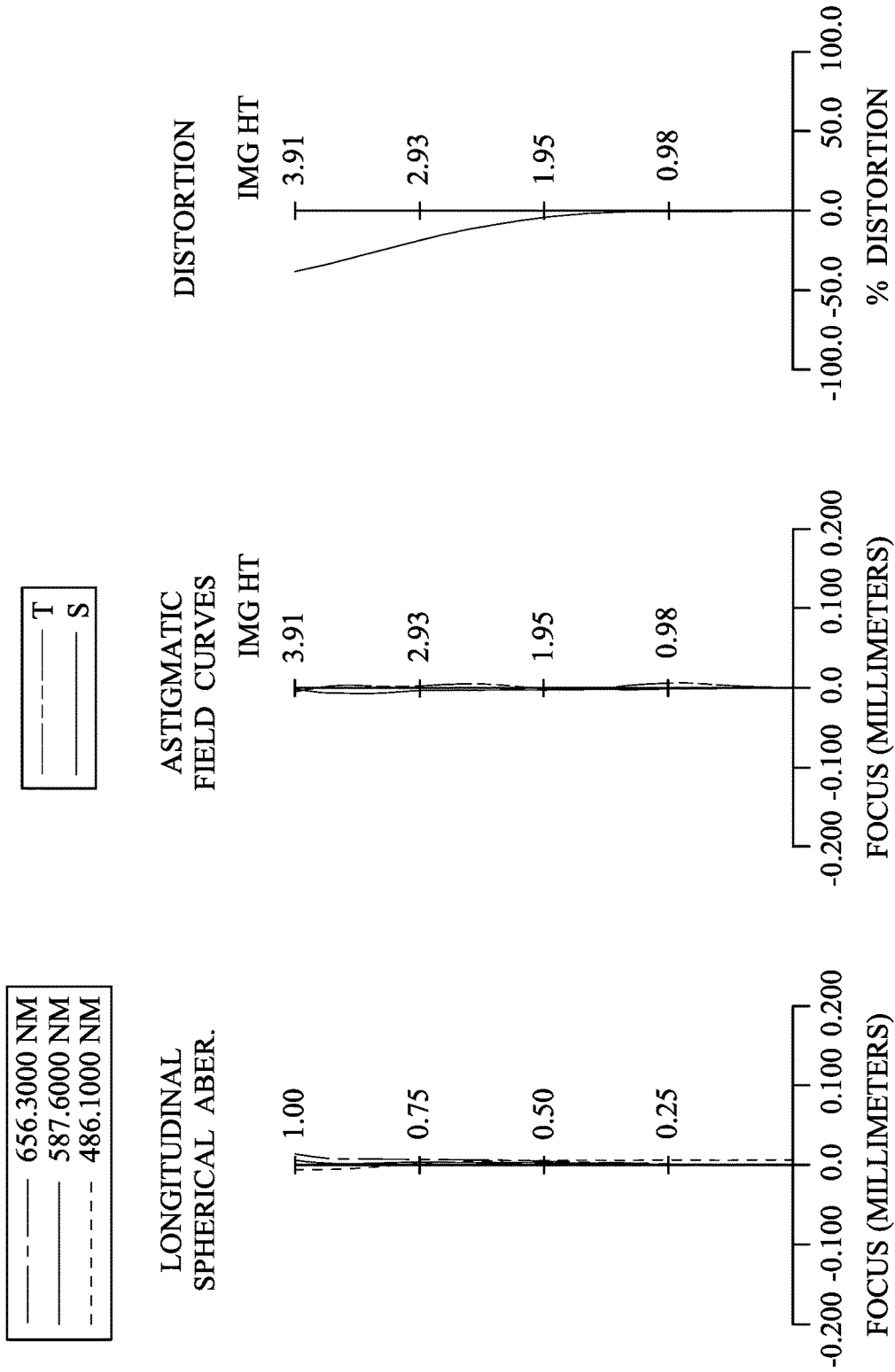

FIG. 12

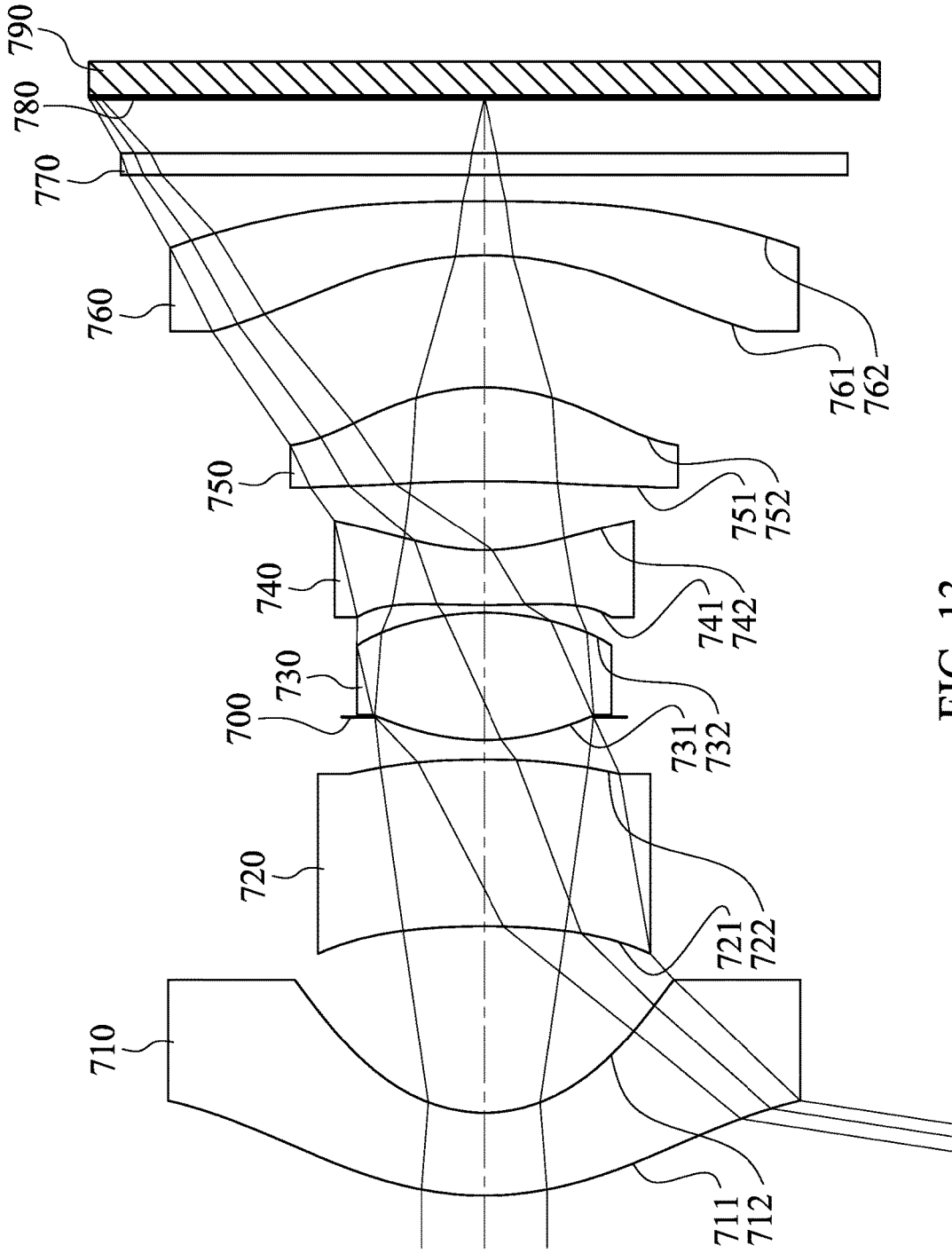

FIG. 13

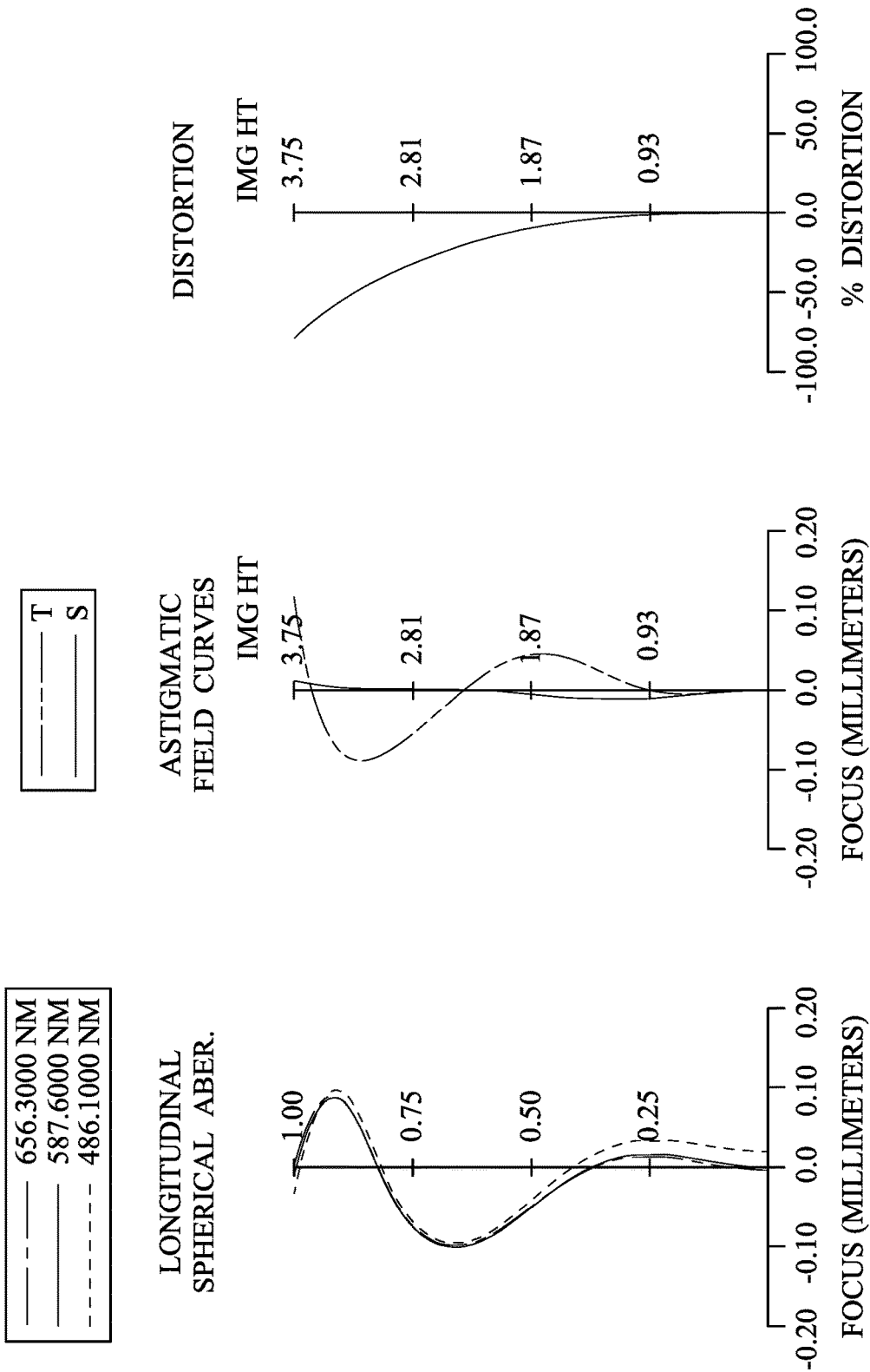

FIG. 14

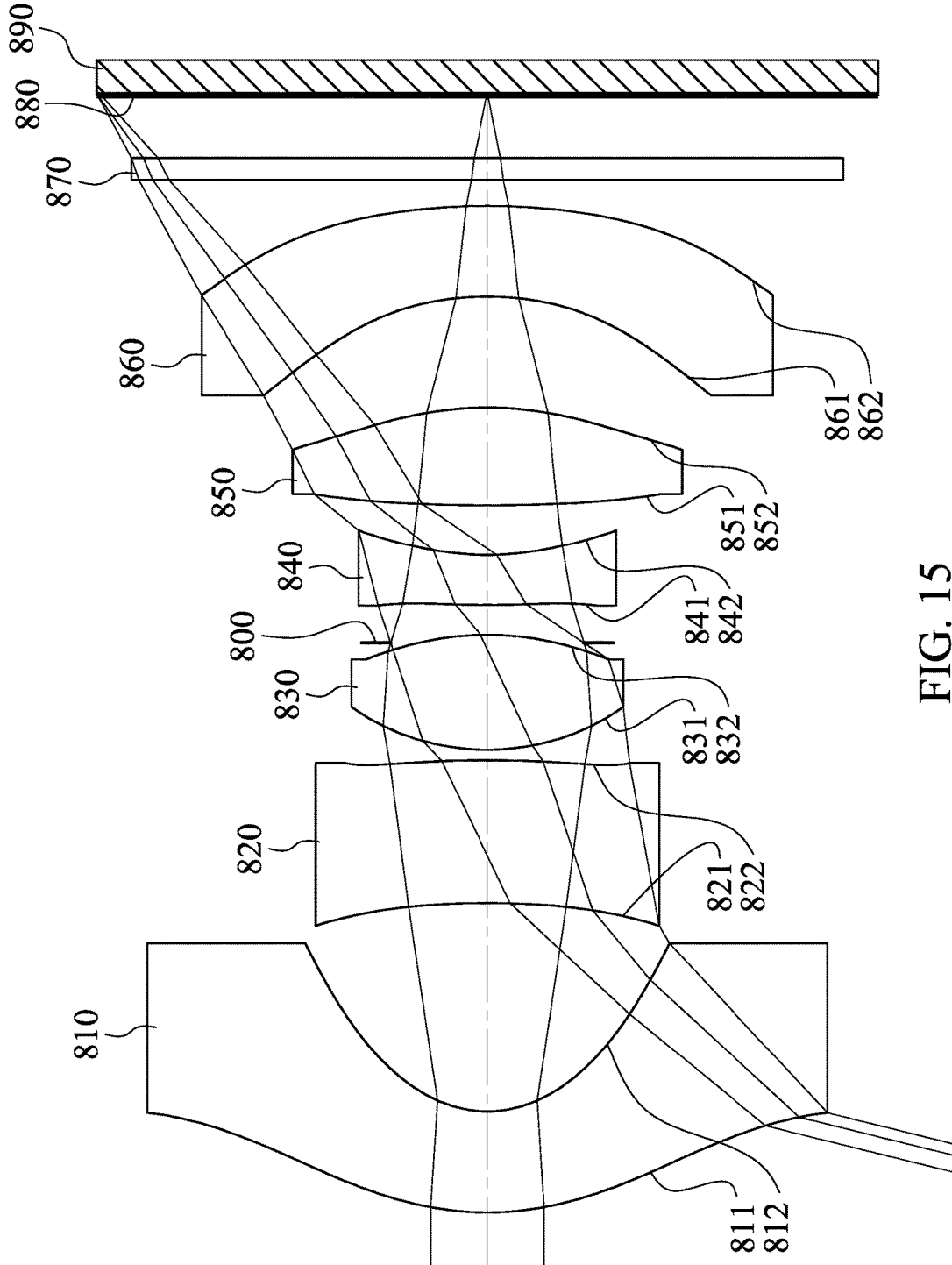

FIG. 15

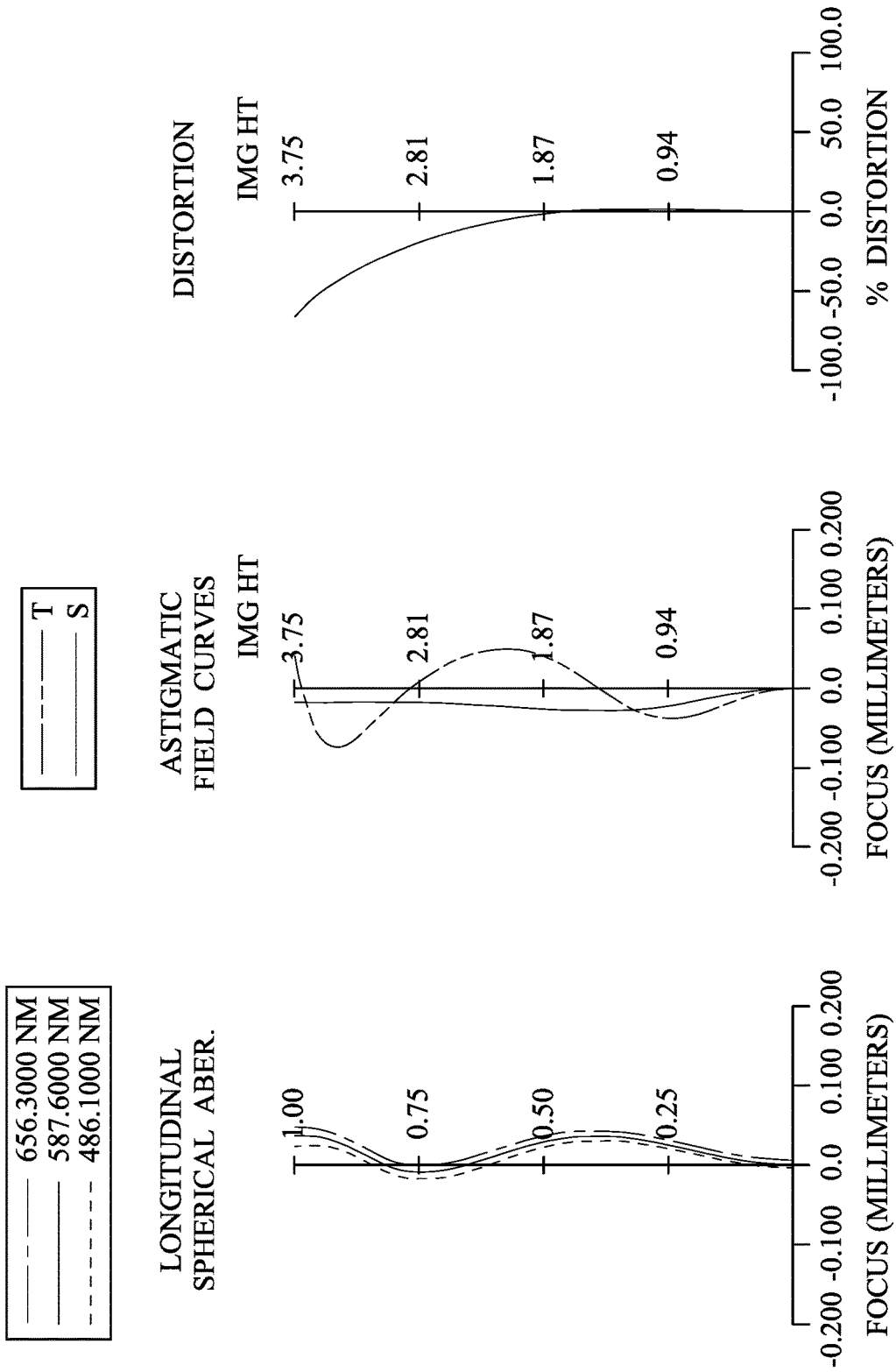

FIG. 16

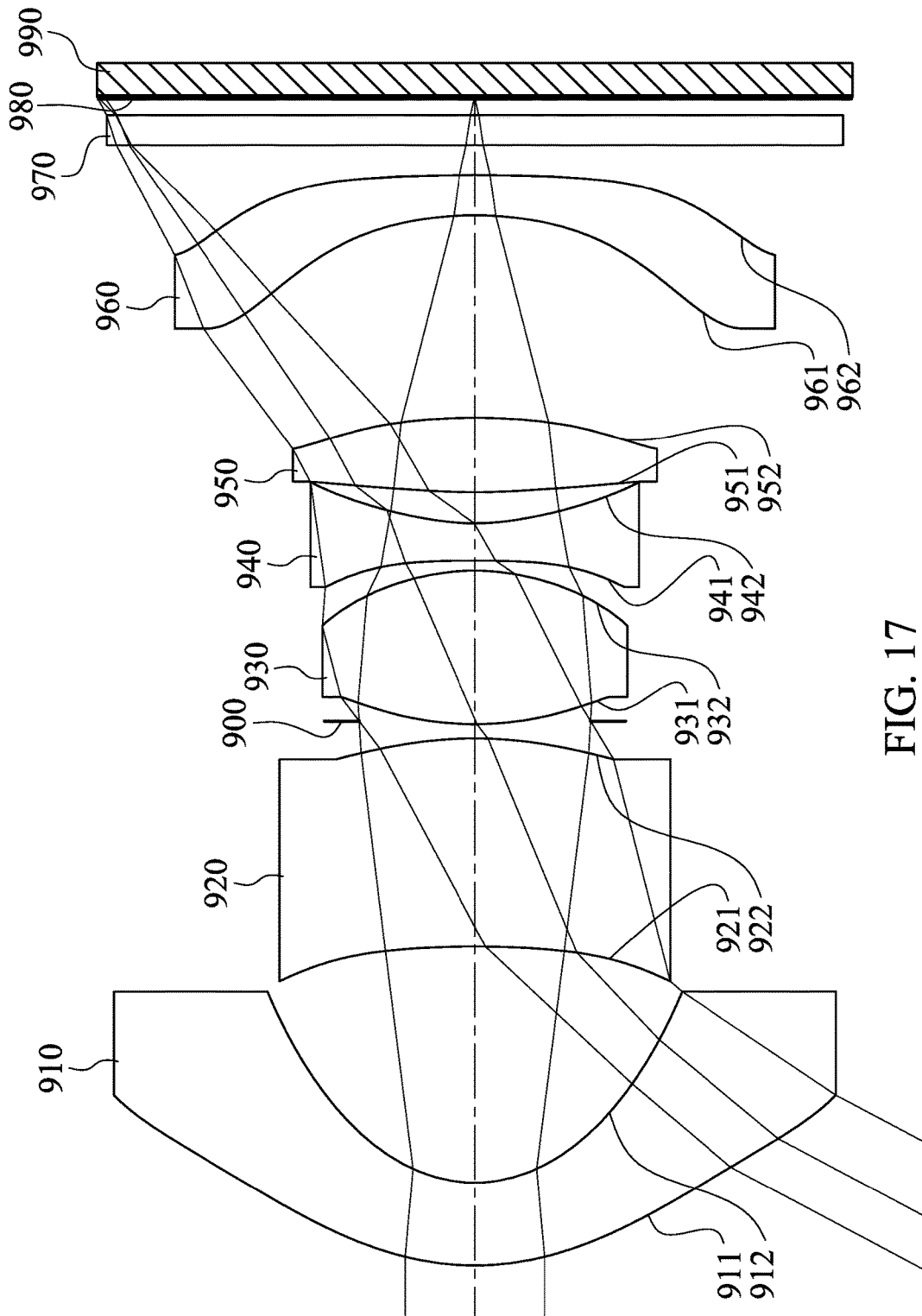

FIG. 17

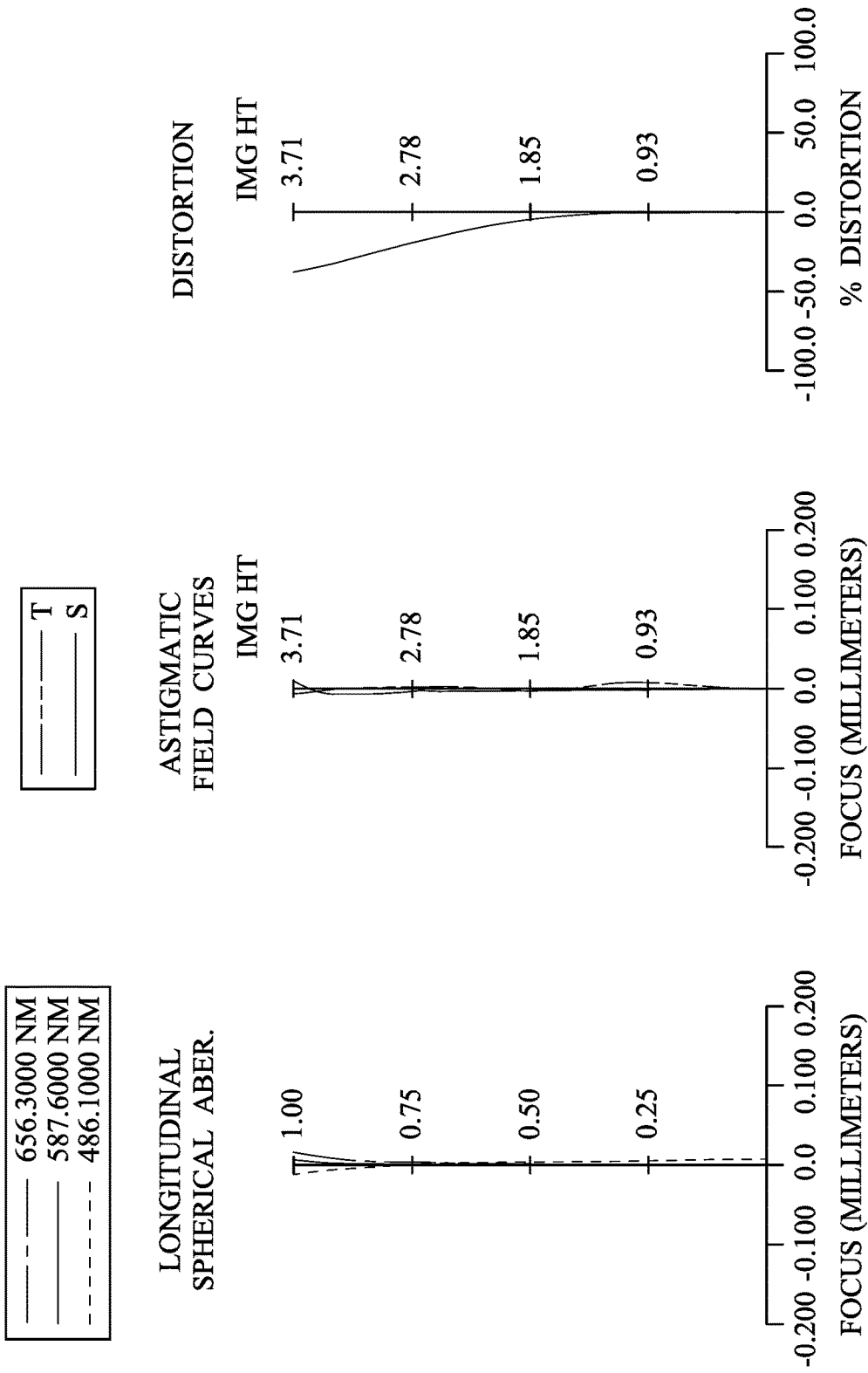

FIG. 18

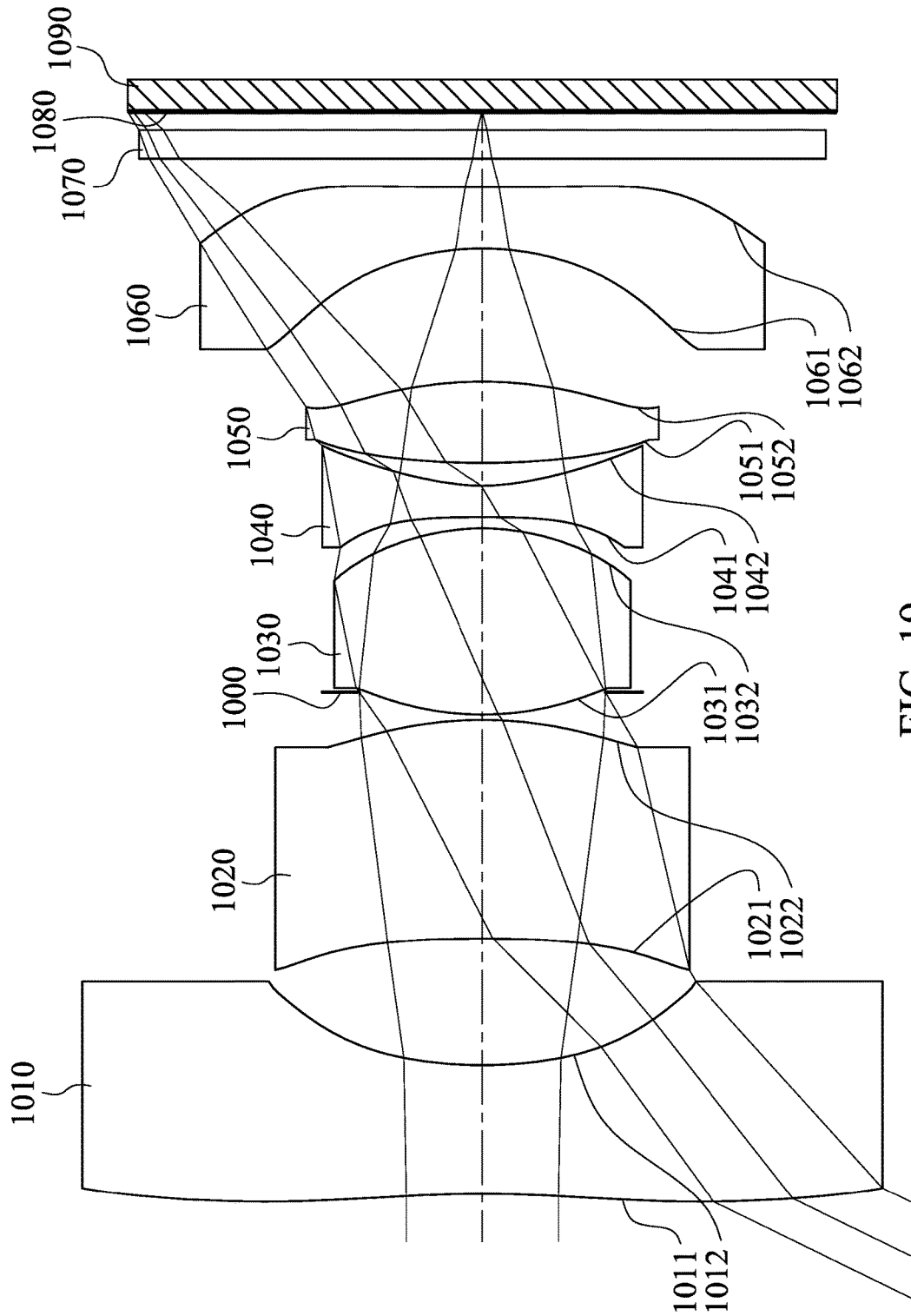

FIG. 19

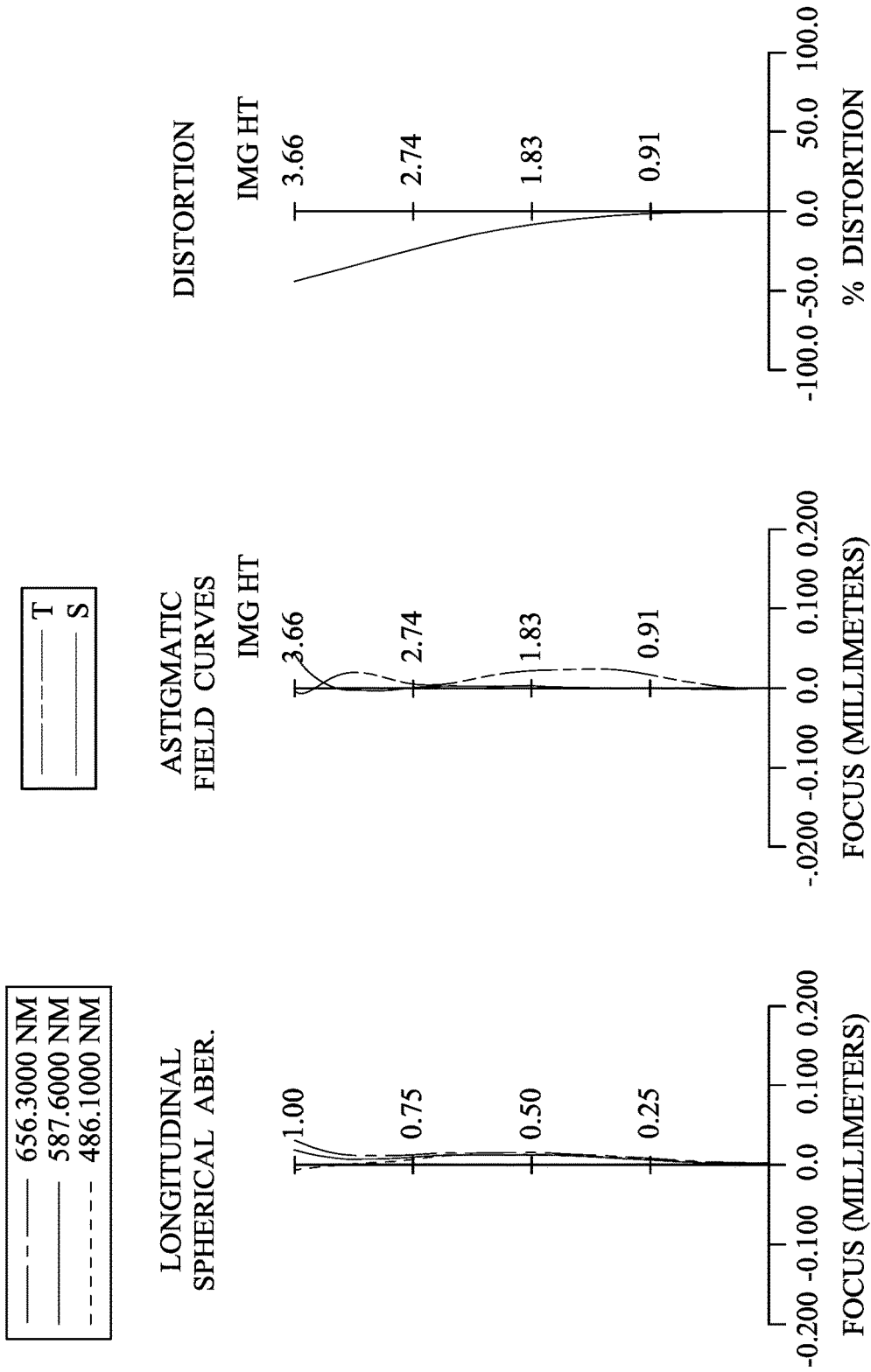

FIG. 20

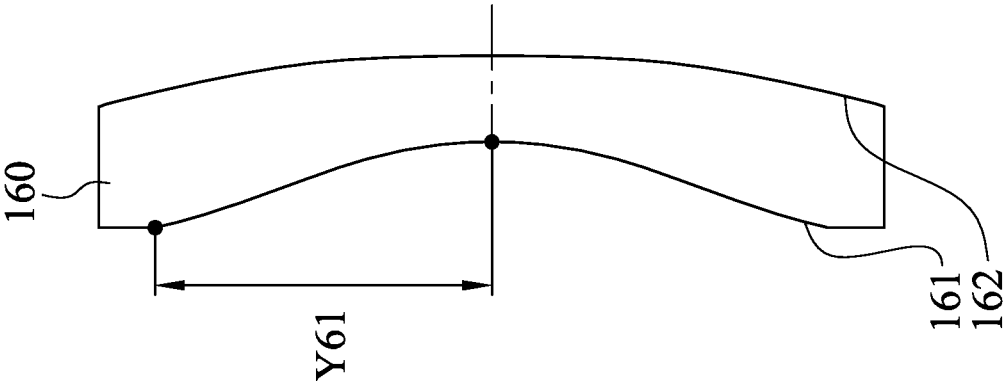

FIG. 21

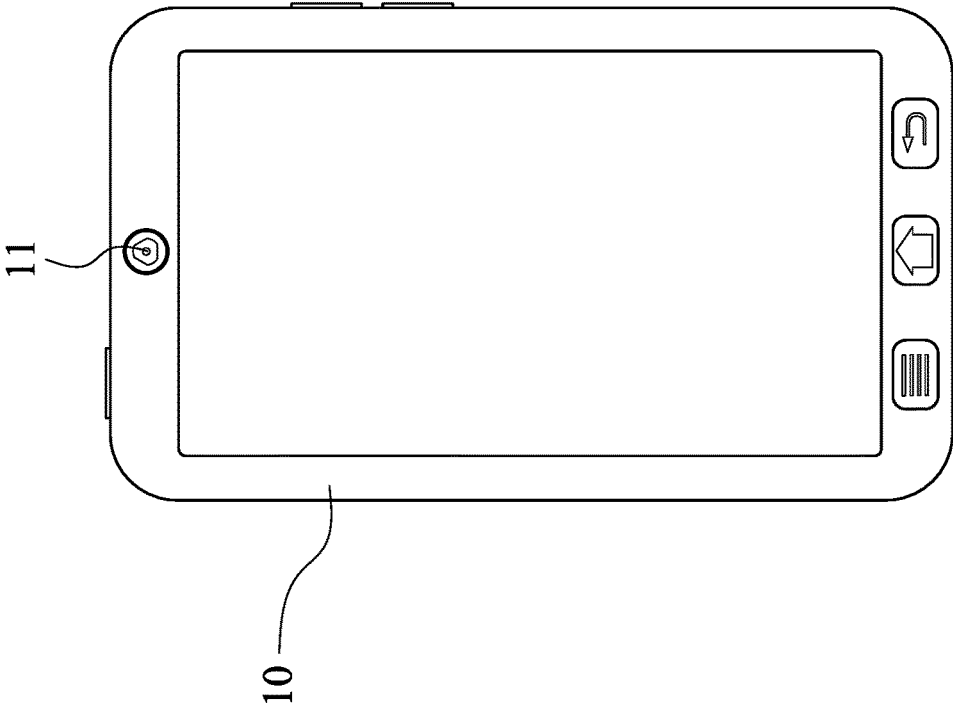

FIG. 22

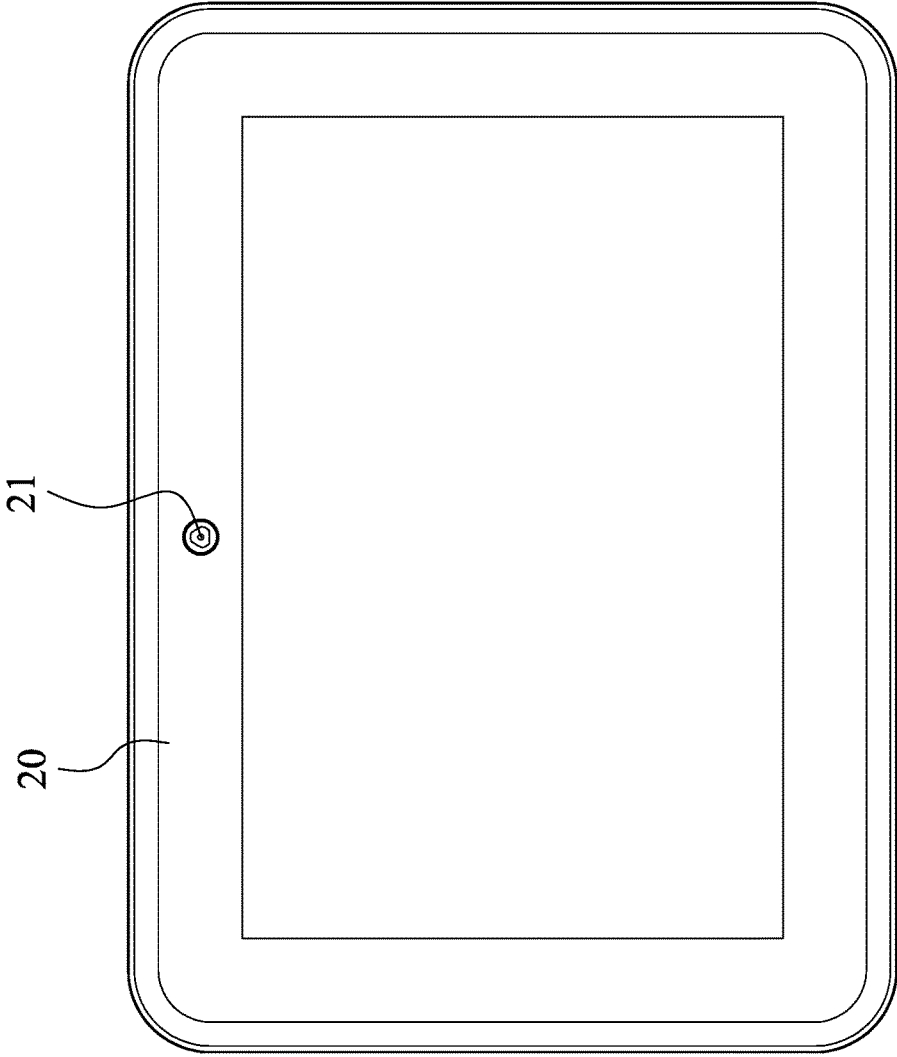

FIG. 23

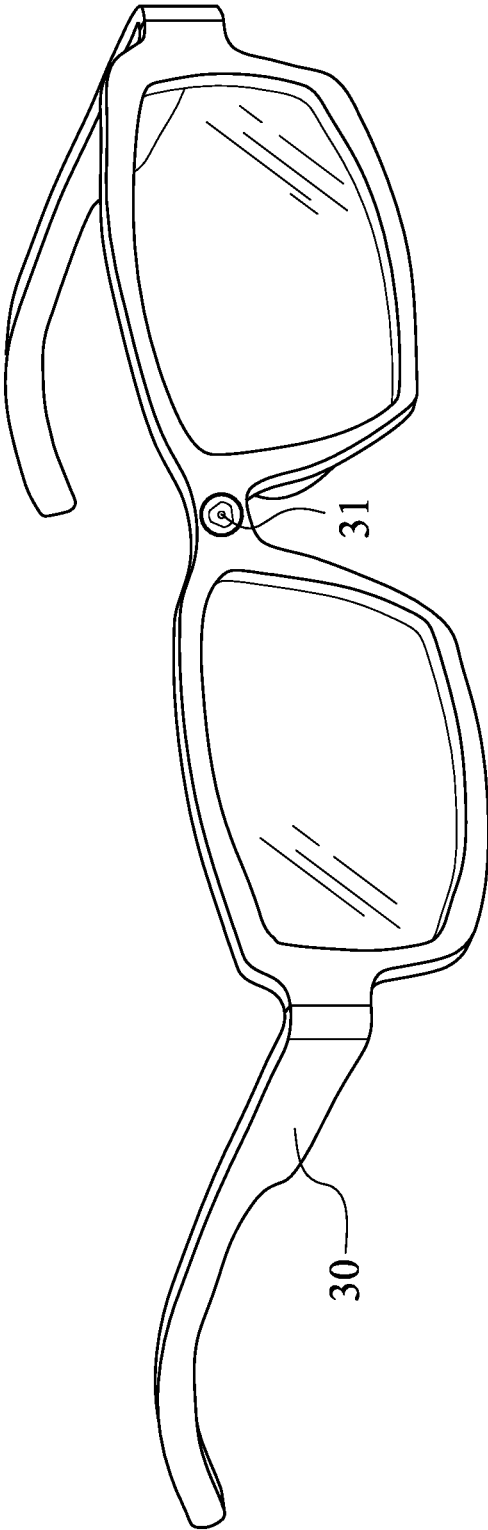

FIG. 24

**PHOTOGRAPHING OPTICAL LENS
SYSTEM, IMAGE CAPTURING APPARATUS
AND ELECTRONIC DEVICE**

RELATED APPLICATIONS

This application claims priority to Taiwan Application Serial Number 105117751, filed Jun. 4, 2016, which is herein incorporated by reference.

BACKGROUND

Technical Field

The present disclosure relates to a photographing optical lens system and an image capturing apparatus. More particularly, the present disclosure relates to a compact photographing optical lens system and an image capturing apparatus applicable to electronic devices.

Description of Related Art

With an increasing variety of applications of photographing modules, the standards for the specifications thereof are enhanced. In current market, the demands for miniaturization and high image quality are also increased. Furthermore, the field of view of the photographing modules are becoming larger so as to broaden the imaging range. However, limited by the surface shape and the material of the lens elements, the size of the conventional wide-angle lens assembly is bulky and cannot be reduced easily, which restricts the application scope thereof. Therefore, a lens assembly featured with a larger field of view, a compact size and a high image quality which can satisfy the specifications and demands of the future market is pursued. Thus, the lens assembly is favorable to be applied to vehicle cameras, all kinds of smart electronics, security monitoring devices, sports photography equipment, portable electronic devices, aerial photography devices, and so on.

SUMMARY

According to one aspect of the present disclosure, a photographing optical lens system includes, in order from an object side to an image side, a first lens element, a second lens element, a third lens element, a fourth lens element, a fifth lens element and a sixth lens element. The first lens element has negative refractive power. The second lens element has an image-side surface being convex in a paraxial region thereof. The third lens element has positive refractive power. The fourth lens element has negative refractive power. The sixth lens element with negative refractive power has an object-side surface being concave in a paraxial region thereof and an image-side surface being planar or convex in a paraxial region thereof. The photographing optical lens system has a total of six lens elements. When a curvature radius of an object-side surface of the third lens element is R5, a curvature radius of an image-side surface of the third lens element is R6, a curvature radius of an object-side surface of the fourth lens element is R7, a curvature radius of the object-side surface of the sixth lens element is R11, and a curvature radius of the image-side surface of the sixth lens element is R12, the following conditions are satisfied:

$$-1.0 \leq (R11 - R12) / (R11 + R12) < 0;$$

$$-1.50 < (R5 + R6) / (R5 - R6) < 3.50; \text{ and}$$

$$|R6 / R7| < 0.85.$$

According to another aspect of the present disclosure, an image capturing apparatus includes the photographing optical lens system according to the aforementioned aspect and an image sensor, wherein the image sensor is disposed on an image surface of the photographing optical lens system.

According to yet another aspect of the present disclosure, an electronic device includes the image capturing apparatus according to the aforementioned aspect.

According to further another aspect of the present disclosure, a photographing optical lens system includes, in order from an object side to an image side, a first lens element, a second lens element, a third lens element, a fourth lens element, a fifth lens element and a sixth lens element. The first lens element has negative refractive power. The second lens element has an image-side surface being convex in a paraxial region thereof. The third lens element has positive refractive power. The fourth lens element has negative refractive power. The sixth lens element with negative refractive power has an object-side surface being concave in a paraxial region thereof and an image-side surface being planar or convex in a paraxial region thereof. The photographing optical lens system has a total of six lens elements. When a curvature radius of the object-side surface of the sixth lens element is R11, a curvature radius of the image-side surface of the sixth lens element is R12, an axial distance between the first lens element and the second lens element is T12, an axial distance between the fifth lens element and the sixth lens element is T56, a central thickness of the first lens element is CT1, and an axial distance between the image-side surface of the sixth lens element and an image surface is BL, the following conditions are satisfied:

$$-1.0 \leq (R11 - R12) / (R11 + R12) < 0;$$

$$0.90 < T12 / CT1 < 9.0; \text{ and}$$

$$0 < BL / T56 < 1.65.$$

According to yet further another aspect of the present disclosure, a photographing optical lens system includes, in order from an object side to an image side, a first lens element, a second lens element, a third lens element, a fourth lens element, a fifth lens element and a sixth lens element. The first lens element has negative refractive power. The second lens element has an object-side surface being concave in a paraxial region thereof and an image-side surface being convex in a paraxial region thereof. The fourth lens element has an image-side surface being concave in a paraxial region thereof. The sixth lens element with negative refractive power has an object-side surface being concave in a paraxial region thereof and an image-side surface being planar or convex in a paraxial region thereof. The photographing optical lens system has a total of six lens elements. When a curvature radius of the object-side surface of the sixth lens element is R11, and a curvature radius of the image-side surface of the sixth lens element is R12, the following condition is satisfied:

$$-1.0 \leq (R11 - R12) / (R11 + R12) < 0.$$

According to yet further another aspect of the present disclosure, an image capturing apparatus includes the photographing optical lens system according to the aforementioned aspect and an image sensor, wherein the image sensor is disposed on an image surface of the photographing optical lens system.

According to yet further another aspect of the present disclosure, an electronic device includes the image capturing apparatus according to the aforementioned aspect.

BRIEF DESCRIPTION OF THE DRAWINGS

The present disclosure can be more fully understood by reading the following detailed description of the embodiment, with reference made to the accompanying drawings as follows:

FIG. 1 is a schematic view of an image capturing apparatus according to the 1st embodiment of the present disclosure;

FIG. 2 shows spherical aberration curves, astigmatic field curves and a distortion curve of the image capturing apparatus according to the 1st embodiment;

FIG. 3 is a schematic view of an image capturing apparatus according to the 2nd embodiment of the present disclosure;

FIG. 4 shows spherical aberration curves, astigmatic field curves and a distortion curve of the image capturing apparatus according to the 2nd embodiment;

FIG. 5 is a schematic view of an image capturing apparatus according to the 3rd embodiment of the present disclosure;

FIG. 6 shows spherical aberration curves, astigmatic field curves and a distortion curve of the image capturing apparatus according to the 3rd embodiment;

FIG. 7 is a schematic view of an image capturing apparatus according to the 4th embodiment of the present disclosure;

FIG. 8 shows spherical aberration curves, astigmatic field curves and a distortion curve of the image capturing apparatus according to the 4th embodiment;

FIG. 9 is a schematic view of an image capturing apparatus according to the 5th embodiment of the present disclosure;

FIG. 10 shows spherical aberration curves, astigmatic field curves and a distortion curve of the image capturing apparatus according to the 5th embodiment;

FIG. 11 is a schematic view of an image capturing apparatus according to the 6th embodiment of the present disclosure;

FIG. 12 shows spherical aberration curves, astigmatic field curves and a distortion curve of the image capturing apparatus according to the 6th embodiment;

FIG. 13 is a schematic view of an image capturing apparatus according to the 7th embodiment of the present disclosure;

FIG. 14 shows spherical aberration curves, astigmatic field curves and a distortion curve of the image capturing apparatus according to the 7th embodiment;

FIG. 15 is a schematic view of an image capturing apparatus according to the 8th embodiment of the present disclosure;

FIG. 16 shows spherical aberration curves, astigmatic field curves and a distortion curve of the image capturing apparatus according to the 8th embodiment;

FIG. 17 is a schematic view of an image capturing apparatus according to the 9th embodiment of the present disclosure;

FIG. 18 shows spherical aberration curves, astigmatic field curves and a distortion curve of the image capturing apparatus according to the 9th embodiment;

FIG. 19 is a schematic view of an image capturing apparatus according to the 10th embodiment of the present disclosure;

FIG. 20 shows spherical aberration curves, astigmatic field curves and a distortion curve of the image capturing apparatus according to the 10th embodiment;

FIG. 21 shows a schematic view of the parameter Y61 of a sixth lens element according to the 1st embodiment;

FIG. 22 is a schematic view of an electronic device according to the 11th embodiment of the present disclosure;

FIG. 23 is a schematic view of an electronic device according to the 12th embodiment of the present disclosure; and

FIG. 24 is a schematic view of an electronic device according to the 13th embodiment of the present disclosure.

DETAILED DESCRIPTION

A photographing optical lens system includes, in order from an object side to an image side, a first lens element, a second lens element, a third lens element, a fourth lens element, a fifth lens element and a sixth lens element, wherein the photographing optical lens system has a total of six lens elements.

There is an air space between every two lens elements of the first lens element, the second lens element, the third lens element, the fourth lens element, the fifth lens element and the sixth lens element that are adjacent to each other. That is, each of the first through sixth lens elements is a single and non-cemented lens element, any two lens elements adjacent to each other are not cemented, and there is a space between the two lens elements. In other words, of the first lens element, the second lens element, the third lens element, the fourth lens element, the fifth lens element and the sixth lens element of the photographing optical lens system, there is a space in a paraxial region between every two lens elements that are adjacent to each other. Moreover, the manufacturing process of the cemented lenses is more complex than the non-cemented lenses. In particular, a second surface of one lens element and a first surface of the following lens element need to have accurate curvature to ensure these two lens elements will be highly cemented. However, during the cementing process, those two lens elements might not be highly cemented due to displacement and it is thereby not favorable for the image quality of the photographing optical lens system. Therefore, according to the photographing optical lens system of the present disclosure, an air space in a paraxial region between every two of the first lens element, the second lens element, the third lens element, the fourth lens element, the fifth lens element and the sixth lens element that are adjacent to each other avoids the problem generated by the cemented lens elements.

The first lens element with negative refractive power has an object-side surface being convex in a paraxial region thereof and can have an image-side surface being concave in a paraxial region thereof. Therefore, it is favorable to form a retro-focus structure, which enables the light rays of large field of view to enter into the photographing optical lens system.

The second lens element can have an object-side surface being concave in a paraxial region thereof and has an image-side surface being convex in a paraxial region thereof. Therefore, aberrations generated from the large field of view can be balanced, and the insufficient brightness of the peripheral image can be improved.

The third lens element can have positive refractive power. Therefore, the main light converging ability of the photographing optical lens system can be provided, which is favorable to reduce the total track length thereof.

The fourth lens element can have negative refractive power and has an image-side surface being concave in a paraxial region thereof. Therefore, the negative refractive power of the fourth lens element can be enhanced so as to

balance the positive refractive power of the third lens element, and the chromatic aberration of the photographing optical lens system can be corrected.

The sixth lens element has negative refractive power. Therefore, the principal point of the photographing optical lens system can be shifted toward the object side so as to shorten the back focal length, and the total track length thereof can be accordingly controlled. The sixth lens element has an object-side surface being concave in a paraxial region thereof and an image-side surface being planar or convex in a paraxial region thereof. Therefore, aberrations of the image side of the photographing optical lens system can be corrected, and the light sensing area thereof can be increased so as to enhance the image brightness. Furthermore, at least one of the object-side surface and the image-side surface of the sixth lens element includes at least one inflection point. Therefore, aberrations of the off-axis field caused by the large field of view can be corrected.

When a curvature radius of the object-side surface of the sixth lens element is R11, and a curvature radius of the image-side surface of the sixth lens element is R12, the following condition is satisfied: $-1.0 \leq (R11 - R12) / (R11 + R12) < 0$. Therefore, the shape of the sixth lens element can be adjusted so as to enhance the symmetry of the photographing optical lens system and to afford the photographing optical lens system a sufficient light sensing area. Accordingly, aberrations can be further corrected, and a better image quality can be obtained.

When a curvature radius of an object-side surface of the third lens element is R5, and a curvature radius of the image-side surface of the third lens element is R6, the following condition can be satisfied: $-1.50 < (R5 + R6) / (R5 - R6) < 3.50$. Therefore, the shape of the third lens element can be effectively controlled, which is favorable for molding the third lens element and correcting the spherical aberration of the photographing optical lens system. Preferably, the following condition can be satisfied: $-1.0 < (R5 + R6) / (R5 - R6) < 1.0$. More preferably, the following condition can be satisfied: $-0.45 < (R5 + R6) / (R5 - R6) < 0.45$.

When the curvature radius of the image-side surface of the third lens element is R6, and a curvature radius of an object-side surface of the fourth lens element is R7, the following condition can be satisfied: $R6/R7 < 0.85$. Therefore, the curvature configuration of the third lens element and the fourth lens element can be adjusted, which is favorable for assembling the lens elements.

The photographing optical lens system can further include a stop, the stop can be an aperture stop, and the stop can be disposed between the second lens element and the third lens element. When an axial distance between the stop and the image-side surface of the sixth lens element is SD, and an axial distance between the object-side surface of the first lens element and the image-side surface of the sixth lens element is TD, the following condition can be satisfied: $0.40 < SD/TD < 0.60$. Therefore, the position of the stop is proper, which enables the light rays of large field of view to enter into the photographing optical lens system and can suppress the total track length thereof, so that the wide-angle property can be reinforced.

When a composite focal length of lens elements between an imaged object and the stop is ff, and a composite focal length of lens elements between the stop and an image surface is fr, the following condition can be satisfied: $|fr/ff| < 0.67$. Therefore, the refractive power configuration of the object side and the image side of the photographing optical lens system can be adjusted, which provides the photographing optical lens system with the wide-angle characteristic.

When an axial distance between the image-side surface of the sixth lens element and the image surface is BL, and an axial distance between the object-side surface of the first lens element and the image surface is TL, the following condition can be satisfied: $0 < BL/TL < 0.20$. Therefore, the back focal length of the photographing optical lens system can be controlled, which is favorable to correct Petzval field curvature and can further control the total track length thereof. Preferably, the following condition can be satisfied: $0 < BL/TL < 0.15$.

When a focal length of the photographing optical lens system is f, and a central thickness of the second lens element is CT2, the following condition can be satisfied: $0 < f/CT2 < 4.0$. Therefore, the wide-angle with short focal length property can be reinforced, which is favorable for reducing the axial chromatic aberration. Furthermore, the central thickness of the second lens element can be properly adjusted, so that the progress of the light rays of large field of view of the first lens element can be moderated. Preferably, the following condition can be satisfied: $0 < f/CT2 < 3.0$.

When an Abbe number of the second lens element is V2, the following condition can be satisfied: $V2 < 25.0$. Therefore, the chromatic aberration of the photographing optical lens system can be corrected, which enables the imaging points of light rays in different wavelength range to be more concentrated. Furthermore, the progress of the light rays of large field of view of the first lens element can be moderated.

When a refractive power of the first lens element is P1, a refractive power of the second lens element is P2, a refractive power of the third lens element is P3, a refractive power of the fourth lens element is P4, a refractive power of the fifth lens element is P5, and a refractive power of the sixth lens element is P6, the following conditions can be satisfied: $|P3| > |P1|$; $|P3| > |P2|$; $|P3| > |P5|$; $|P3| > |P6|$; $|P4| > |P1|$; $|P4| > |P2|$; $|P4| > |P5|$; and $|P4| > |P6|$. Therefore, the refractive power configuration of the lens elements can be effectively adjusted, so that the ability for correcting aberrations of the object side and the image side of the photographing optical lens system can be reinforced, and the photosensitivity thereof can be reduced. Specifically, P1 is a ratio of the focal length of the photographing optical lens system and a focal length of the first lens element, P2 is a ratio of the focal length of the photographing optical lens system and a focal length of the second lens element, P3 is a ratio of the focal length of the photographing optical lens system and a focal length of the third lens element, P4 is a ratio of the focal length of the photographing optical lens system and a focal length of the fourth lens element, P5 is a ratio of the focal length of the photographing optical lens system and a focal length of the fifth lens element, and P6 is a ratio of the focal length of the photographing optical lens system and a focal length of the sixth lens element.

When an axial distance between the first lens element and the second lens element is T12, an axial distance between the second lens element and the third lens element is T23, an axial distance between the third lens element and the fourth lens element is T34, an axial distance between the fourth lens element and the fifth lens element is T45, and an axial distance between the fifth lens element and the sixth lens element is T56, the following conditions can be satisfied: $T12 > T23$; $T12 > T34$; $T12 > T45$; $T56 > T23$; $T56 > T34$; and $T56 > T45$. Therefore, the axial distance between every two lens element adjacent to each other can be adjusted, which is favorable to enhance the symmetry of the photographing optical lens system and improve the image quality.

When the curvature radius of the object-side surface of the sixth lens element is R11, a vertical distance between a

maximum effective diameter position on the object-side surface of the sixth lens element and an optical axis is Y61, the following condition can be satisfied: $-1.85 < R11/Y61 < -0.50$. Therefore, the surface curvature and the maximum effective diameter position of the object-side surface of the sixth lens element can be properly adjusted, which can broaden the imaging range and is favorable for correcting aberrations of the off-axis field. Preferably, the following condition can be satisfied: $-1.50 < R11/Y61 < -0.50$.

When the axial distance between the first lens element and the second lens element is T12, and a central thickness of the first lens element is CT1, the following condition can be satisfied: $0.90 < T12/CT1 < 9.0$. Therefore, the axial distance between the first lens element and the second lens element is sufficient, which is favorable for assembling the photographing optical lens system.

When the axial distance between the image-side surface of the sixth lens element and the image surface is BL, and the axial distance between the fifth lens element and the sixth lens element is T56, the following condition can be satisfied: $0 < BL/T56 < 1.65$. Therefore, the axial distance between the fifth lens element and the sixth lens element can be adjusted so as to provide the image side of the photographing optical lens system a sufficient space for integrating light rays, and the back focal length thereof can be further reduced.

When a curvature radius of the image-side surface of the first lens element is R2, and the curvature radius of the object-side surface of the sixth lens element is R11, the following condition can be satisfied: $-1.0 < (R2+R11)/(R2-R11) < 1.0$. Therefore, the curvature configuration of lens elements of the object side and the image side of the photographing optical lens system can be properly adjusted, which can enhance the symmetry of the retro-focus structure, reduce the photosensitivity of the photographing optical lens system and improve the image quality. Preferably, the following condition can be satisfied: $-0.60 < (R2+R11)/(R2-R11) < 0.50$.

When an Abbe number of the fourth lens element is V4, the following condition can be satisfied: $V4 < 25.0$. Therefore, the chromatic aberration of the photographing optical lens system can be effectively corrected, so that the overlap of images can be avoided.

When a half of a maximum field of view of the photographing optical lens system is HFOV, the following condition can be satisfied: $1/\tan(HFOV) < 0.80$. Therefore, the field of view can be effectively increased, and the application scope of the photographing optical lens system can be broadened.

According to the photographing optical lens system of the present disclosure, the lens elements thereof can be made of a plastic or a glass material. When the lens elements are made of a plastic material, the manufacturing cost can be effectively reduced. When the lens elements are made of a glass material, the distribution of the refractive powers of the photographing optical lens system may be more flexible to design. Furthermore, surfaces of each lens element can be arranged to be aspheric (ASP), since the aspheric surface of the lens element is easy to form a shape other than spherical surface so as to have more controllable variables for eliminating aberrations thereof, and to further decrease the required number of the lens elements. Therefore, the total track length of the photographing optical lens system can also be reduced.

According to the photographing optical lens system of the present disclosure, each of an object-side surface and an image-side surface has a paraxial region and an off-axis

region. The paraxial region refers to the region of the surface where light rays travel close to the optical axis, and the off-axis region refers to the region of the surface away from the paraxial region. Particularly, if not stated otherwise, when the lens element has a convex surface, it indicates that the surface is convex in the paraxial region thereof; when the lens element has a concave surface, it indicates that the surface is concave in the paraxial region thereof. According to the photographing optical lens system of the present disclosure, the positive refractive power or the negative refractive power of a lens element or the focal length of the lens element, that is, may refer to the refractive power or the focal length in the paraxial region of the lens element.

According to the photographing optical lens system of the present disclosure, the image surface of the photographing optical lens system, based on the corresponding image sensor, can be flat or curved. In particular, the image surface can be a curved surface being concave facing towards the object side.

According to the photographing optical lens system of the present disclosure, the photographing optical lens system can include at least one stop, such as an aperture stop, a glare stop or a field stop. Said glare stop or said field stop is for eliminating the stray light and thereby improving the image resolution thereof.

According to the photographing optical lens system of the present disclosure, an aperture stop can be configured as a front stop or a middle stop. The front stop disposed between an imaged object and the first lens element can provide a longer distance from an exit pupil of the photographing optical lens system to the image surface and thereby improves the image-sensing efficiency of an image sensor. A middle stop disposed between the first lens element and the image surface is favorable for enlarging the field of view of the photographing optical lens system and thereby provides a wider field of view for the same.

According to the photographing optical lens system of the present disclosure, the photographing optical lens system can be optionally applied to moving focus optical systems, and is featured with good ability for correcting aberrations and high image quality. The photographing optical lens system of the present disclosure also can be applied to 3D (three-dimensional) image capturing applications, in products such as digital cameras, mobile devices, digital tablets, smart TV, surveillance devices, game consoles with motion sensing function, vehicle cameras such as driving recording systems and rear view camera systems, aerial photography devices, sports photography equipment, all kinds of smart electronics and wearable devices.

According to the present disclosure, an image capturing apparatus is provided. The image capturing apparatus includes the aforementioned photographing optical lens system and an image sensor, wherein the image sensor is disposed at the image side of the aforementioned photographing optical lens system, that is, the image sensor can be disposed on or near the image surface of the aforementioned photographing optical lens system. In the photographing optical lens system, with the configuration of the lens elements, the photographing optical lens system is featured with a larger field of view, a compact size and high image quality. Preferably, the image capturing apparatus can further include a barrel member, a holding member or a combination thereof.

According to the present disclosure, an electronic device is provided. The electronic device includes the aforementioned image capturing apparatus. Therefore, the electronic device is featured with a larger field of view, a compact size

and high image quality. Preferably, the electronic device can further include but not limited to a control unit, a display, a storage unit, a random access memory unit (RAM), a read only memory unit (ROM) or a combination thereof.

According to the above description of the present disclosure, the following 1st-13th specific embodiments are provided for further explanation.

1st Embodiment

FIG. 1 is a schematic view of an image capturing apparatus according to the 1st embodiment of the present disclosure. FIG. 2 shows spherical aberration curves, astigmatic field curves and a distortion curve of the image capturing apparatus according to the 1st embodiment. In FIG. 1, the image capturing apparatus includes a photographing optical lens system (its reference numeral is omitted) and an image sensor 190. The photographing optical lens system includes, in order from an object side to an image side, a first lens element 110, a second lens element 120, an aperture stop 100, a third lens element 130, a fourth lens element 140, a fifth lens element 150, a sixth lens element 160, an IR-cut filter 170 and an image surface 180, wherein the image sensor 190 is disposed on the image surface 180 of the photographing optical lens system. The photographing optical lens system has a total of six lens elements (110-160), and there is an air space between every two lens elements of the first lens element 110, the second lens element 120, the third lens element 130, the fourth lens element 140, the fifth lens element 150 and the sixth lens element 160 that are adjacent to each other.

The first lens element 110 with negative refractive power has an object-side surface 111 being convex in a paraxial region thereof and an image-side surface 112 being concave in a paraxial region thereof. The first lens element 110 is made of a plastic material, and has the object-side surface 111 and the image-side surface 112 being both aspheric.

The second lens element 120 with positive refractive power has an object-side surface 121 being concave in a paraxial region thereof and an image-side surface 122 being convex in a paraxial region thereof. The second lens element 120 is made of a plastic material, and has the object-side surface 121 and the image-side surface 122 being both aspheric.

The third lens element 130 with positive refractive power has an object-side surface 131 being convex in a paraxial region thereof and an image-side surface 132 being convex in a paraxial region thereof. The third lens element 130 is made of a plastic material, and has the object-side surface 131 and the image-side surface 132 being both aspheric.

The fourth lens element 140 with negative refractive power has an object-side surface 141 being concave in a paraxial region thereof and an image-side surface 142 being concave in a paraxial region thereof. The fourth lens element 140 is made of a plastic material, and has the object-side surface 141 and the image-side surface 142 being both aspheric.

The fifth lens element 150 with positive refractive power has an object-side surface 151 being concave in a paraxial region thereof and an image-side surface 152 being convex in a paraxial region thereof. The fifth lens element 150 is made of a plastic material, and has the object-side surface 151 and the image-side surface 152 being both aspheric.

The sixth lens element 160 with negative refractive power has an object-side surface 161 being concave in a paraxial region thereof and an image-side surface 162 being convex in a paraxial region thereof. The sixth lens element 160 is

made of a plastic material, and has the object-side surface 161 and the image-side surface 162 being both aspheric. Furthermore, the object-side surface 161 and the image-side surface 162 of the sixth lens element 160 include at least one inflection point.

The IR-cut filter 170 is made of a glass material and located between the sixth lens element 160 and the image surface 180, and will not affect the focal length of the photographing optical lens system.

The equation of the aspheric surface profiles of the aforementioned lens elements of the 1st embodiment is expressed as follows:

$$X(Y) = (Y^2/R)/(1 + \sqrt{1 - (1+k) \times (Y/R)^2}) + \sum_i (Ai) \times (Y^i),$$

where,

X is the relative distance between a point on the aspheric surface spaced at a distance Y from an optical axis and the tangential plane at the aspheric surface vertex on the optical axis;

Y is the vertical distance from the point on the aspheric surface to the optical axis;

R is the curvature radius;

k is the conic coefficient; and

Ai is the i-th aspheric coefficient.

In the photographing optical lens system according to the 1st embodiment, when a focal length of the photographing optical lens system is f, an f-number of the photographing optical lens system is Fno, and half of a maximum field of view of the photographing optical lens system is HFOV, these parameters have the following values: f=2.74 mm; Fno=2.40; and HFOV=71.1 degrees.

In the photographing optical lens system according to the 1st embodiment, when the half of the maximum field of view of the photographing optical lens system is HFOV, the following condition is satisfied: $|\tan(\text{HFOV})|=0.34$.

In the photographing optical lens system according to the 1st embodiment, when an Abbe number of the second lens element 120 is V2, the following condition is satisfied: $V2=23.3$.

In the photographing optical lens system according to the 1st embodiment, when an Abbe number of the fourth lens element 140 is V4, the following condition is satisfied: $V4=20.4$.

In the photographing optical lens system according to the 1st embodiment, when an axial distance between the first lens element 110 and the second lens element 120 is T12, and a central thickness of the first lens element 110 is CT1, the following condition is satisfied: $T12/CT1=2.02$.

In the photographing optical lens system according to the 1st embodiment, when an axial distance between the image-side surface 162 of the sixth lens element 160 and the image surface 180 is BL, and an axial distance between the fifth lens element 150 and the sixth lens element 160 is T56, the following condition is satisfied: $BL/T56=0.82$.

In the photographing optical lens system according to the 1st embodiment, when the axial distance between the image-side surface 162 of the sixth lens element 160 and the image surface 180 is BL, and an axial distance between the object-side surface 111 of the first lens element 110 and the image surface 180 is TL, the following condition is satisfied: $BL/TL=0.09$.

In the photographing optical lens system according to the 1st embodiment, when an axial distance between the aper-

11

ture stop **100** and the image-side surface **162** of the sixth lens element **160** is SD, and an axial distance between the object-side surface **111** of the first lens element **110** and the image-side surface **162** of the sixth lens element **160** is TD, the following condition is satisfied: SD/TD=0.50.

In the photographing optical lens system according to the 1st embodiment, when a curvature radius of the image-side surface **132** of the third lens element **130** is R6, and a curvature radius of the object-side surface **141** of the fourth lens element **140** is R7, the following condition is satisfied: |R6/R7|=0.07.

In the photographing optical lens system according to the 1st embodiment, when a curvature radius of the object-side surface **131** of the third lens element **130** is R5, and the curvature radius of the image-side surface **132** of the third lens element **130** is R6, the following condition is satisfied: (R5+R6)/(R5-R6)=0.02.

In the photographing optical lens system according to the 1st embodiment, when a curvature radius of the object-side surface **161** of the sixth lens element **160** is R11, and a curvature radius of the image-side surface **162** of the sixth lens element **160** is R12, the following condition is satisfied: (R11-R12)/(R11+R12)=-0.70.

In the photographing optical lens system according to the 1st embodiment, when a curvature radius of the image-side surface **112** of the first lens element **110** is R2, and the curvature radius of the object-side surface **161** of the sixth lens element **160** is R11, the following condition is satisfied: (R2+R11)/(R2-R11)=-0.47.

FIG. 21 shows a schematic view of a parameter Y61 of the sixth lens element **160** according to the 1st embodiment. When the curvature radius of the object-side surface **161** of the sixth lens element **160** is R11, and a vertical distance between a maximum effective diameter position on the object-side surface **161** of the sixth lens element **160** and the optical axis is Y61, the following condition is satisfied: R11/Y61=-1.42.

In the photographing optical lens system according to the 1st embodiment, when the focal length of the photographing optical lens system is f, and a central thickness of the second lens element **120** is CT2, the following condition is satisfied: f/CT2=1.68.

In the photographing optical lens system according to the 1st embodiment, when a composite focal length of lens elements between an imaged object (not shown) and the aperture stop **100** is ff (in the 1st embodiment, ff is a

12

composite focal length of the first lens element **110** and second lens element **120**), and a composite focal length of lens elements between the aperture stop **100** and the image surface **180** is fr (in the 1st embodiment, fr is a composite focal length of the third lens element **130**, the fourth lens element **140**, the fifth lens element **150** and the sixth lens element **160**), the following condition is satisfied: |fr/ff|=0.40.

In the photographing optical lens system according to the 1st embodiment, when a refractive power of the first lens element **110** is P1 (P1 equals to a ratio of the focal length of the photographing optical lens system and a focal length of the first lens element **110**, i.e., P1=f/f1), a refractive power of the second lens element **120** is P2 (P2 equals to a ratio of the focal length of the photographing optical lens system and a focal length of the second lens element **120**, i.e., P2=f/f2), a refractive power of the third lens element **130** is P3 (P3 equals to a ratio of the focal length of the photographing optical lens system and a focal length of the third lens element **130**, i.e., P3=f/f3), a refractive power of the fourth lens element **140** is P4 (P4 equals to a ratio of the focal length of the photographing optical lens system and a focal length of the fourth lens element **140**, i.e., P4=f/f4), a refractive power of the fifth lens element **150** is P5 (P5 equals to a ratio of the focal length of the photographing optical lens system and a focal length of the fifth lens element **150**, i.e., P5=f/f5), and a refractive power of the sixth lens element **160** is P6 (P6 equals to a ratio of the focal length of the photographing optical lens system and a focal length of the sixth lens element **160**, i.e., P6=f/f6), the following conditions are satisfied: |P3|>|P1|; |P3|>|P2|; |P3|>|P5|; |P3|>|P6|; |P4|>|P1|; |P4|>|P2|; |P4|>|P5|; and |P4|>|P6|.

In the photographing optical lens system according to the 1st embodiment, when the axial distance between the first lens element **110** and the second lens element **120** is T12, an axial distance between the second lens element **120** and the third lens element **130** is T23, an axial distance between the third lens element **130** and the fourth lens element **140** is T34, an axial distance between the fourth lens element **140** and the fifth lens element **150** is T45, and the axial distance between the fifth lens element **150** and the sixth lens element **160** is T56, the following conditions are satisfied: T12>T23; T12>T34; T12>T45; T56>T23; T56>T34; and T56>T45.

The detailed optical data of the 1st embodiment are shown in Table 1 and the aspheric surface data are shown in Table 2 below.

TABLE 1

1st Embodiment							
f = 2.74 mm, Fno = 2.40, HFOV = 71.1 deg.							
Surface #		Curvature Radius	Thickness	Material	Index	Abbe #	Focal Length
0	Object	Plano	Infinity				
1	Lens 1	3.214 ASP	0.980	Plastic	1.544	55.9	-4.84
2		1.291 ASP	1.976				
3	Lens 2	-8.194 ASP	1.637	Plastic	1.639	23.3	19.53
4		-5.330 ASP	0.401				
5	Ape. Stop	Plano	-0.205				
6	Lens 3	2.508 ASP	1.075	Plastic	1.544	55.9	2.45
7		-2.405 ASP	0.092				
8	Lens 4	-32.258 ASP	0.499	Plastic	1.660	20.4	-3.82
9		2.750 ASP	0.620				
10	Lens 5	-5.210 ASP	1.079	Plastic	1.544	55.9	4.37
11		-1.750 ASP	1.211				
12	Lens 6	-3.591 ASP	0.645	Plastic	1.650	21.5	-6.83
13		-20.047 ASP	0.250				
14	IR-cut filter	Plano	0.210	Glass	1.517	64.2	—

TABLE 1-continued

1st Embodiment						
f = 2.74 mm, Fno = 2.40, HFOV = 71.1 deg.						
Surface #		Curvature Radius	Thickness	Material	Index	Abbe # Focal Length
15		Plano	0.528			
16	Image	Plano	—			

Note:
Reference wavelength is 587.6 nm (d-line).

TABLE 2

Aspheric Coefficients							
Surface #	1	2	3	4	6	7	
k =	-8.4811E-01	-8.6526E-01	-8.4016E+01	-4.4709E+01	-7.0373E+00	-3.2165E+00	
A4 =	-8.8434E-04	1.4975E-02	-2.4964E-02	-2.4502E-02	7.7924E-02	4.6759E-02	
A6 =	-1.5726E-03	-4.2952E-03	3.7438E-03	-2.7093E-03	-2.8041E-02	-7.6043E-02	
A8 =	1.1048E-04	1.6034E-03	-2.6085E-03	1.2525E-02	9.2952E-03	6.2610E-02	
A10 =	3.7551E-07	-4.4529E-04	8.4511E-04	-5.6567E-03	1.3218E-02	-1.2950E-02	
A12 =	-1.8370E-07	2.5238E-06	-8.9426E-05	1.3053E-03	-6.0121E-03	5.2185E-03	
Surface #	8	9	10	11	12	13	
k =	9.0000E+01	-1.3462E+01	-5.8225E+00	-8.0813E-01	-7.1352E-01	-2.1347E+01	
A4 =	-2.5037E-02	1.5865E-02	-1.0967E-02	1.4625E-02	-1.0721E-02	1.2351E-02	
A6 =	-7.5945E-02	-2.1706E-02	1.2851E-02	-1.4034E-02	-1.4362E-03	-1.9316E-02	
A8 =	6.9398E-02	1.3071E-02	-2.6787E-03	1.9237E-02	7.3560E-03	8.7113E-03	
A10 =	-1.6744E-02	1.3643E-03	5.1700E-04	-9.1965E-03	-3.2262E-03	-1.9777E-03	
A12 =	-2.4297E-04	-2.7748E-03	-9.4089E-05	2.2327E-03	6.3266E-04	2.4319E-04	
A14 =	1.1674E-15	5.4299E-04	1.3189E-15	-2.1281E-04	-5.9707E-05	-1.5365E-05	
A16 =					2.1952E-06	3.8905E-07	

In Table 1, the curvature radius, the thickness and the focal length are shown in millimeters (mm). Surface numbers 0-16 represent the surfaces sequentially arranged from the object-side to the image-side along the optical axis. In Table 2, k represents the conic coefficient of the equation of the aspheric surface profiles. A4-A16 represent the aspheric coefficients ranging from the 4th order to the 16th order. The tables presented below for each embodiment are the corresponding schematic parameter and aberration curves, and the definitions of the tables are the same as Table 1 and Table 2 of the 1st embodiment. Therefore, an explanation in this regard will not be provided again.

2nd Embodiment

FIG. 3 is a schematic view of an image capturing apparatus according to the 2nd embodiment of the present disclosure. FIG. 4 shows spherical aberration curves, astigmatic field curves and a distortion curve of the image capturing apparatus according to the 2nd embodiment. In FIG. 3, the image capturing apparatus includes a photographing optical lens system (its reference numeral is omitted) and an image sensor 290. The photographing optical lens system includes, in order from an object side to an image side, a first lens element 210, a second lens element 220, an aperture stop 200, a third lens element 230, a fourth lens element 240, a fifth lens element 250, a sixth lens element 260, an IR-cut filter 270 and an image surface 280, wherein the image sensor 290 is disposed on the image surface 280 of the photographing optical lens system. The photographing optical lens system has a total of six lens elements (210-260), and there is an air space between every two lens elements of the first lens element 210, the second

lens element 220, the third lens element 230, the fourth lens element 240, the fifth lens element 250 and the sixth lens element 260 that are adjacent to each other.

The first lens element 210 with negative refractive power has an object-side surface 211 being convex in a paraxial region thereof and an image-side surface 212 being concave in a paraxial region thereof. The first lens element 210 is made of a plastic material, and has the object-side surface 211 and the image-side surface 212 being both aspheric.

The second lens element 220 with positive refractive power has an object-side surface 221 being concave in a paraxial region thereof and an image-side surface 222 being convex in a paraxial region thereof. The second lens element 220 is made of a plastic material, and has the object-side surface 221 and the image-side surface 222 being both aspheric.

The third lens element 230 with positive refractive power has an object-side surface 231 being convex in a paraxial region thereof and an image-side surface 232 being convex in a paraxial region thereof. The third lens element 230 is made of a plastic material, and has the object-side surface 231 and the image-side surface 232 being both aspheric.

The fourth lens element 240 with negative refractive power has an object-side surface 241 being convex in a paraxial region thereof and an image-side surface 242 being concave in a paraxial region thereof. The fourth lens element 240 is made of a plastic material, and has the object-side surface 241 and the image-side surface 242 being both aspheric.

The fifth lens element 250 with positive refractive power has an object-side surface 251 being convex in a paraxial region thereof and an image-side surface 252 being convex in a paraxial region thereof. The fifth lens element 250 is

15

made of a plastic material, and has the object-side surface 251 and the image-side surface 252 being both aspheric.

The sixth lens element 260 with negative refractive power has an object-side surface 261 being concave in a paraxial region thereof and an image-side surface 262 being convex in a paraxial region thereof. The sixth lens element 260 is made of a plastic material, and has the object-side surface 261 and the image-side surface 262 being both aspheric. Furthermore, the object-side surface 261 and the image-side surface 262 of the sixth lens element 260 include at least one inflection point.

The IR-cut filter 270 is made of a glass material and located between the sixth lens element 260 and the image surface 280, and will not affect the focal length of the photographing optical lens system.

The detailed optical data of the 2nd embodiment are shown in Table 3 and the aspheric surface data are shown in Table 4 below.

TABLE 3

2nd Embodiment							
f = 2.75 mm, Fno = 2.43, HFOV = 68.2 deg.							
Surface #		Curvature Radius	Thickness	Material	Index	Abbe #	Focal Length
0	Object	Plano	Infinity				
1	Lens 1	2.864 ASP	0.922	Plastic	1.544	55.9	-5.18
2		1.259 ASP	1.970				
3	Lens 2	-10.353 ASP	1.682	Plastic	1.639	23.3	16.58
4		-5.566 ASP	0.535				
5	Ape. Stop	Plano	-0.162				
6	Lens 3	2.789 ASP	0.756	Plastic	1.544	55.9	2.63
7		-2.661 ASP	0.049				
8	Lens 4	16.273 ASP	0.493	Plastic	1.660	20.4	-4.22
9		2.351 ASP	0.954				
10	Lens 5	24.390 ASP	0.978	Plastic	1.544	55.9	4.60
11		-2.745 ASP	1.337				
12	Lens 6	-3.414 ASP	0.705	Plastic	1.650	21.5	-7.17
13		-13.766 ASP	0.250				
14	IR-cut filter	Plano	0.210	Glass	1.517	64.2	—
15		Plano	0.166				
16	Image	Plano	—				

Note:
Reference wavelength is 587.6 nm (d-line).

TABLE 4

Aspheric Coefficients							
Surface #	1	2	3	4	6	7	
k =	-9.2536E-01	-8.6696E-01	-8.8333E+01	-9.3955E+00	-9.2478E+00	-2.8069E+00	
A4 =	-8.8434E-04	1.4975E-02	-2.3205E-02	-1.4270E-02	6.7344E-02	6.2813E-02	
A6 =	-1.5726E-03	-4.2952E-03	2.9398E-03	-2.1565E-03	-2.2460E-02	-1.0179E-01	
A8 =	1.1048E-04	1.6034E-03	-2.7335E-03	7.5357E-03	2.1687E-03	7.6945E-02	
A10 =	3.7551E-07	-4.4529E-04	9.5603E-04	-4.3006E-03	1.8041E-02	-1.4525E-02	
A12 =	-1.8370E-07	2.5238E-06	-8.9426E-05	1.3053E-03	-6.0121E-03	5.2185E-03	
Surface #	8	9	10	11	12	13	
k =	9.0000E+01	-1.0237E+01	-6.0426E+01	-7.7147E-01	-6.1820E-01	-9.0000E+01	
A4 =	-2.5037E-02	1.5865E-02	-1.9085E-02	-1.0947E-02	-8.6315E-02	-1.5595E-02	
A6 =	-7.5945E-02	-2.1706E-02	2.8760E-02	1.5444E-02	6.8504E-02	6.7453E-03	
A8 =	6.9398E-02	1.3071E-02	-1.0946E-02	4.7779E-03	-2.2889E-02	-9.0838E-04	
A10 =	-1.6744E-02	1.3643E-03	1.9990E-03	-3.5235E-03	4.4832E-03	2.2294E-06	
A12 =	-2.4297E-04	-2.7748E-03	-1.5994E-04	6.7285E-04	-5.4032E-04	9.4290E-06	
A14 =	-1.1378E-13	5.4299E-04	2.0464E-06	-4.3784E-05	3.7118E-05	-7.9989E-07	
A16 =					-1.0998E-06	2.1137E-08	

16

In the 2nd embodiment, the equation of the aspheric surface profiles of the aforementioned lens elements is the same as the equation of the 1st embodiment. Also, the definitions of these parameters shown in the following table are the same as those stated in the 1st embodiment with corresponding values for the 2nd embodiment, so an explanation in this regard will not be provided again.

Moreover, these parameters can be calculated from Table 3 and Table 4 as the following values and satisfy the following conditions:

2nd Embodiment			
f [mm]	2.75	SD/TD	0.50
Fno	2.43	R6/R7	0.16
HFOV [deg.]	68.2	(R5 + R6)/(R5 - R6)	0.02
1/tan(HFOV)	0.40	(R11 - R12)/(R11 + R12)	-0.60

-continued

2nd Embodiment			
V2	23.3	$(R2 + R11)/(R2 - R11)$	-0.46
V4	20.4	$R11/Y61$	-1.32
T12/CT1	2.14	$f/CT2$	1.64
BL/T56	0.47	$ f/\#1 $	0.32
BL/TL	0.06		

In the photographing optical lens system according to the 2nd embodiment, when a refractive power of the first lens element 210 is P1, a refractive power of the second lens element 220 is P2, a refractive power of the third lens element 230 is P3, a refractive power of the fourth lens element 240 is P4, a refractive power of the fifth lens element 250 is P5, and a refractive power of the sixth lens element 260 is P6, the following conditions are satisfied: $|P3| > |P1|$; $|P3| > |P2|$; $|P3| > |P5|$; $|P3| > |P6|$; $|P4| > |P4| > |P2|$; $|P4| > |P5|$; and $|P4| > |P6|$.

In the photographing optical lens system according to the 2nd embodiment, when an axial distance between the first lens element 210 and the second lens element 220 is T12, an axial distance between the second lens element 220 and the third lens element 230 is T23, an axial distance between the third lens element 230 and the fourth lens element 240 is T34, an axial distance between the fourth lens element 240 and the fifth lens element 250 is T45, and an axial distance between the fifth lens element 250 and the sixth lens element 260 is T56, the following conditions are satisfied: $T12 > T23$; $T12 > T34$; $T12 > T45$; $T56 > T23$; $T56 > T34$; and $T56 > T45$.

3rd Embodiment

FIG. 5 is a schematic view of an image capturing apparatus according to the 3rd embodiment of the present disclosure. FIG. 6 shows spherical aberration curves, astigmatic field curves and a distortion curve of the image capturing apparatus according to the 3rd embodiment. In FIG. 5, the image capturing apparatus includes a photographing optical lens system (its reference numeral is omitted) and an image sensor 390. The photographing optical lens system includes, in order from an object side to an image side, a first lens element 310, a second lens element 320, an aperture stop 300, a third lens element 330, a fourth lens element 340, a fifth lens element 350, a sixth lens element 360, an IR-cut filter 370 and an image surface 380, wherein the image sensor 390 is disposed on the image surface 380 of the photographing optical lens system. The photographing optical lens system has a total of six lens elements (310-360), and there is an air space between every

two lens elements of the first lens element 310, the second lens element 320, the third lens element 330, the fourth lens element 340, the fifth lens element 350 and the sixth lens element 360 that are adjacent to each other.

The first lens element 310 with negative refractive power has an object-side surface 311 being convex in a paraxial region thereof and an image-side surface 312 being concave in a paraxial region thereof. The first lens element 310 is made of a plastic material, and has the object-side surface 311 and the image-side surface 312 being both aspheric.

The second lens element 320 with negative refractive power has an object-side surface 321 being concave in a paraxial region thereof and an image-side surface 322 being convex in a paraxial region thereof. The second lens element 320 is made of a plastic material, and has the object-side surface 321 and the image-side surface 322 being both aspheric.

The third lens element 330 with positive refractive power has an object-side surface 331 being convex in a paraxial region thereof and an image-side surface 332 being convex in a paraxial region thereof. The third lens element 330 is made of a plastic material, and has the object-side surface 331 and the image-side surface 332 being both aspheric.

The fourth lens element 340 with negative refractive power has an object-side surface 341 being convex in a paraxial region thereof and an image-side surface 342 being concave in a paraxial region thereof. The fourth lens element 340 is made of a plastic material, and has the object-side surface 341 and the image-side surface 342 being both aspheric.

The fifth lens element 350 with positive refractive power has an object-side surface 351 being concave in a paraxial region thereof and an image-side surface 352 being convex in a paraxial region thereof. The fifth lens element 350 is made of a plastic material, and has the object-side surface 351 and the image-side surface 352 being both aspheric.

The sixth lens element 360 with negative refractive power has an object-side surface 361 being concave in a paraxial region thereof and an image-side surface 362 being convex in a paraxial region thereof. The sixth lens element 360 is made of a plastic material, and has the object-side surface 361 and the image-side surface 362 being both aspheric. Furthermore, the object-side surface 361 of the sixth lens element 360 includes at least one inflection point.

The IR-cut filter 370 is made of a glass material and located between the sixth lens element 360 and the image surface 380, and will not affect the focal length of the photographing optical lens system.

The detailed optical data of the 3rd embodiment are shown in Table 5 and the aspheric surface data are shown in Table 6 below.

TABLE 5

3rd Embodiment							
$f = 2.65 \text{ mm}$, $Fno = 2.08$, $HFOV = 80.7 \text{ deg.}$							
Surface #		Curvature Radius	Thickness	Material	Index	Abbe #	Focal Length
0	Object	Plano	Infinity				
1	Lens 1	3.251 ASP	0.816	Plastic	1.544	55.9	-4.80
2		1.319 ASP	1.821				
3	Lens 2	-7.830 ASP	1.591	Plastic	1.639	23.3	-59.23
4		-10.655 ASP	0.397				
5	Ape. Stop	Plano	-0.235				
6	Lens 3	2.159 ASP	1.217	Plastic	1.544	55.9	2.33
7		-2.462 ASP	0.051				
8	Lens 4	9.099 ASP	0.564	Plastic	1.660	20.4	-4.64

TABLE 5-continued

3rd Embodiment							
f = 2.65 mm, Fno = 2.08, HFOV = 80.7 deg.							
Surface #		Curvature Radius	Thickness	Material	Index	Abbe #	Focal Length
9		2.235 ASP	0.723				
10	Lens 5	-8.851 ASP	0.890	Plastic	1.544	55.9	4.85
11		-2.104 ASP	1.290				
12	Lens 6	-3.732 ASP	0.549	Plastic	1.639	23.3	-6.56
13		-35.976 ASP	0.250				
14	IR-cut filter	Plano	0.210	Glass	1.517	64.2	—
15		Plano	0.282				
16	Image	Plano	—				

Note:
Reference wavelength is 587.6 nm (d-line).

TABLE 6

Aspheric Coefficients						
Surface #	1	2	3	4	6	7
k =	-8.5763E-01	-7.4265E-01	-4.7819E+01	4.1003E+01	-7.2187E+00	-1.1610E+00
A4 =	-8.8434E-04	1.4975E-02	-2.1982E-02	-4.3624E-02	3.1676E-02	2.2898E-02
A6 =	-1.5726E-03	-4.2952E-03	4.3302E-03	3.1795E-02	-1.7818E-03	-6.7105E-02
A8 =	1.1048E-04	1.6034E-03	-2.9557E-03	-8.9712E-03	-8.7531E-03	7.7991E-02
A10 =	3.7551E-07	-4.4529E-04	9.4799E-04	-3.6874E-04	1.3546E-02	-3.7559E-02
A12 =	-1.8370E-07	2.5238E-06	-8.9426E-05	1.3053E-03	-6.0121E-03	5.2185E-03
Surface #	8	9	10	11	12	13
k =	-4.1233E+01	-9.4216E+00	2.0238E+01	-7.5418E-01	2.1920E-01	7.4119E+01
A4 =	-5.1709E-02	1.7743E-02	-1.0164E-02	5.2142E-03	-7.2729E-03	-6.2775E-03
A6 =	-3.1009E-02	-1.6790E-02	1.3351E-02	5.7844E-03	3.4024E-03	-1.0945E-04
A8 =	4.7291E-02	9.8225E-03	-2.5156E-03	-4.7810E-04	4.4652E-04	1.0577E-04
A10 =	-1.7856E-02	1.9194E-03	5.7445E-04	5.2942E-04	-2.4902E-04	4.2734E-06
A12 =	-2.4297E-04	-2.7748E-03	-9.4089E-05	-1.2208E-04	3.7078E-05	-3.0380E-06
A14 =	-2.4994E-19	5.4299E-04	-2.8527E-19	1.4340E-06	-2.4888E-06	2.6933E-07
A16 =					6.4995E-08	-7.6831E-09

In the 3rd embodiment, the equation of the aspheric surface profiles of the aforementioned lens elements is the same as the equation of the 1st embodiment. Also, the definitions of these parameters shown in the following table are the same as those stated in the 1st embodiment with corresponding values for the 3rd embodiment, so an explanation in this regard will not be provided again.

Moreover, these parameters can be calculated from Table 5 and Table 6 as the following values and satisfy the following conditions:

3rd Embodiment			
f [mm]	2.65	SD/TD	0.52
Fno	2.08	R6/R7	0.27
HFOV [deg.]	80.7	(R5 + R6)/(R5 - R6)	-0.07
1/tan(HFOV)	0.16	(R11 - R12)/(R11 + R12)	-0.81
V2	23.3	(R2 + R11)/(R2 - R11)	-0.48
V4	20.4	R11/Y61	-1.34
T12/CT1	2.23	f/CT2	1.67
BL/T56	0.58	f _r /f _l	0.59
BL/TL	0.07		

In the photographing optical lens system according to the 3rd embodiment, when a refractive power of the first lens element 310 is P1, a refractive power of the second lens element 320 is P2, a refractive power of the third lens element 330 is P3, a refractive power of the fourth lens element 340 is P4, a refractive power of the fifth lens element 350 is P5, and a refractive power of the sixth lens

element 360 is P6, the following conditions are satisfied: |P3|>|P1|; |P3|>|P2|; |P3|>|P5|; |P3|>|P6|; |P4|>|P1|; |P4|>|P2|; |P4|>|P5|; and |P4|>|P6|.

In the photographing optical lens system according to the 3rd embodiment, when an axial distance between the first lens element 310 and the second lens element 320 is T12, an axial distance between the second lens element 320 and the third lens element 330 is T23, an axial distance between the third lens element 330 and the fourth lens element 340 is T34, an axial distance between the fourth lens element 340 and the fifth lens element 350 is T45, and an axial distance between the fifth lens element 350 and the sixth lens element 360 is T56, the following conditions are satisfied: T12>T23; T12>T34; T12>T45; T56>T23; T56>T34; and T56>T45.

4th Embodiment

FIG. 7 is a schematic view of an image capturing apparatus according to the 4th embodiment of the present disclosure. FIG. 8 shows spherical aberration curves, astigmatic field curves and a distortion curve of the image capturing apparatus according to the 4th embodiment. In FIG. 7, the image capturing apparatus includes a photographing optical lens system (its reference numeral is omitted) and an image sensor 490. The photographing optical lens system includes, in order from an object side to an image side, a first lens element 410, a second lens element 420, an aperture stop 400, a third lens element 430, a fourth lens element 440, a fifth lens element 450, a sixth lens

21

element 460, an IR-cut filter 470 and an image surface 480, wherein the image sensor 490 is disposed on the image surface 480 of the photographing optical lens system. The photographing optical lens system has a total of six lens elements (410-460), and there is an air space between every two lens elements of the first lens element 410, the second lens element 420, the third lens element 430, the fourth lens element 440, the fifth lens element 450 and the sixth lens element 460 that are adjacent to each other.

The first lens element 410 with negative refractive power has an object-side surface 411 being convex in a paraxial region thereof and an image-side surface 412 being concave in a paraxial region thereof. The first lens element 410 is made of a plastic material, and has the object-side surface 411 and the image-side surface 412 being both aspheric.

The second lens element 420 with positive refractive power has an object-side surface 421 being convex in a paraxial region thereof and an image-side surface 422 being convex in a paraxial region thereof. The second lens element 420 is made of a plastic material, and has the object-side surface 421 and the image-side surface 422 being both aspheric.

The third lens element 430 with positive refractive power has an object-side surface 431 being convex in a paraxial region thereof and an image-side surface 432 being convex in a paraxial region thereof. The third lens element 430 is made of a plastic material, and has the object-side surface 431 and the image-side surface 432 being both aspheric.

22

The fourth lens element 440 with negative refractive power has an object-side surface 441 being convex in a paraxial region thereof and an image-side surface 442 being concave in a paraxial region thereof. The fourth lens element 440 is made of a plastic material, and has the object-side surface 441 and the image-side surface 442 being both aspheric.

The fifth lens element 450 with positive refractive power has an object-side surface 451 being concave in a paraxial region thereof and an image-side surface 452 being convex in a paraxial region thereof. The fifth lens element 450 is made of a plastic material, and has the object-side surface 451 and the image-side surface 452 being both aspheric.

The sixth lens element 460 with negative refractive power has an object-side surface 461 being concave in a paraxial region thereof and an image-side surface 462 being convex in a paraxial region thereof. The sixth lens element 460 is made of a plastic material, and has the object-side surface 461 and the image-side surface 462 being both aspheric. Furthermore, the object-side surface 461 of the sixth lens element 460 includes at least one inflection point.

The IR-cut filter 470 is made of a glass material and located between the sixth lens element 460 and the image surface 480, and will not affect the focal length of the photographing optical lens system.

The detailed optical data of the 4th embodiment are shown in Table 7 and the aspheric surface data are shown in Table 8 below.

TABLE 7

4th Embodiment								
f = 2.76 mm, Fno = 2.25, HFOV = 77.2 deg.								
Surface #		Curvature	Radius	Thickness	Material	Index	Abbe #	Focal Length
0	Object	Plano		Infinity				
1	Lens 1	3.173	ASP	0.864	Plastic	1.544	55.9	-4.31
2		1.218	ASP	1.810				
3	Lens 2	83.333	ASP	1.650	Plastic	1.639	23.3	46.66
4		-46.034	ASP	0.384				
5	Ape. Stop	Plano		-0.165				
6	Lens 3	2.941	ASP	0.894	Plastic	1.544	55.9	2.58
7		-2.402	ASP	0.050				
8	Lens 4	5.587	ASP	0.533	Plastic	1.660	20.4	-5.61
9		2.142	ASP	0.562				
10	Lens 5	-8.644	ASP	0.819	Plastic	1.544	55.9	4.65
11		-2.022	ASP	1.406				
12	Lens 6	-3.611	ASP	0.480	Plastic	1.639	23.3	-6.51
13		-28.810	ASP	0.250				
14	IR-cut filter	Plano		0.210	Glass	1.517	64.2	—
15		Plano		0.731				
16	Image	Plano		—				

Note: Reference wavelength is 587.6 nm (d-line).

TABLE 8

Aspheric Coefficients						
Surface #	1	2	3	4	6	7
k =	-7.9438E-01	-7.1225E-01	-3.1509E+01	5.9037E+01	2.1617E+00	1.6987E+00
A4 =	-8.8434E-04	1.4975E-02	-2.1251E-02	-2.7130E-03	-2.2694E-02	3.8027E-02
A6 =	-1.5726E-03	-4.2952E-03	1.7624E-02	-5.5472E-02	1.1355E-02	-3.1360E-02
A8 =	1.1048E-04	1.6034E-03	-1.5437E-02	8.9996E-02	-4.4025E-02	2.6190E-02
A10 =	3.7551E-07	-4.4529E-04	5.3513E-03	-6.2344E-02	3.3450E-02	-9.3163E-03
A12 =	-1.8370E-07	2.5238E-06	-6.5685E-04	1.8496E-02	-6.0121E-03	5.2185E-03

TABLE 8-continued

Aspheric Coefficients						
Surface #	8	9	10	11	12	13
k =	-3.3284E+01	-8.7823E+00	2.4083E+01	-6.4214E-01	1.5637E-01	7.7200E+01
A4 =	-3.9789E-02	1.8993E-02	-7.3958E-03	2.7581E-03	-1.2926E-02	-8.0770E-03
A6 =	-3.3079E-02	-2.3139E-02	1.3476E-02	5.5019E-03	8.6961E-03	4.9101E-04
A8 =	3.2533E-02	1.2216E-02	-2.3841E-03	-4.1748E-04	-6.5561E-04	6.3862E-04
A10 =	-6.0273E-03	1.8094E-03	5.8443E-04	5.6660E-04	-4.3932E-04	-2.7967E-04
A12 =	-2.4297E-04	-2.7748E-03	-9.4089E-05	-1.2208E-04	1.4200E-04	4.8744E-05
A14 =	5.6551E-13	5.4299E-04	6.4534E-13	1.4340E-06	-1.6590E-05	-3.8718E-06
A16 =					6.9621E-07	1.1557E-07

In the 4th embodiment, the equation of the aspheric surface profiles of the aforementioned lens elements is the same as the equation of the 1st embodiment. Also, the definitions of these parameters shown in the following table are the same as those stated in the 1st embodiment with corresponding values for the 4th embodiment, so an explanation in this regard will not be provided again.

Moreover, these parameters can be calculated from Table 7 and Table 8 as the following values and satisfy the following conditions:

4th Embodiment			
f [mm]	2.76	SD/TD	0.49
Fno	2.25	R6/R7	0.43
HFOV [deg.]	77.2	(R5 + R6)/(R5 - R6)	0.10
1/ tan(HFOV)	0.23	(R11 - R12)/(R11 + R12)	-0.78
V2	23.3	(R2 + R11)/(R2 - R11)	-0.50
V4	20.4	R11/Y61	-1.41
T12/CT1	2.09	f/CT2	1.67
BL/T56	0.85	f _g /f _l	0.56
BL/TL	0.11		

In the photographing optical lens system according to the 4th embodiment, when an axial distance between the first lens element 410 and the second lens element 420 is T12, an axial distance between the second lens element 420 and the third lens element 430 is T23, an axial distance between the third lens element 430 and the fourth lens element 440 is T34, an axial distance between the fourth lens element 440 and the fifth lens element 450 is T45, and an axial distance between the fifth lens element 450 and the sixth lens element 460 is T56, the following conditions are satisfied: T12>T23; T12>T34; T12>T45; T56>T23; T56>T34; and T56>T45.

5th Embodiment

FIG. 9 is a schematic view of an image capturing apparatus according to the 5th embodiment of the present disclosure. FIG. 10 shows spherical aberration curves, astigmatic field curves and a distortion curve of the image capturing apparatus according to the 5th embodiment. In FIG. 9, the image capturing apparatus includes a photographing optical lens system (its reference numeral is omitted) and an image sensor 590. The photographing optical lens system includes, in order from an object side to an image side, a first lens element 510, a second lens element 520, an aperture stop 500, a third lens element 530, a fourth lens element 540, a fifth lens element 550, a sixth lens element 560, an IR-cut filter 570 and an image surface 580, wherein the image sensor 590 is disposed on the image surface 580 of the photographing optical lens system. The photographing optical lens system has a total of six lens elements (510-560), and there is an air space between every

two lens elements of the first lens element 510, the second lens element 520, the third lens element 530, the fourth lens element 540, the fifth lens element 550 and the sixth lens element 560 that are adjacent to each other.

The first lens element 510 with negative refractive power has an object-side surface 511 being convex in a paraxial region thereof and an image-side surface 512 being concave in a paraxial region thereof. The first lens element 510 is made of a glass material, and has the object-side surface 511 and the image-side surface 512 being both aspheric.

The second lens element 520 with negative refractive power has an object-side surface 521 being concave in a paraxial region thereof and an image-side surface 522 being convex in a paraxial region thereof. The second lens element 520 is made of a plastic material, and has the object-side surface 521 and the image-side surface 522 being both aspheric.

The third lens element 530 with positive refractive power has an object-side surface 531 being convex in a paraxial region thereof and an image-side surface 532 being convex in a paraxial region thereof. The third lens element 530 is made of a plastic material, and has the object-side surface 531 and the image-side surface 532 being both aspheric.

The fourth lens element 540 with negative refractive power has an object-side surface 541 being convex in a paraxial region thereof and an image-side surface 542 being concave in a paraxial region thereof. The fourth lens element 540 is made of a plastic material, and has the object-side surface 541 and the image-side surface 542 being both aspheric.

The fifth lens element 550 with positive refractive power has an object-side surface 551 being concave in a paraxial region thereof and an image-side surface 552 being convex in a paraxial region thereof. The fifth lens element 550 is made of a plastic material, and has the object-side surface 551 and the image-side surface 552 being both aspheric.

The sixth lens element 560 with negative refractive power has an object-side surface 561 being concave in a paraxial region thereof and an image-side surface 562 being convex in a paraxial region thereof. The sixth lens element 560 is made of a plastic material, and has the object-side surface 561 and the image-side surface 562 being both aspheric. Furthermore, the object-side surface 561 of the sixth lens element 560 includes at least one inflection point.

The IR-cut filter 570 is made of a glass material and located between the sixth lens element 560 and the image surface 580, and will not affect the focal length of the photographing optical lens system.

The detailed optical data of the 5th embodiment are shown in Table 9 and the aspheric surface data are shown in Table 10 below.

TABLE 9

5th Embodiment								
f = 2.69 mm, Fno = 2.32, HFOV = 81.4 deg.								
Surface #		Curvature Radius	Thickness	Material	Index	Abbe #	Focal Length	
0	Object	Plano	Infinity					
1	Lens 1	3.244 ASP	0.861	Glass	1.589	61.3	-4.77	
2		1.358 ASP	1.845					
3	Lens 2	-8.342 ASP	1.591	Plastic	1.639	23.3	-51.75	
4		-11.988 ASP	0.409					
5	Ape. Stop	Plano	-0.205					
6	Lens 3	2.315 ASP	1.170	Plastic	1.544	55.9	2.33	
7		-2.308 ASP	0.112					
8	Lens 4	8.856 ASP	0.557	Plastic	1.660	20.4	-4.48	
9		2.162 ASP	0.681					
10	Lens 5	-9.105 ASP	0.888	Plastic	1.544	55.9	4.62	
11		-2.036 ASP	1.268					
12	Lens 6	-3.398 ASP	0.642	Plastic	1.639	23.3	-6.52	
13		-19.810 ASP	0.250					
14	IR-cut filter	Plano	0.210	Glass	1.517	64.2	—	
15		Plano	0.347					
16	Image	Plano	—					

Note: Reference wavelength is 587.6 nm (d-line).

TABLE 10

Aspheric Coefficients						
Surface #	1	2	3	4	6	7
k =	-8.4392E-01	-8.4824E-01	-4.3706E+01	-3.9165E+01	-2.5637E+00	-1.4051E+00
A4 =	-8.6467E-04	1.5883E-02	-2.2367E-02	-2.7644E-02	-1.0947E-02	2.3939E-02
A6 =	-1.5691E-03	-4.2319E-03	5.5102E-03	1.6146E-02	5.0685E-02	-3.0853E-02
A8 =	1.1069E-04	1.5749E-03	-3.1462E-03	2.4420E-04	-4.7069E-02	4.2378E-02
A10 =	2.4302E-07	-4.6698E-04	8.3483E-04	-2.9678E-03	2.6290E-02	-2.6449E-02
A12 =	-1.8370E-07	2.5238E-06	-8.9426E-05	1.3053E-03	-6.0121E-03	5.2185E-03
Surface #	8	9	10	11	12	13
k =	-5.6009E+01	-9.7790E+00	6.3970E+00	-7.7584E-01	-4.6745E-01	2.0866E+01
A4 =	-5.1350E-02	1.8020E-02	-1.0533E-02	5.1030E-03	-7.3476E-03	-5.9290E-03
A6 =	-3.9131E-03	-1.5428E-02	1.3097E-02	5.8877E-03	3.3792E-03	-8.6363E-05
A8 =	1.4126E-02	3.6293E-03	-2.6798E-03	-4.1755E-04	4.4239E-04	1.0759E-04
A10 =	-9.0248E-03	3.7868E-03	4.7720E-04	5.5647E-04	-2.4978E-04	4.4545E-06
A12 =	-2.4297E-04	-2.7748E-03	-9.4089E-05	-1.2208E-04	3.7078E-05	-3.0380E-06
A14 =	8.5988E-20	5.4299E-04	9.8143E-20	1.4340E-06	-2.4888E-06	2.6933E-07
A16 =					6.4995E-08	-7.6831E-09

In the 5th embodiment, the equation of the aspheric surface profiles of the aforementioned lens elements is the same as the equation of the 1st embodiment. Also, the definitions of these parameters shown in the following table are the same as those stated in the 1st embodiment with corresponding values for the 5th embodiment, so an explanation in this regard will not be provided again.

Moreover, these parameters can be calculated from Table 9 and Table 10 as the following values and satisfy the following conditions:

5th Embodiment			
f [mm]	2.69	SD/TD	0.52
Fno	2.32	R6/R7	0.26
HFOV [deg.]	81.4	(R5 + R6)/(R5 - R6)	0.00
1/tan(HFOV)	0.15	(R11 - R12)/(R11 + R12)	-0.71
V2	23.3	(R2 + R11)/(R2 - R11)	-0.43
V4	20.4	R11/Y61	-1.31
T12/CT1	2.14	f/CT2	1.69
BL/T56	0.64	f1/f	0.61
BL/TL	0.08		

In the photographing optical lens system according to the 5th embodiment, when a refractive power of the first lens element 510 is P1, a refractive power of the second lens element 520 is P2, a refractive power of the third lens element 530 is P3, a refractive power of the fourth lens element 540 is P4, a refractive power of the fifth lens element 550 is P5, and a refractive power of the sixth lens element 560 is P6, the following conditions are satisfied: |P3|>|P1|; |P3|>|P2|; |P3|>|P5|; |P3|>|P6|; |P4|>|P1|; |P4|>|P2|; |P4|>|P5|; and |P4|>|P6|.

In the photographing optical lens system according to the 5th embodiment, when an axial distance between the first lens element 510 and the second lens element 520 is T12, an axial distance between the second lens element 520 and the third lens element 530 is T23, an axial distance between the third lens element 530 and the fourth lens element 540 is T34, an axial distance between the fourth lens element 540 and the fifth lens element 550 is T45, and an axial distance between the fifth lens element 550 and the sixth lens element 560 is T56, the following conditions are satisfied: T12>T23; T12>T34; T12>T45; T56>T23; T56>T34; and T56>T45.

FIG. 11 is a schematic view of an image capturing apparatus according to the 6th embodiment of the present disclosure. FIG. 12 shows spherical aberration curves, astigmatic field curves and a distortion curve of the image capturing apparatus according to the 6th embodiment. In FIG. 11, the image capturing apparatus includes a photographing optical lens system (its reference numeral is omitted) and an image sensor 690. The photographing optical lens system includes, in order from an object side to an image side, a first lens element 610, a second lens element 620, an aperture stop 600, a third lens element 630, a fourth lens element 640, a fifth lens element 650, a sixth lens element 660, an IR-cut filter 670 and an image surface 680, wherein the image sensor 690 is disposed on the image surface 680 of the photographing optical lens system. The photographing optical lens system has a total of six lens elements (610-660), and there is an air space between every two lens elements of the first lens element 610, the second lens element 620, the third lens element 630, the fourth lens element 640, the fifth lens element 650 and the sixth lens element 660 that are adjacent to each other.

The first lens element 610 with negative refractive power has an object-side surface 611 being convex in a paraxial region thereof and an image-side surface 612 being concave in a paraxial region thereof. The first lens element 610 is made of a plastic material, and has the object-side surface 611 and the image-side surface 612 being both aspheric.

The second lens element 620 with positive refractive power has an object-side surface 621 being concave in a paraxial region thereof and an image-side surface 622 being convex in a paraxial region thereof. The second lens element 620 is made of a plastic material, and has the object-side surface 621 and the image-side surface 622 being both aspheric.

The third lens element 630 with positive refractive power has an object-side surface 631 being convex in a paraxial region thereof and an image-side surface 632 being convex in a paraxial region thereof. The third lens element 630 is made of a plastic material, and has the object-side surface 631 and the image-side surface 632 being both aspheric.

The fourth lens element 640 with negative refractive power has an object-side surface 641 being concave in a paraxial region thereof and an image-side surface 642 being concave in a paraxial region thereof. The fourth lens element 640 is made of a plastic material, and has the object-side surface 641 and the image-side surface 642 being both aspheric.

The fifth lens element 650 with positive refractive power has an object-side surface 651 being convex in a paraxial region thereof and an image-side surface 652 being convex in a paraxial region thereof. The fifth lens element 650 is made of a plastic material, and has the object-side surface 651 and the image-side surface 652 being both aspheric.

The sixth lens element 660 with negative refractive power has an object-side surface 661 being concave in a paraxial region thereof and an image-side surface 662 being planar in a paraxial region thereof. The sixth lens element 660 is made of a plastic material, and has the object-side surface 661 and the image-side surface 662 being both aspheric. Furthermore, the object-side surface 661 and the image-side surface 662 of the sixth lens element 660 include at least one inflection point.

The IR-cut filter 670 is made of a glass material and located between the sixth lens element 660 and the image surface 680, and will not affect the focal length of the photographing optical lens system.

The detailed optical data of the 6th embodiment are shown in Table 11 and the aspheric surface data are shown in Table 12 below.

TABLE 11

6th Embodiment							
f = 3.63 mm, Fno = 2.46, HFOV = 60.0 deg.							
Surface #		Curvature Radius	Thickness	Material	Index	Abbe #	Focal Length
0	Object	Plano	Infinity				
1	Lens 1	3.290 ASP	0.559	Plastic	1.544	55.9	-7.30
2		1.691 ASP	1.832				
3	Lens 2	-10.015 ASP	1.723	Plastic	1.535	55.8	12.71
4		-4.293 ASP	0.153				
5	Ape. Stop	Plano	-0.080				
6	Lens 3	3.408 ASP	1.477	Plastic	1.535	55.8	2.93
7		-2.465 ASP	0.152				
8	Lens 4	-30.318 ASP	0.330	Plastic	1.639	23.5	-3.53
9		2.448 ASP	0.350				
10	Lens 5	9.408 ASP	0.753	Plastic	1.544	55.9	6.14
11		-5.023 ASP	2.004				
12	Lens 6	-3.390 ASP	0.449	Plastic	1.544	55.9	-6.24
13		Infinity ASP	0.300				
14	IR-cut filter	Plano	0.300	Glass	1.517	64.2	—
15		Plano	0.181				
16	Image	Plano	—				

Note: Reference wavelength is 587.6 nm (d-line).

TABLE 12

Aspheric Coefficients						
Surface #	1	2	3	4	6	7
k =	-7.4920E-01	-7.8264E-01	-5.2350E+01	-8.4672E+00	2.1229E+00	-3.9891E-01
A4 =	-5.8080E-03	3.2856E-03	-1.8950E-02	-1.4844E-02	-7.0633E-03	2.8042E-02
A6 =	-8.1238E-04	-6.9721E-04	1.1658E-03	4.5143E-03	1.9740E-03	-2.5383E-02
A8 =	9.0935E-05	-9.5594E-05	-1.2146E-03	-3.8968E-04	-4.8219E-03	1.2680E-02
A10 =	-1.9596E-06	8.2830E-05	3.2382E-04	2.3645E-04	3.0634E-03	-3.8091E-03
A12 =		-3.1044E-05	-1.4062E-05	9.0843E-05	-9.1730E-04	4.7483E-04
Surface #	8	9	10	11	12	13
k =	9.0000E+01	-1.2512E+01	-7.2882E+01	2.4659E+00	1.7041E-01	-5.8959E+01
A4 =	-6.3391E-02	1.2476E-03	-9.2357E-03	2.6413E-05	-1.8881E-02	3.5862E-03
A6 =	4.4838E-02	1.0994E-02	3.3671E-03	-3.3010E-03	-1.9121E-03	-8.1695E-03
A8 =	-3.7237E-02	-6.6640E-03	-1.4129E-03	2.9954E-03	2.5340E-03	2.4346E-03
A10 =	1.9025E-02	2.2088E-03	1.0837E-03	-1.4320E-03	-7.9559E-04	-4.4291E-04
A12 =	-5.7209E-03	-4.3328E-04	-2.7080E-04	5.0653E-04	1.5137E-04	4.8920E-05
A14 =	7.8196E-04	4.4802E-05	1.6499E-05	-5.9141E-05	-1.4345E-05	-2.9457E-06
A16 =				-1.7945E-20	5.1916E-07	7.5660E-08

In the 6th embodiment, the equation of the aspheric surface profiles of the aforementioned lens elements is the same as the equation of the 1st embodiment. Also, the definitions of these parameters shown in the following table are the same as those stated in the 1st embodiment with corresponding values for the 6th embodiment, so an explanation in this regard will not be provided again.

Moreover, these parameters can be calculated from Table 11 and Table 12 as the following values and satisfy the following conditions:

6th Embodiment			
f [mm]	3.63	SD/TD	0.56
Fno	2.46	R6/R7	0.08
HFOV [deg.]	60.0	(R5 + R6)/(R5 - R6)	0.16
1/ tan(HFOV)	0.58	(R11 - R12)/(R11 + R12)	-1.00
V2	55.8	(R2 + R11)/(R2 - R11)	-0.33
V4	23.5	R11/Y61	-1.32
T12/CT1	3.28	f/CT2	2.11
BL/T56	0.39	f _g /f _h	0.11
BL/TL	0.07		

In the photographing optical lens system according to the 6th embodiment, when a refractive power of the first lens element 610 is P1, a refractive power of the second lens element 620 is P2, a refractive power of the third lens element 630 is P3, a refractive power of the fourth lens element 640 is P4, a refractive power of the fifth lens element 650 is P5, and a refractive power of the sixth lens element 660 is P6, the following conditions are satisfied: |P3|>|P1|; |P3|>|P2|; |P3|>|P5|; |P3|>|P6|; |P4|>|P1|; |P4|>|P2|; |P4|>|P5|; and |P4|>|P6|.

In the photographing optical lens system according to the 6th embodiment, when an axial distance between the first lens element 610 and the second lens element 620 is T12, an axial distance between the second lens element 620 and the third lens element 630 is T23, an axial distance between the third lens element 630 and the fourth lens element 640 is T34, an axial distance between the fourth lens element 640 and the fifth lens element 650 is T45, and an axial distance between the fifth lens element 650 and the sixth lens element 660 is T56, the following conditions are satisfied: T12>T23; T12>T34; T12>T45; T56>T23; T56>T34; and T56>T45.

7th Embodiment

FIG. 13 is a schematic view of an image capturing apparatus according to the 7th embodiment of the present

disclosure. FIG. 14 shows spherical aberration curves, astigmatic field curves and a distortion curve of the image capturing apparatus according to the 7th embodiment. In FIG. 13, the image capturing apparatus includes a photographing optical lens system (its reference numeral is omitted) and an image sensor 790. The photographing optical lens system includes, in order from an object side to an image side, a first lens element 710, a second lens element 720, an aperture stop 700, a third lens element 730, a fourth lens element 740, a fifth lens element 750, a sixth lens element 760, an IR-cut filter 770 and an image surface 780, wherein the image sensor 790 is disposed on the image surface 780 of the photographing optical lens system. The photographing optical lens system has a total of six lens elements (710-760), and there is an air space between every two lens elements of the first lens element 710, the second lens element 720, the third lens element 730, the fourth lens element 740, the fifth lens element 750 and the sixth lens element 760 that are adjacent to each other.

The first lens element 710 with negative refractive power has an object-side surface 711 being convex in a paraxial region thereof and an image-side surface 712 being concave in a paraxial region thereof. The first lens element 710 is made of a glass material, and has the object-side surface 711 and the image-side surface 712 being both aspheric.

The second lens element 720 with negative refractive power has an object-side surface 721 being concave in a paraxial region thereof and an image-side surface 722 being convex in a paraxial region thereof. The second lens element 720 is made of a plastic material, and has the object-side surface 721 and the image-side surface 722 being both aspheric.

The third lens element 730 with positive refractive power has an object-side surface 731 being convex in a paraxial region thereof and an image-side surface 732 being convex in a paraxial region thereof. The third lens element 730 is made of a plastic material, and has the object-side surface 731 and the image-side surface 732 being both aspheric.

The fourth lens element 740 with negative refractive power has an object-side surface 741 being convex in a paraxial region thereof and an image-side surface 742 being concave in a paraxial region thereof. The fourth lens element 740 is made of a plastic material, and has the object-side surface 741 and the image-side surface 742 being both aspheric.

31

The fifth lens element 750 with positive refractive power has an object-side surface 751 being concave in a paraxial region thereof and an image-side surface 752 being convex in a paraxial region thereof. The fifth lens element 750 is made of a plastic material, and has the object-side surface 751 and the image-side surface 752 being both aspheric.

The sixth lens element 760 with negative refractive power has an object-side surface 761 being concave in a paraxial region thereof and an image-side surface 762 being convex in a paraxial region thereof. The sixth lens element 760 is made of a plastic material, and has the object-side surface 761 and the image-side surface 762 being both aspheric. Furthermore, the object-side surface 761 of the sixth lens element 760 includes at least one inflection point.

The IR-cut filter 770 is made of a glass material and located between the sixth lens element 760 and the image surface 780, and will not affect the focal length of the photographing optical lens system.

The detailed optical data of the 7th embodiment are shown in Table 13 and the aspheric surface data are shown in Table 14 below.

32

In the 7th embodiment, the equation of the aspheric surface profiles of the aforementioned lens elements is the same as the equation of the 1st embodiment. Also, the definitions of these parameters shown in the following table are the same as those stated in the 1st embodiment with corresponding values for the 7th embodiment, so an explanation in this regard will not be provided again.

Moreover, these parameters can be calculated from Table 13 and Table 14 as the following values and satisfy the following conditions:

7th Embodiment				
f [mm]	2.76	SD/TD		0.52
Fno	2.28	R6/R7		0.24
HFOV [deg.]	81.3	(R5 + R6)/(R5 - R6)		-0.06
1/ tan(HFOV)	0.15	(R11 - R12)/(R11 + R12)		-0.76
V2	23.3	(R2 + R11)/(R2 - R11)		-0.41
V4	20.4	R11/Y61		-1.35

TABLE 13

7th Embodiment							
f = 2.76 mm, Fno = 2.28, HFOV = 81.2 deg.							
Surface #		Curvature Radius	Thickness	Material	Index	Abbe #	Focal Length
0	Object	Plano	Infinity				
1	Lens 1	3.199 ASP	0.793	Glass	1.723	38.7	-4.58
2		1.458 ASP	1.796				
3	Lens 2	-7.759 ASP	1.605	Plastic	1.639	23.3	-94.5
4		-9.622 ASP	0.409				
5	Ape. Stop	Plano	-0.222				
6	Lens 3	2.177 ASP	1.223	Plastic	1.544	55.9	2.33
7		-2.436 ASP	0.073				
8	Lens 4	10.366 ASP	0.527	Plastic	1.660	20.4	-4.04
9		2.080 ASP	0.665				
10	Lens 5	-15.212 ASP	0.901	Plastic	1.544	55.9	4.47
11		-2.139 ASP	1.273				
12	Lens 6	-3.518 ASP	0.520	Plastic	1.639	23.3	-6.46
13		-25.305 ASP	0.250				
14	IR-cut filter	Plano	0.210	Glass	1.517	64.2	—
15		Plano	0.534				
16	Image	Plano	—				

Note: Reference wavelength is 587.6 nm (d-line).

TABLE 14

Aspheric Coefficients						
Surface #	1	2	3	4	6	7
k =	-8.1070E-01	-7.8043E-01	-4.0103E+01	2.3127E+01	-1.0560E+01	-1.1868E+00
A4 =	-8.8434E-04	1.4975E-02	-2.3424E-02	-4.0742E-02	5.6205E-02	2.3033E-02
A6 =	-1.5726E-03	-4.2952E-03	4.1914E-03	2.1502E-02	2.0903E-02	-1.4426E-02
A8 =	1.1048E-04	1.6034E-03	-3.4402E-03	-1.2801E-03	-5.9454E-02	1.2880E-02
A10 =	3.7551E-07	-4.4529E-04	1.0492E-03	-3.3110E-03	3.4284E-02	-1.8704E-02
A12 =	-1.8370E-07	2.5238E-06	-8.9426E-05	1.3053E-03	-6.0121E-03	5.2185E-03
Surface #	8	9	10	11	12	13
k =	-6.6819E+01	-9.6589E+00	4.4044E+01	-7.0567E-01	-2.1809E-01	4.7621E+01
A4 =	-5.7099E-02	1.6802E-02	-9.6122E-03	4.1328E-03	-7.0576E-03	-5.8246E-03
A6 =	2.5991E-03	-1.8224E-02	1.3038E-02	5.7632E-03	3.4075E-03	-8.3372E-05
A8 =	-1.9069E-02	1.1045E-05	-2.8455E-03	-4.2321E-04	4.4625E-04	1.0800E-04
A10 =	4.9871E-03	5.2491E-03	3.3041E-04	5.5833E-04	-2.4908E-04	4.5089E-06
A12 =	-2.4297E-04	-2.7748E-03	-9.4089E-05	-1.2208E-04	3.7078E-05	-3.0380E-06
A14 =	-1.9900E-17	5.4299E-04	-2.2713E-17	1.4340E-06	-2.4888E-06	2.6933E-07
A16 =					6.4995E-08	-7.6831E-09

-continued

7th Embodiment			
T12/CT1	2.26	f/CT2	1.72
BL/T56	0.78	f _r /f _f	0.61
BL/TL	0.09		

In the photographing optical lens system according to the 7th embodiment, when a refractive power of the first lens element **710** is P1, a refractive power of the second lens element **720** is P2, a refractive power of the third lens element **730** is P3, a refractive power of the fourth lens element **740** is P4, a refractive power of the fifth lens element **750** is P5, and a refractive power of the sixth lens element **760** is P6, the following conditions are satisfied: |P3|>|P1|; |P3|>|P2|; |P3|>|P5|; |P3|>|P6|; |P4|>|P4|>|P2|; |P4|>|P5|; and |P4|>|P6|.

In the photographing optical lens system according to the 7th embodiment, when an axial distance between the first lens element **710** and the second lens element **720** is T12, an axial distance between the second lens element **720** and the third lens element **730** is T23, an axial distance between the third lens element **730** and the fourth lens element **740** is T34, an axial distance between the fourth lens element **740** and the fifth lens element **750** is T45, and an axial distance between the fifth lens element **750** and the sixth lens element **760** is T56, the following conditions are satisfied: T12>T23; T12>T34; T12>T45; T56>T23; T56>T34; and T56>T45.

8th Embodiment

FIG. 15 is a schematic view of an image capturing apparatus according to the 8th embodiment of the present disclosure. FIG. 16 shows spherical aberration curves, astigmatic field curves and a distortion curve of the image capturing apparatus according to the 8th embodiment. In FIG. 15, the image capturing apparatus includes a photographing optical lens system (its reference numeral is omitted) and an image sensor **890**. The photographing optical lens system includes, in order from an object side to an image side, a first lens element **810**, a second lens element **820**, a third lens element **830**, an aperture stop **800**, a fourth lens element **840**, a fifth lens element **850**, a sixth lens element **860**, an IR-cut filter **870** and an image surface **880**, wherein the image sensor **890** is disposed on the image surface **880** of the photographing optical lens system. The photographing optical lens system has a total of six lens elements (**810-860**), and there is an air space between every two lens elements of the first lens element **810**, the second lens element **820**, the third lens element **830**, the fourth lens

element **840**, the fifth lens element **850** and the sixth lens element **860** that are adjacent to each other.

The first lens element **810** with negative refractive power has an object-side surface **811** being convex in a paraxial region thereof and an image-side surface **812** being concave in a paraxial region thereof. The first lens element **810** is made of a plastic material, and has the object-side surface **811** and the image-side surface **812** being both aspheric.

The second lens element **820** with negative refractive power has an object-side surface **821** being concave in a paraxial region thereof and an image-side surface **822** being convex in a paraxial region thereof. The second lens element **820** is made of a plastic material, and has the object-side surface **821** and the image-side surface **822** being both aspheric.

The third lens element **830** with positive refractive power has an object-side surface **831** being convex in a paraxial region thereof and an image-side surface **832** being convex in a paraxial region thereof. The third lens element **830** is made of a plastic material, and has the object-side surface **831** and the image-side surface **832** being both aspheric.

The fourth lens element **840** with negative refractive power has an object-side surface **841** being convex in a paraxial region thereof and an image-side surface **842** being concave in a paraxial region thereof. The fourth lens element **840** is made of a plastic material, and has the object-side surface **841** and the image-side surface **842** being both aspheric.

The fifth lens element **850** with positive refractive power has an object-side surface **851** being convex in a paraxial region thereof and an image-side surface **852** being convex in a paraxial region thereof. The fifth lens element **850** is made of a plastic material, and has the object-side surface **851** and the image-side surface **852** being both aspheric.

The sixth lens element **860** with negative refractive power has an object-side surface **861** being concave in a paraxial region thereof and an image-side surface **862** being convex in a paraxial region thereof. The sixth lens element **860** is made of a plastic material, and has the object-side surface **861** and the image-side surface **862** being both aspheric. Furthermore, the object-side surface **861** of the sixth lens element **860** includes at least one inflection point.

The IR-cut filter **870** is made of a glass material and located between the sixth lens element **860** and the image surface **880**, and will not affect the focal length of the photographing optical lens system.

The detailed optical data of the 8th embodiment are shown in Table 15 and the aspheric surface data are shown in Table 16 below.

TABLE 15

8th Embodiment							
f = 2.71 mm, Fno = 2.48, HFOV = 76.1 deg.							
Surface #		Curvature Radius	Thickness	Material	Index	Abbe #	Focal Length
0	Object	Plano	Infinity				
1	Lens 1	2.990 ASP	0.969	Plastic	1.544	55.9	-4.01
2		1.117 ASP	2.008				
3	Lens 2	-8.933 ASP	1.378	Plastic	1.639	23.3	-54.91
4		-12.707 ASP	0.100				
5	Lens 3	2.257 ASP	1.106	Plastic	1.544	55.9	2.47
6		-2.749 ASP	-0.079				
7	Ape. Stop	Plano	0.366				
8	Lens 4	10.204 ASP	0.480	Plastic	1.660	20.4	-5.65

TABLE 15-continued

8th Embodiment							
f = 2.71 mm, Fno = 2.48, HFOV = 76.1 deg.							
Surface #		Curvature Radius	Thickness	Material	Index	Abbe #	Focal Length
9		2.680 ASP	0.481				
10	Lens 5	14.014 ASP	0.940	Plastic	1.544	55.9	5.03
11		-3.317 ASP	1.066				
12	Lens 6	-2.961 ASP	0.877	Plastic	1.639	23.3	-9.44
13		-6.485 ASP	0.250				
14	IR-cut filter	Plano	0.210	Glass	1.517	64.2	—
15		Plano	0.602				
16	Image	Plano	—				

Note: Reference wavelength is 587.6 nm (d-line).

TABLE 16

Aspheric Coefficients						
Surface #	1	2	3	4	5	6
k =	-1.0588E+00	-8.1257E-01	-4.6198E+01	-1.4948E+01	-5.4531E-01	-1.0335E+00
A4 =	-8.8434E-04	1.4975E-02	-1.9759E-02	-2.1492E-02	-2.1103E-02	1.9215E-02
A6 =	-1.5726E-03	-4.2952E-03	5.4733E-03	2.6173E-02	4.7372E-02	-3.7339E-02
A8 =	1.1048E-04	1.6034E-03	-3.1337E-03	-8.5159E-03	-4.6904E-02	4.5299E-02
A10 =	3.7551E-07	-4.4529E-04	9.6903E-04	-1.2224E-04	2.7012E-02	-2.5749E-02
A12 =	-1.8370E-07	2.5238E-06	-8.9426E-05	1.3053E-03	-6.0121E-03	5.2185E-03
Surface #	8	9	10	11	12	13
k =	-9.0000E+01	-1.1422E+01	4.5602E+01	-5.1371E-01	3.6804E-01	-3.8244E+00
A4 =	-4.0870E-02	1.9842E-02	-1.5516E-02	4.7904E-03	-1.6820E-02	-3.5957E-03
A6 =	2.9183E-02	-4.7811E-04	1.0807E-02	3.1473E-03	3.5491E-03	-1.0185E-03
A8 =	-4.6473E-02	-8.4828E-03	-2.8079E-03	-8.1411E-04	6.1363E-04	9.6735E-05
A10 =	1.7584E-02	7.2875E-03	4.9193E-04	5.4626E-04	-2.1887E-04	1.0464E-05
A12 =	-2.4297E-04	-2.7748E-03	-9.4089E-05	-1.2208E-04	3.7078E-05	-3.0380E-06
A14 =	-9.0607E-20	5.4299E-04	-1.0342E-19	1.4340E-06	-2.4888E-06	2.6933E-07
A16 =					6.4995E-08	-7.6831E-09

In the 8th embodiment, the equation of the aspheric surface profiles of the aforementioned lens elements is the same as the equation of the 1st embodiment. Also, the definitions of these parameters shown in the following table are the same as those stated in the 1st embodiment with corresponding values for the 8th embodiment, so an explanation in this regard will not be provided again.

Moreover, these parameters can be calculated from Table 15 and Table 16 as the following values and satisfy the following conditions:

8th Embodiment			
f [mm]	2.71	SD/TD	0.43
Fno	2.48	R6/R7	0.27
HFOV [deg.]	76.1	(R5 + R6)/(R5 - R6)	-0.10
1/tan(HFOV)	0.25	(R11 - R12)/(R11 + R12)	-0.37
V2	23.3	(R2 + R11)/(R2 - R11)	-0.45
V4	20.4	R11/Y61	-1.38
T12/CT1	2.07	f/CT2	1.97
BL/T56	1.00	fr/ff	7.04
BL/TL	0.10		

In the photographing optical lens system according to the 8th embodiment, when an axial distance between the first lens element **810** and the second lens element **820** is T12, an axial distance between the second lens element **820** and the third lens element **830** is T23, an axial distance between the third lens element **830** and the fourth lens element **840** is T34, an axial distance between the fourth lens element **840**

and the fifth lens element **850** is T45, and an axial distance between the fifth lens element **850** and the sixth lens element **860** is T56, the following conditions are satisfied: T12>T23; T12>T34; T12>T45; T56>T23; T56>T34; and T56>T45.

9th Embodiment

FIG. 17 is a schematic view of an image capturing apparatus according to the 9th embodiment of the present disclosure. FIG. 18 shows spherical aberration curves, astigmatic field curves and a distortion curve of the image capturing apparatus according to the 9th embodiment. In FIG. 17, the image capturing apparatus includes a photographing optical lens system (its reference numeral is omitted) and an image sensor **990**. The photographing optical lens system includes, in order from an object side to an image side, a first lens element **910**, a second lens element **920**, an aperture stop **900**, a third lens element **930**, a fourth lens element **940**, a fifth lens element **950**, a sixth lens element **960**, an IR-cut filter **970** and an image surface **980**, wherein the image sensor **990** is disposed on the image surface **980** of the photographing optical lens system. The photographing optical lens system has a total of six lens elements (**910-960**), and there is an air space between every two lens elements of the first lens element **910**, the second lens element **920**, the third lens element **930**, the fourth lens element **940**, the fifth lens element **950** and the sixth lens element **960** that are adjacent to each other.

The first lens element **910** with negative refractive power has an object-side surface **911** being convex in a paraxial

region thereof and an image-side surface 912 being concave in a paraxial region thereof. The first lens element 910 is made of a glass material, and has the object-side surface 911 and the image-side surface 912 being both aspheric.

The second lens element 920 with positive refractive power has an object-side surface 921 being concave in a paraxial region thereof and an image-side surface 922 being convex in a paraxial region thereof. The second lens element 920 is made of a plastic material, and has the object-side surface 921 and the image-side surface 922 being both aspheric.

The third lens element 930 with positive refractive power has an object-side surface 931 being convex in a paraxial region thereof and an image-side surface 932 being convex in a paraxial region thereof. The third lens element 930 is made of a plastic material, and has the object-side surface 931 and the image-side surface 932 being both aspheric.

The fourth lens element 940 with negative refractive power has an object-side surface 941 being concave in a paraxial region thereof and an image-side surface 942 being concave in a paraxial region thereof. The fourth lens element 940 is made of a plastic material, and has the object-side surface 941 and the image-side surface 942 being both aspheric.

The fifth lens element 950 with positive refractive power has an object-side surface 951 being convex in a paraxial region thereof and an image-side surface 952 being convex in a paraxial region thereof. The fifth lens element 950 is made of a plastic material, and has the object-side surface 951 and the image-side surface 952 being both aspheric.

The sixth lens element 960 with negative refractive power has an object-side surface 961 being concave in a paraxial region thereof and an image-side surface 962 being convex in a paraxial region thereof. The sixth lens element 960 is made of a plastic material, and has the object-side surface 961 and the image-side surface 962 being both aspheric. Furthermore, the object-side surface 961 and the image-side surface 962 of the sixth lens element 960 include at least one inflection point.

The IR-cut filter 970 is made of a glass material and located between the sixth lens element 960 and the image surface 980, and will not affect the focal length of the photographing optical lens system.

The detailed optical data of the 9th embodiment are shown in Table 17 and the aspheric surface data are shown in Table 18 below.

TABLE 17

9th Embodiment							
f = 3.16 mm, Fno = 2.26, HFOV = 62.0 deg.							
Surface #		Curvature Radius	Thickness	Material	Index	Abbe #	Focal Length
0	Object	Plano	Infinity				
1	Lens 1	2.826 ASP	0.831	Glass	1.589	61.3	-6.16
2		1.416 ASP	2.364				
3	Lens 2	-10.532 ASP	2.085	Plastic	1.535	55.8	13.04
4		-4.485 ASP	0.174				
5	Ape. Stop	Plano	-0.031				
6	Lens 3	3.161 ASP	1.541	Plastic	1.535	55.8	2.79
7		-2.341 ASP	0.100				
8	Lens 4	-19.491 ASP	0.373	Plastic	1.639	23.5	-3.26
9		2.351 ASP	0.312				
10	Lens 5	6.903 ASP	0.749	Plastic	1.544	55.9	6.17
11		-6.271 ASP	2.024				
12	Lens 6	-3.797 ASP	0.408	Plastic	1.544	55.9	-9.21
13		-16.329 ASP	0.300				
14	IR-cut filter	Plano	0.300	Glass	1.517	64.2	—
15		Plano	0.179				
16	Image	Plano	—				

Note: Reference wavelength is 587.6 nm (d-line).

TABLE 18

Aspheric Coefficients						
Surface #	1	2	3	4	6	7
k =	-5.1327E-01	-6.5808E-01	-8.0865E+01	-7.3659E+00	8.2795E-02	-2.3205E-01
A4 =	-3.3043E-03	3.9373E-03	-1.8012E-02	-1.4348E-02	-4.9603E-03	2.4401E-02
A6 =	-1.0482E-03	-1.8097E-03	2.2715E-03	5.4299E-03	3.9790E-03	-2.4728E-02
A8 =	7.6135E-05	-3.3951E-04	-1.3105E-03	-1.3660E-03	-5.6149E-03	1.3341E-02
A10 =	-2.0813E-06	1.9819E-04	2.8849E-04	4.0792E-04	2.9776E-03	-4.2796E-03
A12 =		-3.1044E-05	-1.4062E-05	9.0843E-05	-9.1730E-04	4.7483E-04
Surface #	8	9	10	11	12	13
k =	8.0490E+01	-1.2050E+01	-6.2075E+01	5.1661E+00	6.8595E-02	-5.8959E+01
A4 =	-7.1756E-02	2.3918E-03	-9.6219E-03	-7.8700E-03	-1.4925E-02	7.7724E-03
A6 =	4.5101E-02	1.0992E-02	4.1840E-03	-1.7179E-03	-2.9748E-03	-9.4586E-03
A8 =	-3.6619E-02	-6.5148E-03	-1.8877E-03	2.7855E-03	2.4978E-03	2.7429E-03
A10 =	1.9121E-02	2.2433E-03	1.0844E-03	-1.5035E-03	-7.8989E-04	-5.3504E-04

TABLE 18-continued

Aspheric Coefficients						
A12 =	-5.7209E-03	-4.3328E-04	-2.7080E-04	5.0653E-04	1.5137E-04	6.6059E-05
A14 =	7.8196E-04	4.4802E-05	1.6499E-05	-5.9141E-05	-1.4345E-05	-4.4728E-06
A16 =				-2.1293E-18	5.1916E-07	1.2889E-07

In the 9th embodiment, the equation of the aspheric surface profiles of the aforementioned lens elements is the same as the equation of the 1st embodiment. Also, the definitions of these parameters shown in the following table are the same as those stated in the 1st embodiment with corresponding values for the 9th embodiment, so an explanation in this regard will not be provided again.

Moreover, these parameters can be calculated from Table 17 and Table 18 as the following values and satisfy the following conditions:

9th Embodiment			
f [mm]	3.16	SD/TD	0.50
Fno	2.26	R6/R7	0.12
HFOV [deg.]	62.0	(R5 + R6)/(R5 - R6)	0.15
1/ tan(HFOV)	0.53	(R11 - R12)/(R11 + R12)	-0.62
V2	55.8	(R2 + R11)/(R2 - R11)	-0.46
V4	23.5	R11/Y61	-1.40
T12/CT1	2.84	f/CT2	1.52
BL/T56	0.38	f _r /f _t	0.17
BL/TL	0.07		

In the photographing optical lens system according to the 9th embodiment, when a refractive power of the first lens element **910** is P1, a refractive power of the second lens element **920** is P2, a refractive power of the third lens element **930** is P3, a refractive power of the fourth lens element **940** is P4, a refractive power of the fifth lens element **950** is P5, and a refractive power of the sixth lens element **960** is P6, the following conditions are satisfied: |P3|>|P1|; |P3|>|P2|; |P3|>|P5|; |P3|>|P6|; |P4|>|P1|; |P4|>|P2|; |P4|>|P5|; and |P4|>|P6|.

In the photographing optical lens system according to the 9th embodiment, when an axial distance between the first lens element **910** and the second lens element **920** is T12, an axial distance between the second lens element **920** and the third lens element **930** is T23, an axial distance between the third lens element **930** and the fourth lens element **940** is T34, an axial distance between the fourth lens element **940** and the fifth lens element **950** is T45, and an axial distance between the fifth lens element **950** and the sixth lens element **960** is T56, the following conditions are satisfied: T12>T23; T12>T34; T12>T45; T56>T23; T56>T34; and T56>T45.

10th Embodiment

FIG. 19 is a schematic view of an image capturing apparatus according to the 10th embodiment of the present disclosure. FIG. 20 shows spherical aberration curves, astigmatic field curves and a distortion curve of the image capturing apparatus according to the 10th embodiment. In FIG. 19, the image capturing apparatus includes a photographing optical lens system (its reference numeral is omitted) and an image sensor **1090**. The photographing optical lens system includes, in order from an object side to an image side, a first lens element **1010**, a second lens element **1020**, an aperture stop **1000**, a third lens element **1030**, a fourth lens element **1040**, a fifth lens element **1050**, a sixth

lens element **1060**, an IR-cut filter **1070** and an image surface **1080**, wherein the image sensor **1090** is disposed on the image surface **1080** of the photographing optical lens system. The photographing optical lens system has a total of six lens elements (**1010-1060**), and there is an air space between every two lens elements of the first lens element **1010**, the second lens element **1020**, the third lens element **1030**, the fourth lens element **1040**, the fifth lens element **1050** and the sixth lens element **1060** that are adjacent to each other.

The first lens element **1010** with negative refractive power has an object-side surface **1011** being concave in a paraxial region thereof and an image-side surface **1012** being concave in a paraxial region thereof. The first lens element **1010** is made of a plastic material, and has the object-side surface **1011** and the image-side surface **1012** being both aspheric.

The second lens element **1020** with positive refractive power has an object-side surface **1021** being concave in a paraxial region thereof and an image-side surface **1022** being convex in a paraxial region thereof. The second lens element **1020** is made of a plastic material, and has the object-side surface **1021** and the image-side surface **1022** being both aspheric.

The third lens element **1030** with positive refractive power has an object-side surface **1031** being convex in a paraxial region thereof and an image-side surface **1032** being convex in a paraxial region thereof. The third lens element **1030** is made of a plastic material, and has the object-side surface **1031** and the image-side surface **1032** being both aspheric.

The fourth lens element **1040** with negative refractive power has an object-side surface **1041** being concave in a paraxial region thereof and an image-side surface **1042** being concave in a paraxial region thereof. The fourth lens element **1040** is made of a plastic material, and has the object-side surface **1041** and the image-side surface **1042** being both aspheric.

The fifth lens element **1050** with positive refractive power has an object-side surface **1051** being convex in a paraxial region thereof and an image-side surface **1052** being convex in a paraxial region thereof. The fifth lens element **1050** is made of a plastic material, and has the object-side surface **1051** and the image-side surface **1052** being both aspheric.

The sixth lens element **1060** with negative refractive power has an object-side surface **1061** being concave in a paraxial region thereof and an image-side surface **1062** being convex in a paraxial region thereof. The sixth lens element **1060** is made of a plastic material, and has the object-side surface **1061** and the image-side surface **1062** being both aspheric. Furthermore, the object-side surface **1061** and the image-side surface **1062** of the sixth lens element **1060** include at least one inflection point.

The IR-cut filter **1070** is made of a glass material and located between the sixth lens element **1060** and the image surface **1080**, and will not affect the focal length of the photographing optical lens system.

The detailed optical data of the 10th embodiment are shown in Table 19 and the aspheric surface data are shown in Table 20 below.

TABLE 19

10th Embodiment							
f = 3.19 mm, Fno = 2.00, HFOV = 63.9 deg.							
Surface #		Curvature Radius	Thickness	Material	Index	Abbe #	Focal Length
0	Object	Plano	Infinity				
1	Lens 1	-11.802 ASP	1.350	Plastic	1.544	55.9	-6.28
2		5.001 ASP	1.327				
3	Lens 2	-15.334 ASP	2.291	Plastic	1.535	55.8	9.98
4		-4.165 ASP	0.290				
5	Ape. Stop	Plano	-0.235				
6	Lens 3	3.176 ASP	1.955	Plastic	1.535	55.8	2.94
7		-2.439 ASP	0.116				
8	Lens 4	-25.848 ASP	0.330	Plastic	1.639	23.5	-3.25
9		2.269 ASP	0.237				
10	Lens 5	8.309 ASP	0.858	Plastic	1.544	55.9	5.28
11		-4.231 ASP	1.393				
12	Lens 6	-2.851 ASP	0.644	Plastic	1.544	55.9	-5.43
13		-90.909 ASP	0.300				
14	IR-cut filter	Plano	0.300	Glass	1.517	64.2	—
15		Plano	0.193				
16	Image	Plano	—				

Note: Reference wavelength is 587.6 nm (d-line).

TABLE 20

Aspheric Coefficients						
Surface #	1	2	3	4	6	7
k =	-9.0000E+01	3.8818E+00	-8.6169E+01	-1.0158E+01	2.3244E+00	-2.4153E-01
A4 =	2.9986E-03	1.0768E-02	-1.4369E-02	-1.5324E-02	-7.8916E-03	2.3407E-02
A6 =	-1.5807E-04	-4.6818E-04	2.2228E-03	4.7693E-03	1.7045E-04	-2.1975E-02
A8 =	2.9079E-06	-2.9345E-04	-9.8648E-04	-1.2934E-03	-4.8011E-03	1.1307E-02
A10 =	2.7667E-08	1.4966E-04	1.7414E-04	4.2815E-04	2.6818E-03	-3.8413E-03
A12 =		-3.1016E-05	-4.3543E-06	-3.4366E-05	-9.1730E-04	4.7483E-04
Surface #	8	9	10	11	12	13
k =	9.0000E+01	-9.8171E+00	1.7258E+01	3.1299E+00	-1.1760E+00	-5.8959E+01
A4 =	-8.3963E-02	4.6774E-04	-4.8826E-03	9.5679E-03	4.5899E-03	3.0719E-02
A6 =	4.6168E-02	8.5951E-03	3.7109E-03	-3.2387E-03	-1.0300E-02	-2.3261E-02
A8 =	-3.6714E-02	-5.7679E-03	-2.4942E-03	3.0514E-03	2.9744E-03	7.7721E-02
A10 =	1.8675E-02	2.1242E-03	1.2207E-03	-1.2793E-03	-7.4322E-04	-1.6283E-03
A12 =	-5.7209E-03	-4.3328E-04	-2.7080E-04	5.0653E-04	1.5144E-04	2.0246E-04
A14 =	7.8196E-04	4.4802E-05	1.6499E-05	-5.9141E-05	-1.4345E-05	-1.3490E-05
A16 =				-3.4735E-18	5.1916E-07	3.7130E-07

In the 10th embodiment, the equation of the aspheric surface profiles of the aforementioned lens elements is the same as the equation of the 1st embodiment. Also, the definitions of these parameters shown in the following table are the same as those stated in the 1st embodiment with corresponding values for the 10th embodiment, so an explanation in this regard will not be provided again.

Moreover, these parameters can be calculated from Table 19 and Table 20 as the following values and satisfy the following conditions:

10th Embodiment			
f [mm]	3.19	SD/TD	0.50
Fno	2.00	R6/R7	0.09
HFOV [deg.]	63.9	(R5 + R6)/(R5 - R6)	0.13
1/tan(HFOV)	0.49	(R11 - R12)/(R11 + R12)	-0.94
V2	55.8	(R2 + R11)/(R2 - R11)	0.27
V4	23.5	R11/Y61	-1.26
T12/CT1	0.98	f/CT2	1.39
BL/T56	0.57	f/#	0.02
BL/TL	0.07		

In the photographing optical lens system according to the 10th embodiment, when a refractive power of the first lens element **1010** is P1, a refractive power of the second lens element **1020** is P2, a refractive power of the third lens element **1030** is P3, a refractive power of the fourth lens element **1040** is P4, a refractive power of the fifth lens element **1050** is P5, and a refractive power of the sixth lens element **1060** is P6, the following conditions are satisfied: $|P3| > |P1|$; $|P3| > |P2|$; $|P3| > |P5|$; $|P3| > |P6|$; $|P4| > |P1|$; $|P4| > |P2|$; $|P4| > |P5|$; and $|P4| > |P6|$.

In the photographing optical lens system according to the 10th embodiment, when an axial distance between the first lens element **1010** and the second lens element **1020** is T12, an axial distance between the second lens element **1020** and the third lens element **1030** is T23, an axial distance between the third lens element **1030** and the fourth lens element **1040** is T34, an axial distance between the fourth lens element **1040** and the fifth lens element **1050** is T45, and an axial distance between the fifth lens element **1050** and the sixth lens element **1060** is T56, the following conditions are satisfied: $T12 > T23$; $T12 > T34$; $T12 > T45$; $T56 > T23$; $T56 > T34$; and $T56 > T45$.

43

11th Embodiment

FIG. 22 is a schematic view of an electronic device 10 according to the 11th embodiment of the present disclosure. The electronic device 10 of the 11th embodiment is a smart phone, wherein the electronic device 10 includes an image capturing apparatus 11. The image capturing apparatus 11 includes a photographing optical lens system (not shown herein) according to the present disclosure and an image sensor (not shown herein), wherein the image sensor is disposed on an image surface of the photographing optical lens system.

12th Embodiment

FIG. 23 is a schematic view of an electronic device 20 according to the 12th embodiment of the present disclosure. The electronic device 20 of the 12th embodiment is a tablet personal computer, wherein the electronic device 20 includes an image capturing apparatus 21. The image capturing apparatus 21 includes a photographing optical lens system (not shown herein) according to the present disclosure and an image sensor (not shown herein), wherein the image sensor is disposed on an image surface of the photographing optical lens system.

13th Embodiment

FIG. 24 is a schematic view of an electronic device 30 according to the 13th embodiment of the present disclosure. The electronic device 30 of the 13th embodiment is a head-mounted display (HMD), wherein the electronic device 30 includes an image capturing apparatus 31. The image capturing apparatus 31 includes a photographing optical lens system (not shown herein) according to the present disclosure and an image sensor (not shown herein), wherein the image sensor is disposed on an image surface of the photographing optical lens system.

The foregoing description, for purpose of explanation, has been described with reference to specific embodiments. It is to be noted that Tables 1-20 show different data of the different embodiments; however, the data of the different embodiments are obtained from experiments. The embodiments were chosen and described in order to best explain the principles of the disclosure and its practical applications, to thereby enable others skilled in the art to best utilize the disclosure and various embodiments with various modifications as are suited to the particular use contemplated. The embodiments depicted above and the appended drawings are exemplary and are not intended to be exhaustive or to limit the scope of the present disclosure to the precise forms disclosed. Many modifications and variations are possible in view of the above teachings.

What is claimed is:

1. A photographing optical lens system comprising, in order from an object side to an image side:

- a first lens element having negative refractive power;
- a second lens element having an image-side surface being convex in a paraxial region thereof;
- a third lens element having positive refractive power;
- a fourth lens element having negative refractive power;
- a fifth lens element; and
- a sixth lens element with negative refractive power having an object-side surface being concave in a paraxial region thereof and an image-side surface being planar or convex in a paraxial region thereof;

44

wherein the photographing optical lens system has a total of six lens elements, a curvature radius of an object-side surface of the third lens element is R5, a curvature radius of an image-side surface of the third lens element is R6, a curvature radius of an object-side surface of the fourth lens element is R7, a curvature radius of the object-side surface of the sixth lens element is R11, a curvature radius of the image-side surface of the sixth lens element is R12, and the following conditions are satisfied:

$$-1.0 \leq (R11 - R12) / (R11 + R12) < 0;$$

$$-1.50 < (R5 + R6) / (R5 - R6) < 3.50; \text{ and}$$

$$|R6 / R7| < 0.85.$$

2. The photographing optical lens system of claim 1, wherein the curvature radius of the object-side surface of the third lens element is R5, the curvature radius of the image-side surface of the third lens element is R6, and the following condition is satisfied:

$$-1.0 < (R5 + R6) / (R5 - R6) < 1.0.$$

3. The photographing optical lens system of claim 1, wherein the curvature radius of the object-side surface of the third lens element is R5, the curvature radius of the image-side surface of the third lens element is R6, and the following condition is satisfied:

$$-0.45 < (R5 + R6) / (R5 - R6) < 0.45.$$

4. The photographing optical lens system of claim 1, further comprising:

a stop disposed between the second lens element and the third lens element, wherein an axial distance between the stop and the image-side surface of the sixth lens element is SD, an axial distance between an object-side surface of the first lens element and the image-side surface of the sixth lens element is TD, and the following condition is satisfied:

$$0.40 < SD / TD < 0.60.$$

5. The photographing optical lens system of claim 4, wherein the second lens element has an object-side surface being concave in a paraxial region thereof.

6. The photographing optical lens system of claim 4, wherein a composite focal length of lens elements between an imaged object and the stop is ff, a composite focal length of lens elements between the stop and an image surface is fr, and the following condition is satisfied:

$$|fr / ff| < 0.67.$$

7. The photographing optical lens system of claim 1, wherein an axial distance between the image-side surface of the sixth lens element and an image surface is BL, an axial distance between an object-side surface of the first lens element and the image surface is TL, and the following condition is satisfied:

$$0 < BL / TL < 0.15.$$

8. The photographing optical lens system of claim 1, wherein there is an air space between every two lens elements of the first lens element, the second lens element, the third lens element, the fourth lens element, the fifth lens element and the sixth lens element that are adjacent to each other, a focal length of the photographing optical lens system is f, a central thickness of the second lens element is CT2, and the following condition is satisfied:

$$0 < f / CT2 < 3.0.$$

45

9. The photographing optical lens system of claim 1, wherein an Abbe number of the second lens element is V2, and the following condition is satisfied:

$$V2 < 25.0.$$

10. The photographing optical lens system of claim 1, wherein a refractive power of the first lens element is P1, a refractive power of the second lens element is P2, a refractive power of the third lens element is P3, a refractive power of the fourth lens element is P4, a refractive power of the fifth lens element is P5, a refractive power of the sixth lens element is P6, and the following conditions are satisfied:

$$|P3| > |P1|;$$

$$|P3| > |P2|;$$

$$|P3| > |P5|;$$

$$|P3| > |P6|;$$

$$|P4| > |P1|;$$

$$|P4| > |P2|;$$

$$|P4| > |P5|; \text{ and}$$

$$|P4| > |P6|.$$

11. The photographing optical lens system of claim 1, wherein an axial distance between the first lens element and the second lens element is T12, an axial distance between the second lens element and the third lens element is T23, an axial distance between the third lens element and the fourth lens element is T34, an axial distance between the fourth lens element and the fifth lens element is T45, an axial distance between the fifth lens element and the sixth lens element is T56, and the following conditions are satisfied:

$$T12 > T23;$$

$$T12 > T34;$$

$$T12 > T45;$$

$$T56 > T23;$$

$$T56 > T34; \text{ and}$$

$$T56 > T45.$$

12. The photographing optical lens system of claim 1, wherein at least one of the object-side surface and the image-side surface of the sixth lens element comprises at least one inflection point, the curvature radius of the object-side surface of the sixth lens element is R11, a vertical distance between a maximum effective diameter position on the object-side surface of the sixth lens element and an optical axis is Y61, and the following condition is satisfied:

$$-1.50 < R11/Y61 < -0.50.$$

13. An image capturing apparatus, comprising: the photographing optical lens system of claim 1; and an image sensor disposed on an image surface of the photographing optical lens system.

14. An electronic device, comprising: the image capturing apparatus of claim 13.

15. A photographing optical lens system comprising, in order from an object side to an image side:

a first lens element having negative refractive power; a second lens element having an image-side surface being convex in a paraxial region thereof;

46

a third lens element having positive refractive power; a fourth lens element having negative refractive power; a fifth lens element; and

a sixth lens element with negative refractive power having an object-side surface being concave in a paraxial region thereof and an image-side surface being planar or convex in a paraxial region thereof;

wherein the photographing optical lens system has a total of six lens elements, a curvature radius of the object-side surface of the sixth lens element is R11, a curvature radius of the image-side surface of the sixth lens element is R12, an axial distance between the first lens element and the second lens element is T12, an axial distance between the fifth lens element and the sixth lens element is T56, a central thickness of the first lens element is CT1, an axial distance between the image-side surface of the sixth lens element and an image surface is BL, and the following conditions are satisfied:

$$-1.0 \leq (R11 - R12) / (R11 + R12) < 0;$$

$$0.90 < T12 / CT1 < 9.0; \text{ and}$$

$$0 < BL / T56 < 1.65.$$

16. The photographing optical lens system of claim 15, wherein the first lens element has an object-side surface being convex in a paraxial region thereof and an image-side surface being concave in a paraxial region thereof.

17. The photographing optical lens system of claim 15, wherein a curvature radius of an image-side surface of the first lens element is R2, the curvature radius of the object-side surface of the sixth lens element is R11, and the following condition is satisfied:

$$-1.0 < (R2 + R11) / (R2 - R11) < 1.0.$$

18. The photographing optical lens system of claim 15, wherein a curvature radius of an image-side surface of the first lens element is R2, the curvature radius of the object-side surface of the sixth lens element is R11, and the following condition is satisfied:

$$-0.60 < (R2 + R11) / (R2 - R11) < 0.50.$$

19. The photographing optical lens system of claim 15, further comprising:

a stop, wherein a composite focal length of lens elements between an imaged object and the stop is f_i , a composite focal length of lens elements between the stop and the image surface is f_r , and the following condition is satisfied:

$$|f_r / f_i| < 0.67.$$

20. The photographing optical lens system of claim 15, wherein an Abbe number of the fourth lens element is V4, and the following condition is satisfied:

$$V4 < 25.0.$$

21. The photographing optical lens system of claim 15, wherein a refractive power of the first lens element is P1, a refractive power of the second lens element is P2, a refractive power of the third lens element is P3, a refractive power of the fourth lens element is P4, a refractive power of the fifth lens element is P5, a refractive power of the sixth lens element is P6, and the following conditions are satisfied:

$$|P3| > |P1|;$$

$$|P3| > |P2|;$$

$|P3|>|P5|;$
 $|P3|>|P6|;$
 $|P4|>|P1|;$
 $|P4|>|P2|;$
 $|P4|>|P5|;$ and
 $|P4|>|P6|.$

22. A photographing optical lens system comprising, in order from an object side to an image side:

- a first lens element having negative refractive power;
- a second lens element having an object-side surface being concave in a paraxial region thereof and an image-side surface being convex in a paraxial region thereof;
- a third lens element;
- a fourth lens element having an image-side surface being concave in a paraxial region thereof;
- a fifth lens element; and
- a sixth lens element with negative refractive power having an object-side surface being concave in a paraxial region thereof and an image-side surface being planar or convex in a paraxial region thereof;

wherein the photographing optical lens system has a total of six lens elements, a curvature radius of the object-side surface of the sixth lens element is R11, a curvature radius of the image-side surface of the sixth lens element is R12, and the following condition is satisfied:

$$-1.0 \leq (R11 - R12) / (R11 + R12) < 0.$$

23. The photographing optical lens system of claim 22, wherein an axial distance between the image-side surface of the sixth lens element and an image surface is BL, an axial distance between an object-side surface of the first lens element and the image surface is TL, and the following condition is satisfied:

$$0 < BL/TL < 0.20.$$

24. The photographing optical lens system of claim 22, wherein a half of a maximum field of view of the photographing optical lens system is HFOV, and the following condition is satisfied:

$$|1/\tan(HFOV)| < 0.80.$$

25. The photographing optical lens system of claim 22, wherein an axial distance between the first lens element and

the second lens element is T12, an axial distance between the second lens element and the third lens element is T23, an axial distance between the third lens element and the fourth lens element is T34, an axial distance between the fourth lens element and the fifth lens element is T45, an axial distance between the fifth lens element and the sixth lens element is T56, and the following conditions are satisfied:

$$T12 > T23;$$

$$T12 > T34;$$

$$T12 > T45;$$

$$T56 > T23;$$

$$T56 > T34; \text{ and}$$

$$T56 > T45.$$

26. The photographing optical lens system of claim 22, wherein a focal length of the photographing optical lens system is f, a central thickness of the second lens element is CT2, and the following condition is satisfied:

$$0 < f/CT2 < 4.0.$$

27. The photographing optical lens system of claim 22, wherein at least one of the object-side surface and the image-side surface of the sixth lens element comprises at least one inflection point, the curvature radius of the object-side surface of the sixth lens element is R11, a vertical distance between a maximum effective diameter position on the object-side surface of the sixth lens element and an optical axis is Y61, and the following condition is satisfied:

$$-1.85 < R11/Y61 < -0.50.$$

28. The photographing optical lens system of claim 22, wherein there is an air space between every two lens elements of the first lens element, the second lens element, the third lens element, the fourth lens element, the fifth lens element and the sixth lens element that are adjacent to each other.

29. An image capturing apparatus, comprising: the photographing optical lens system of claim 22; and an image sensor disposed on an image surface of the photographing optical lens system.

30. An electronic device, comprising: the image capturing apparatus of claim 29.

* * * * *