



US009304295B2

(12) **United States Patent**  
**Huang**

(10) **Patent No.:** **US 9,304,295 B2**

(45) **Date of Patent:** **Apr. 5, 2016**

(54) **OPTICAL IMAGING LENS ASSEMBLY,  
IMAGE CAPTURING DEVICE AND MOBILE  
TERMINAL**

(52) **U.S. Cl.**  
CPC ..... *G02B 13/0045* (2013.01); *H04N 5/2254*  
(2013.01); *G02B 9/62* (2013.01)

(71) Applicant: **LARGAN PRECISION CO., LTD.**,  
Taichung (TW)

(58) **Field of Classification Search**  
USPC ..... 359/642-830  
See application file for complete search history.

(72) Inventor: **Hsin-Hsuan Huang**, Taichung (TW)

(56) **References Cited**

(73) Assignee: **LARGAN PRECISION CO., LTD.**,  
Taichung (TW)

**FOREIGN PATENT DOCUMENTS**

(\* ) Notice: Subject to any disclaimer, the term of this  
patent is extended or adjusted under 35  
U.S.C. 154(b) by 82 days.

TW M471594 U 2/2014  
WO 2014013676 A1 1/2014  
WO 2014013677 A1 1/2014

*Primary Examiner* — Mahidere Sahle

(74) *Attorney, Agent, or Firm* — CKC & Partners Co., Ltd.

(21) Appl. No.: **14/228,266**

(57) **ABSTRACT**

(22) Filed: **Mar. 28, 2014**

An optical imaging lens assembly includes, in order from an object side to an image side, a first lens element, a second lens element, a third lens element, a fourth lens element, a fifth lens element, and a sixth lens element. The first lens element has negative refractive power. The second lens element has positive refractive power. The third lens element has refractive power. The fourth lens element with refractive power has an object-side surface being concave in a paraxial region thereof. The fifth lens element with refractive power has an object-side surface being convex in a paraxial region thereof and an image-side surface being concave in a paraxial region thereof. The sixth lens element with refractive power has an image-side surface being concave in a paraxial region thereof. The optical imaging lens assembly has a total of six lens elements with refractive power.

(65) **Prior Publication Data**

US 2015/0241659 A1 Aug. 27, 2015

(30) **Foreign Application Priority Data**

Feb. 24, 2014 (TW) ..... 103106081 A

(51) **Int. Cl.**

*G02B 3/02* (2006.01)  
*G02B 13/18* (2006.01)  
*G02B 13/00* (2006.01)  
*H04N 5/225* (2006.01)  
*G02B 9/62* (2006.01)

**25 Claims, 16 Drawing Sheets**

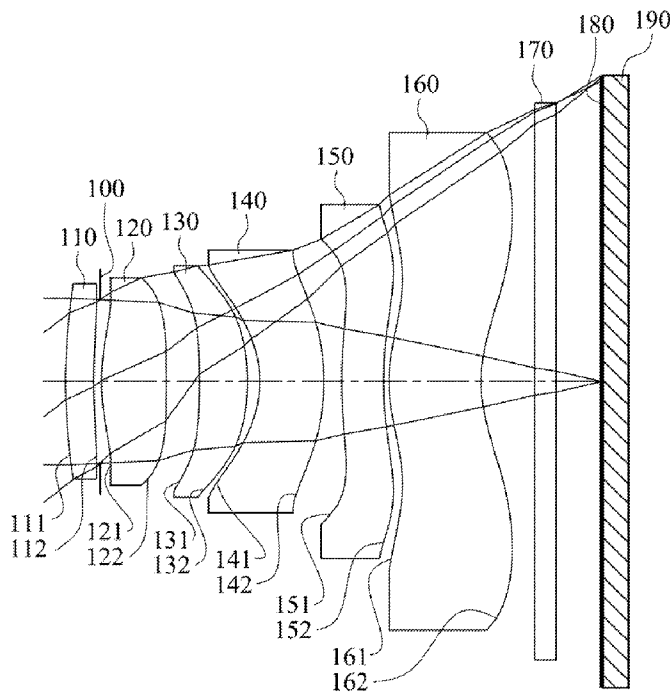

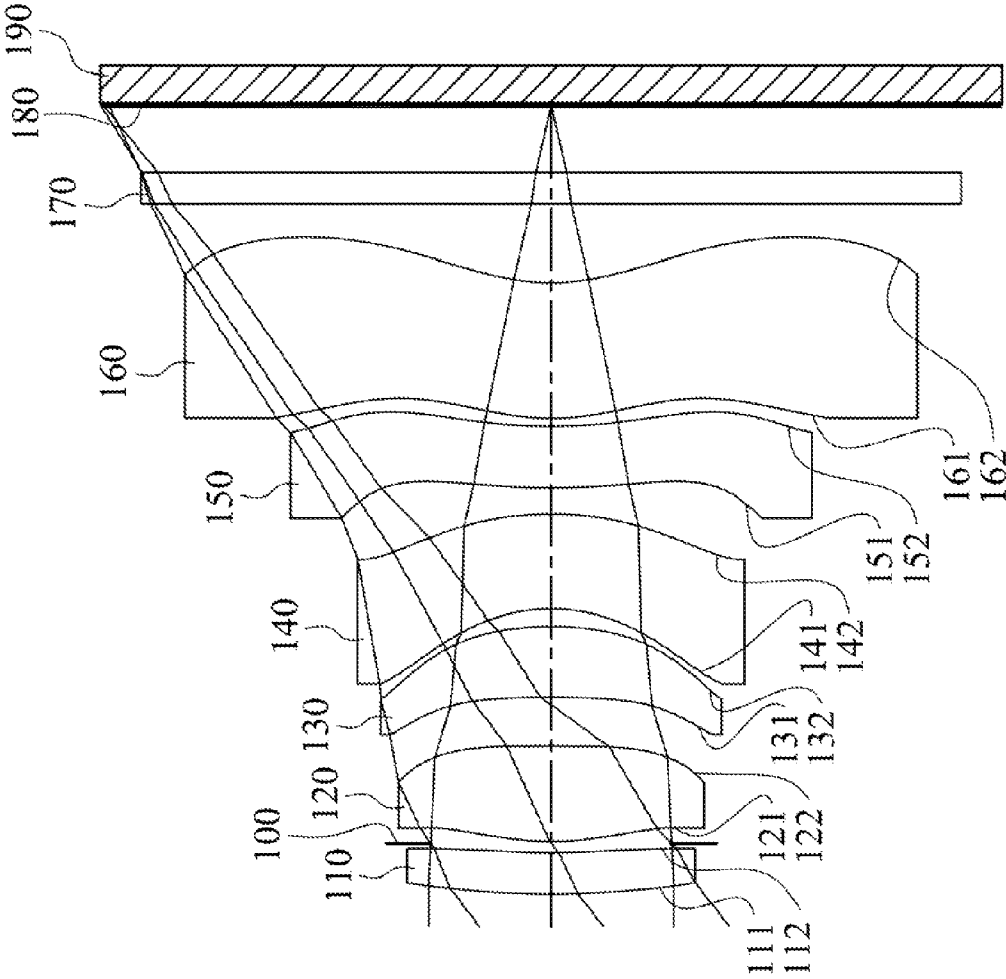

Fig. 1

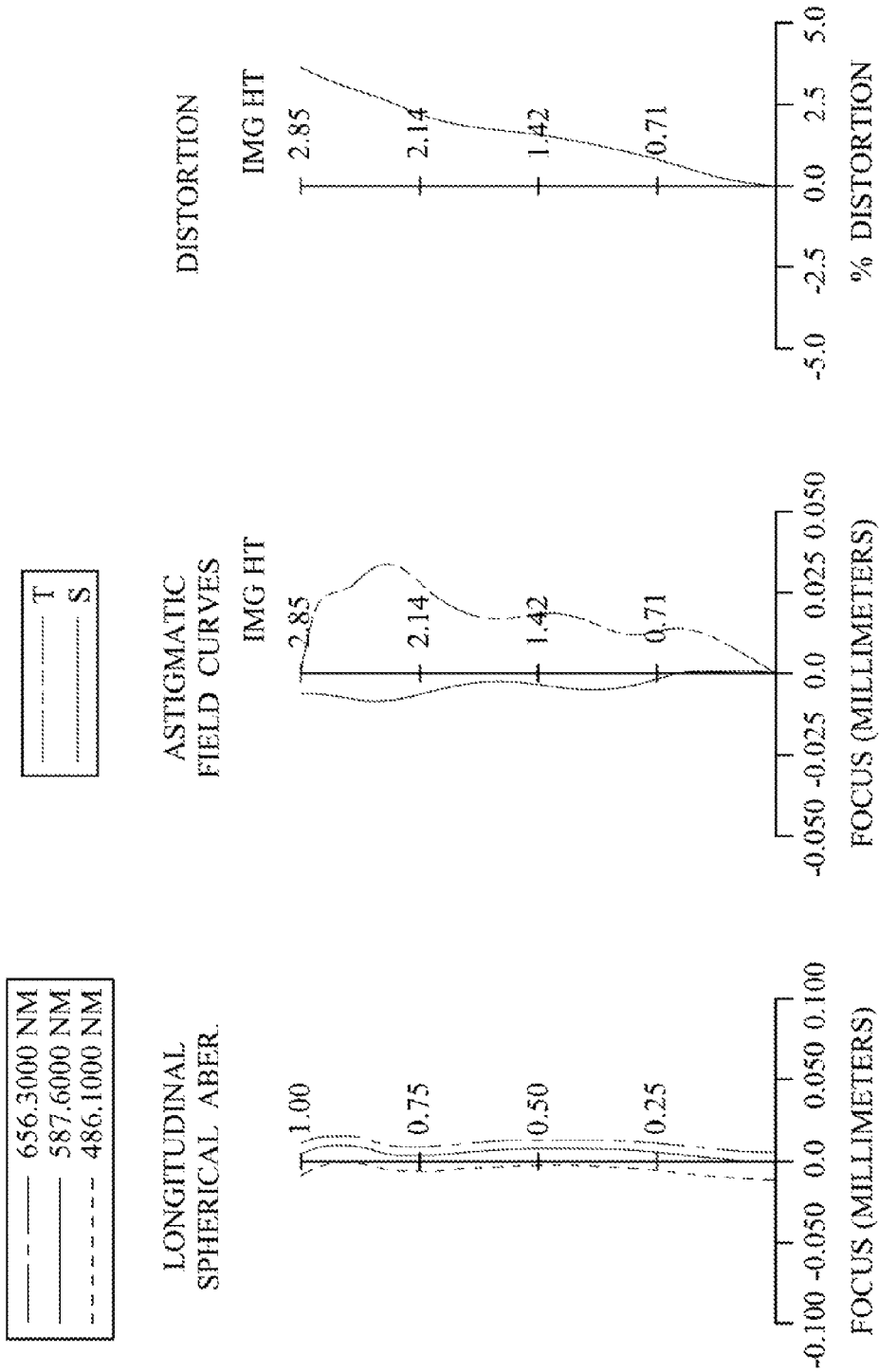

Fig. 2

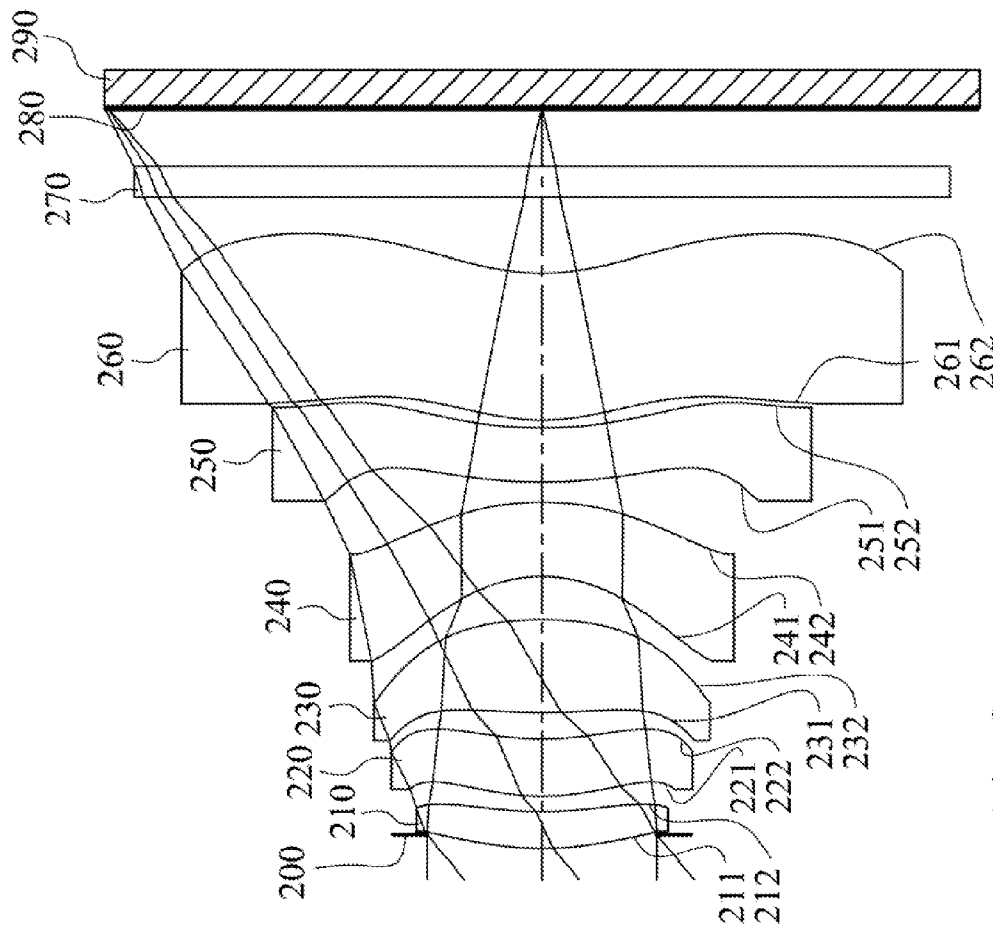

Fig. 3

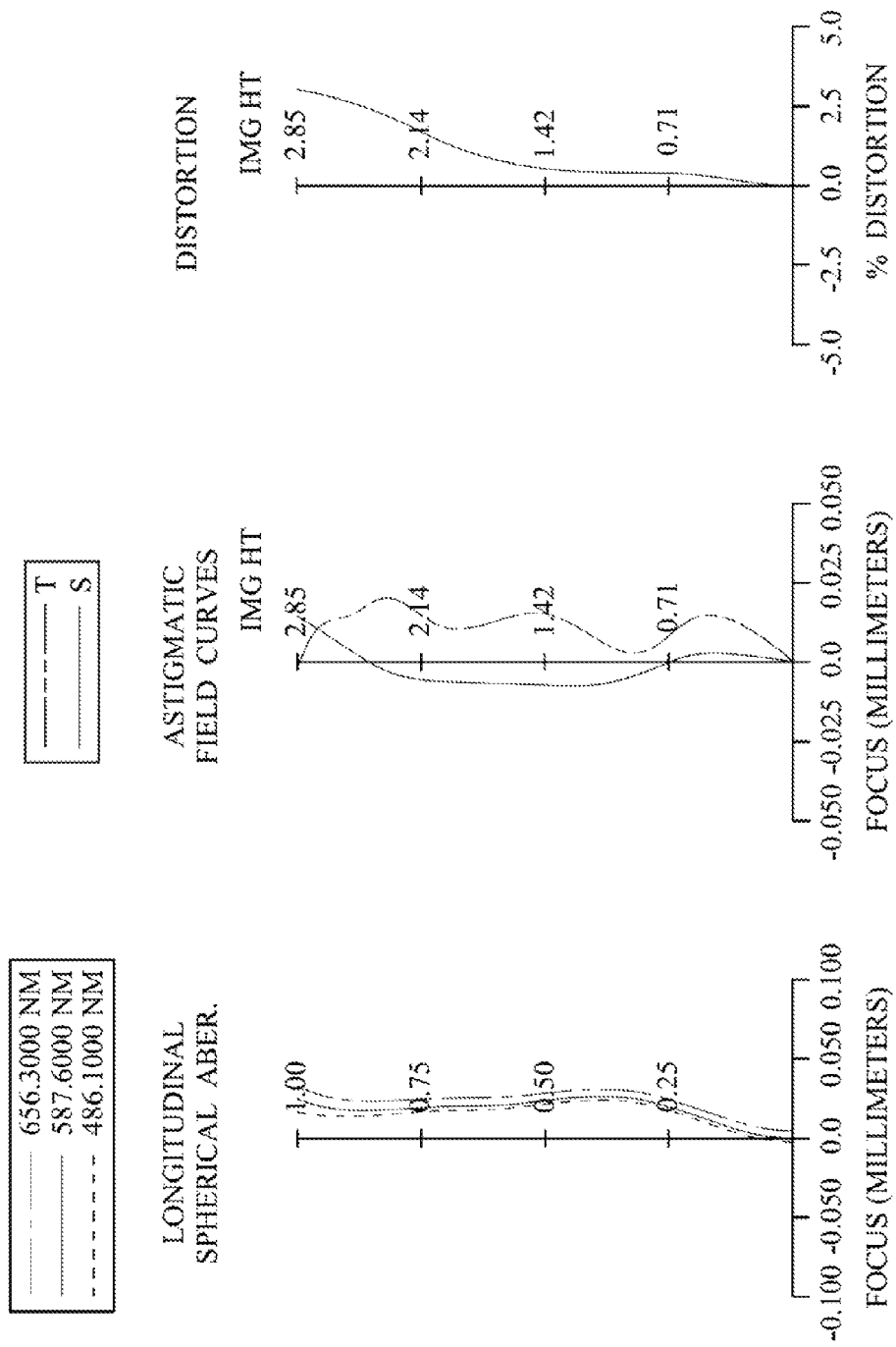

Fig. 4

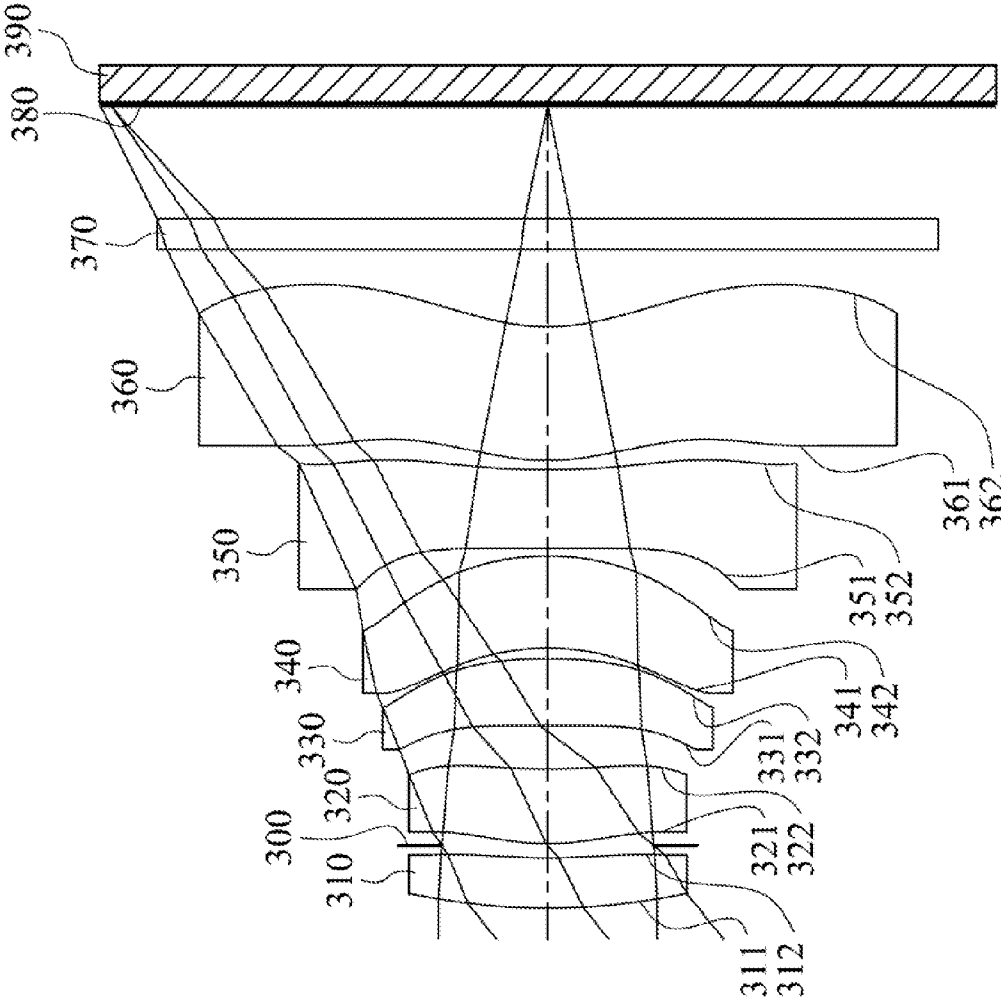

Fig. 5

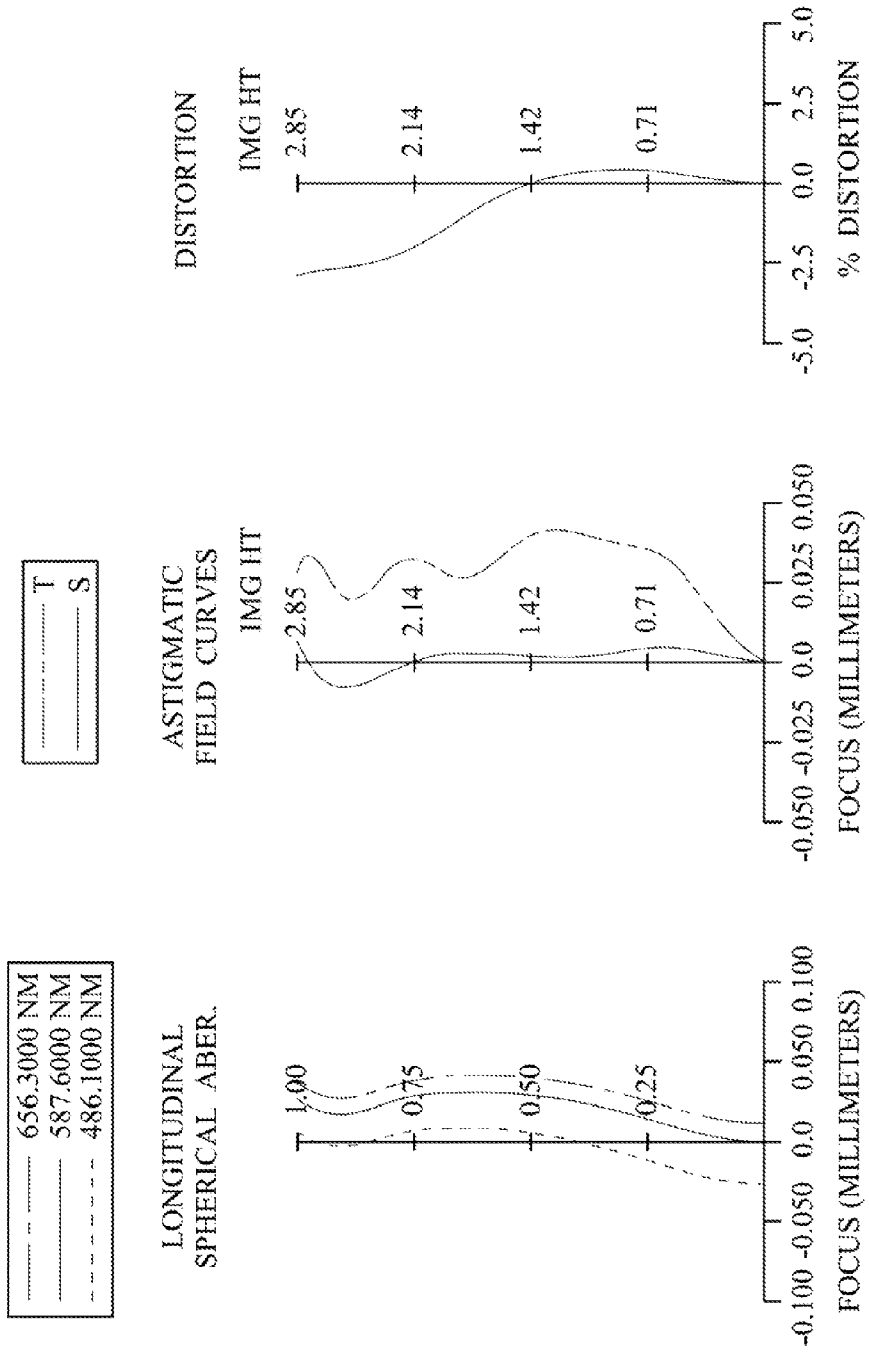

Fig. 6

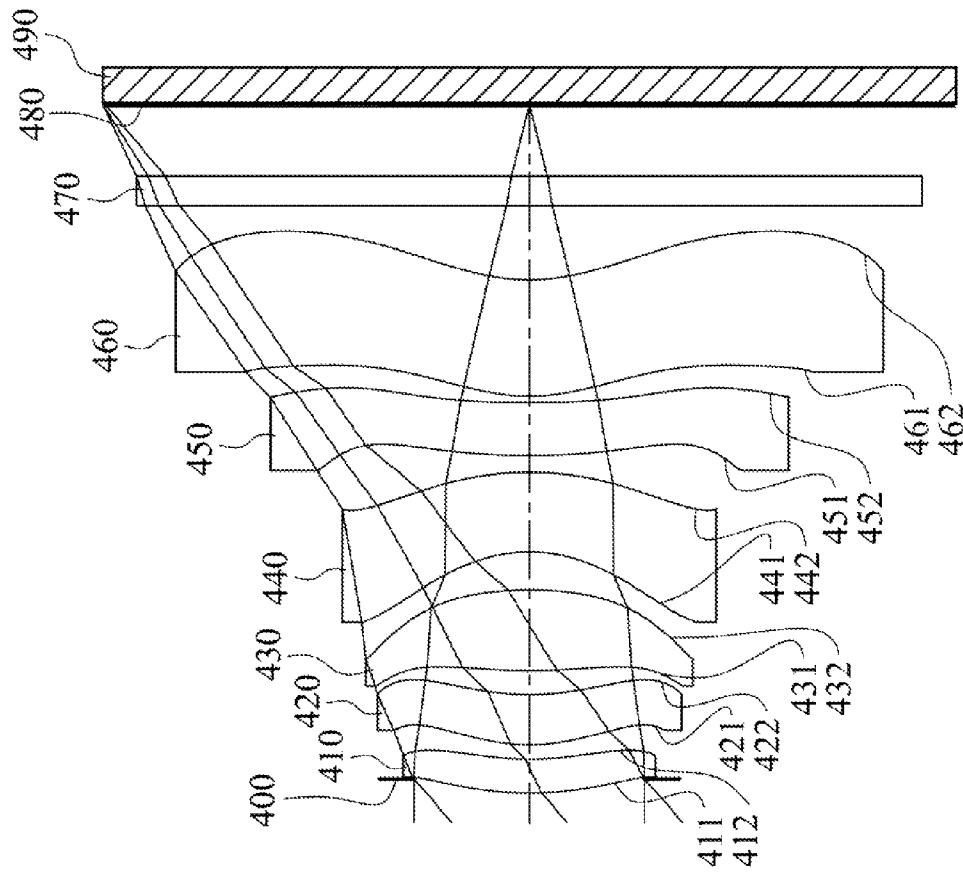

Fig. 7

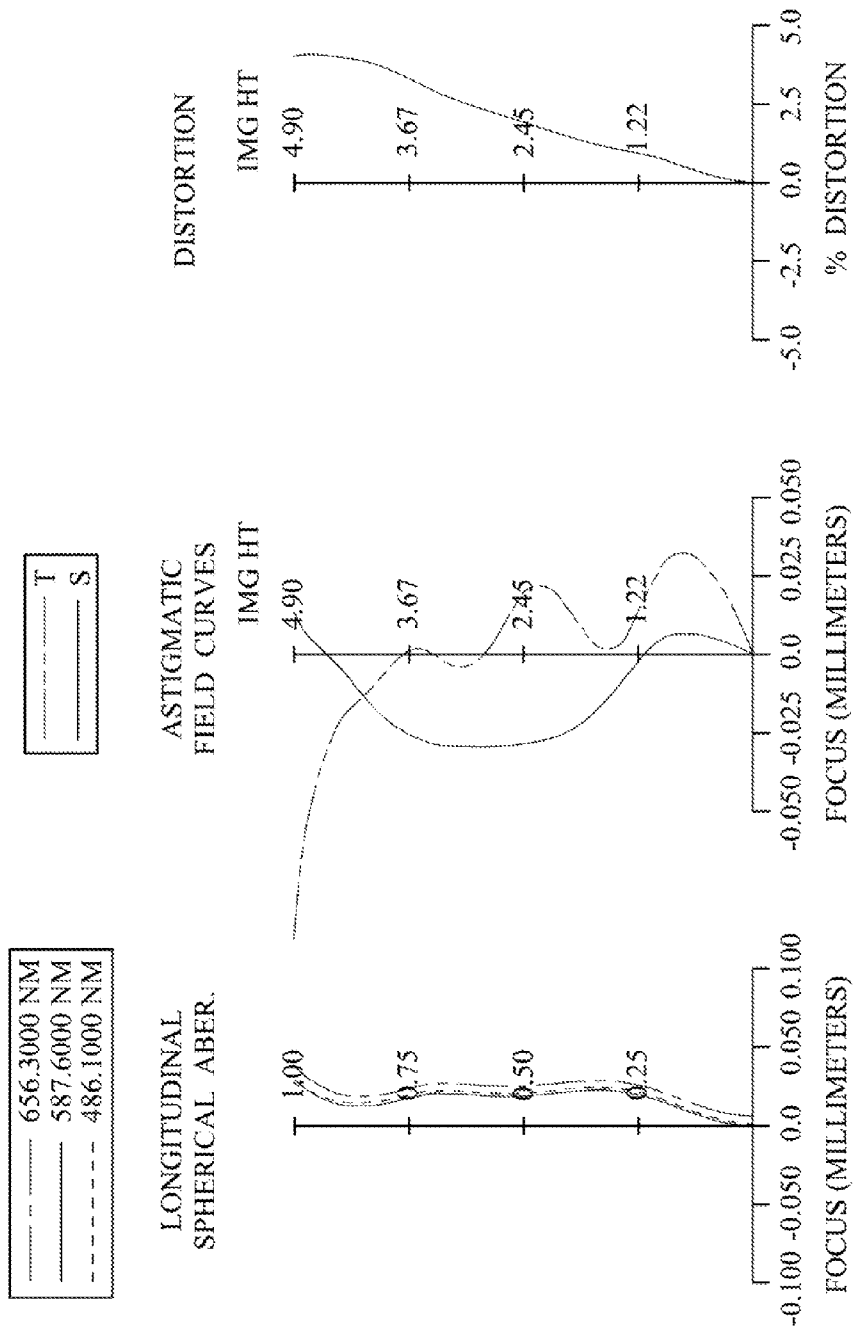

Fig. 8

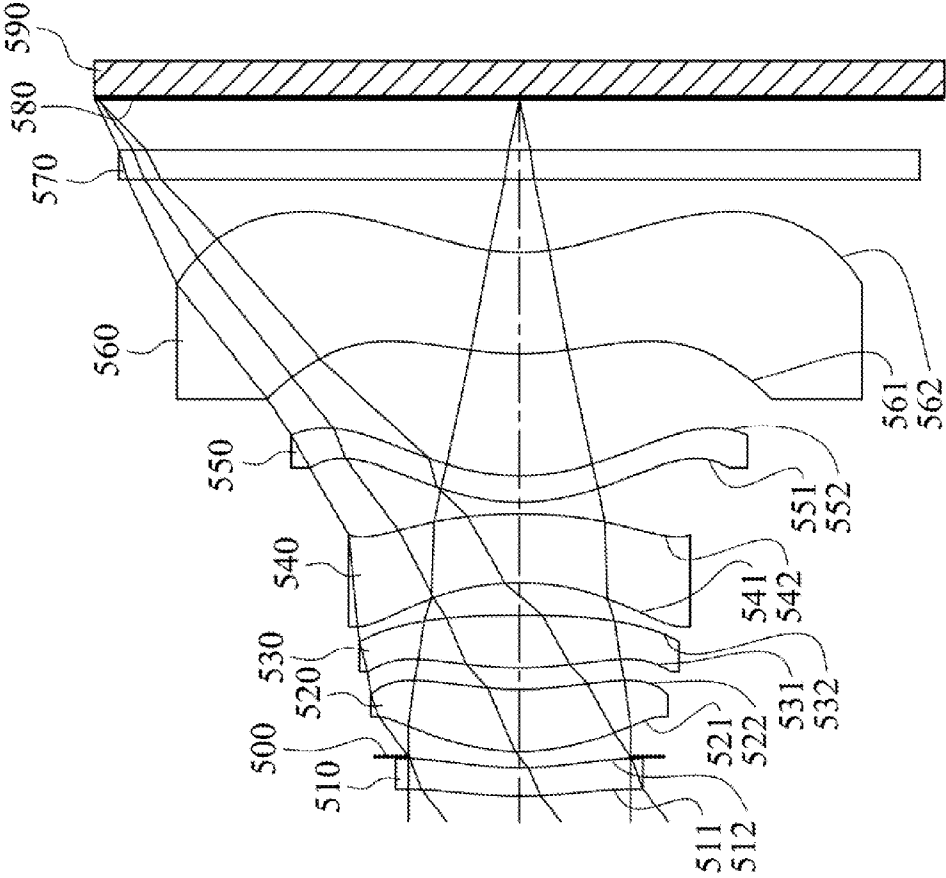

Fig. 9

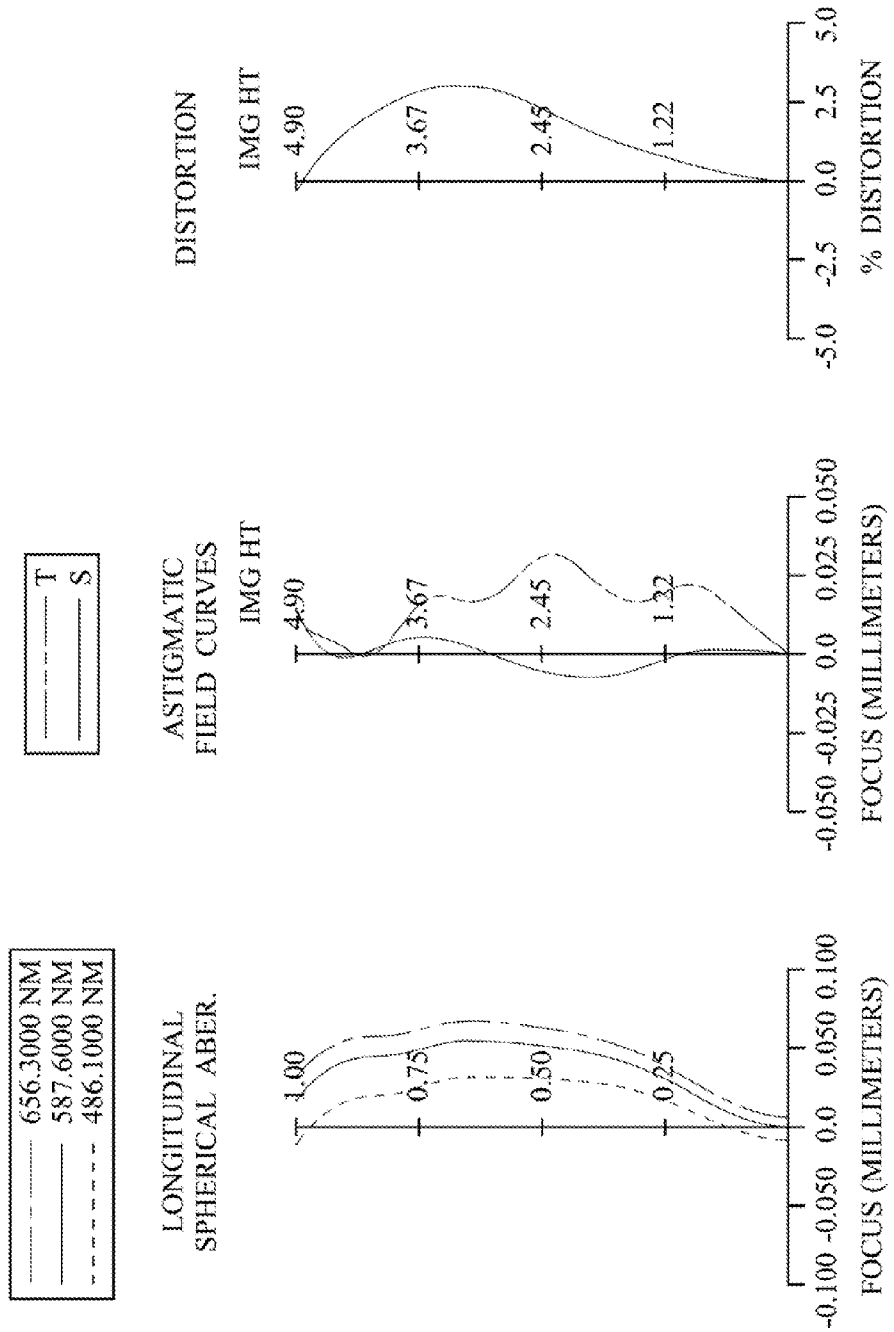

Fig. 10

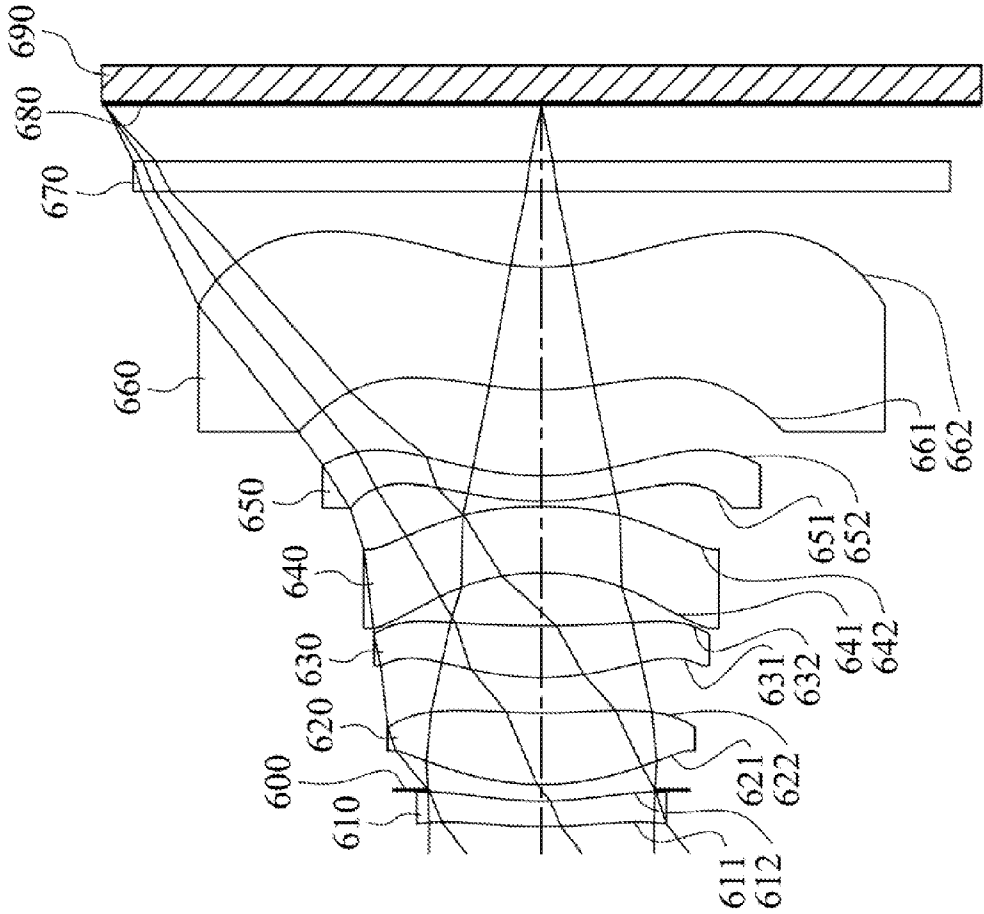

Fig. 11

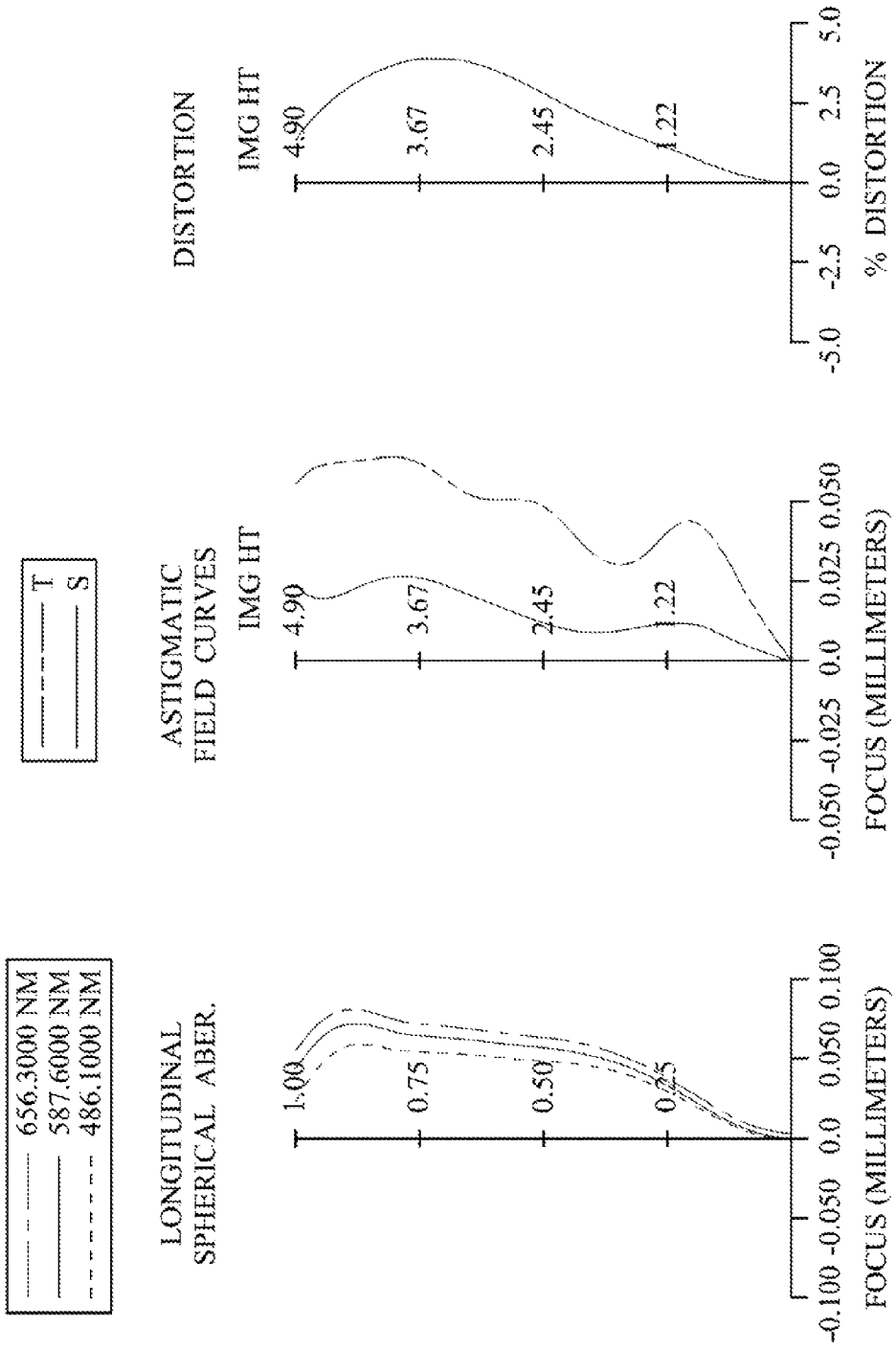

Fig. 12

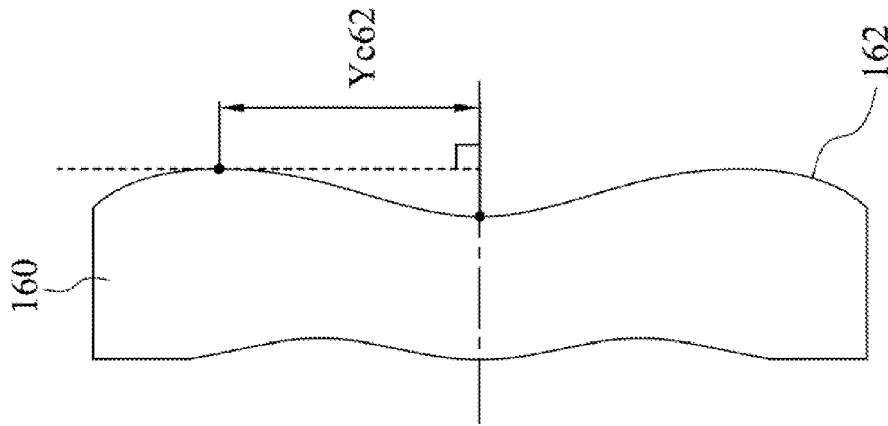

Fig. 14

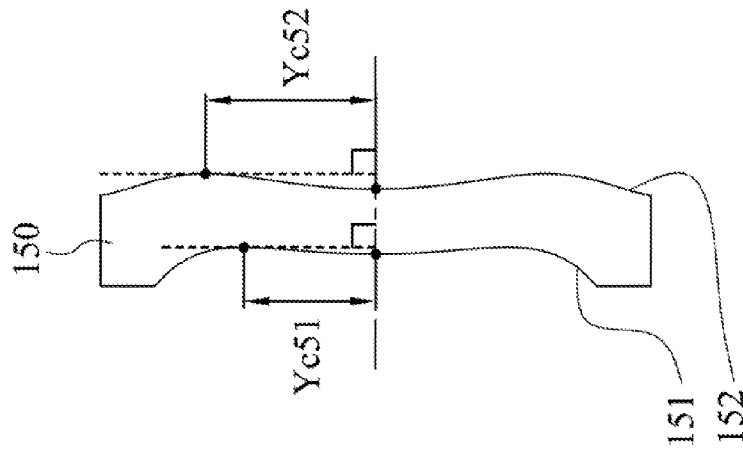

Fig. 13

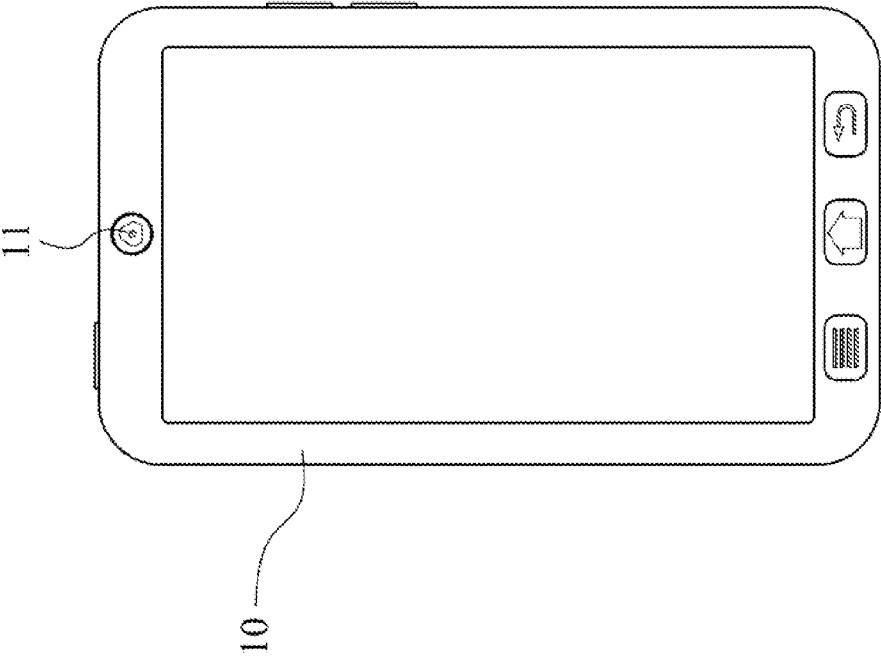

Fig. 15

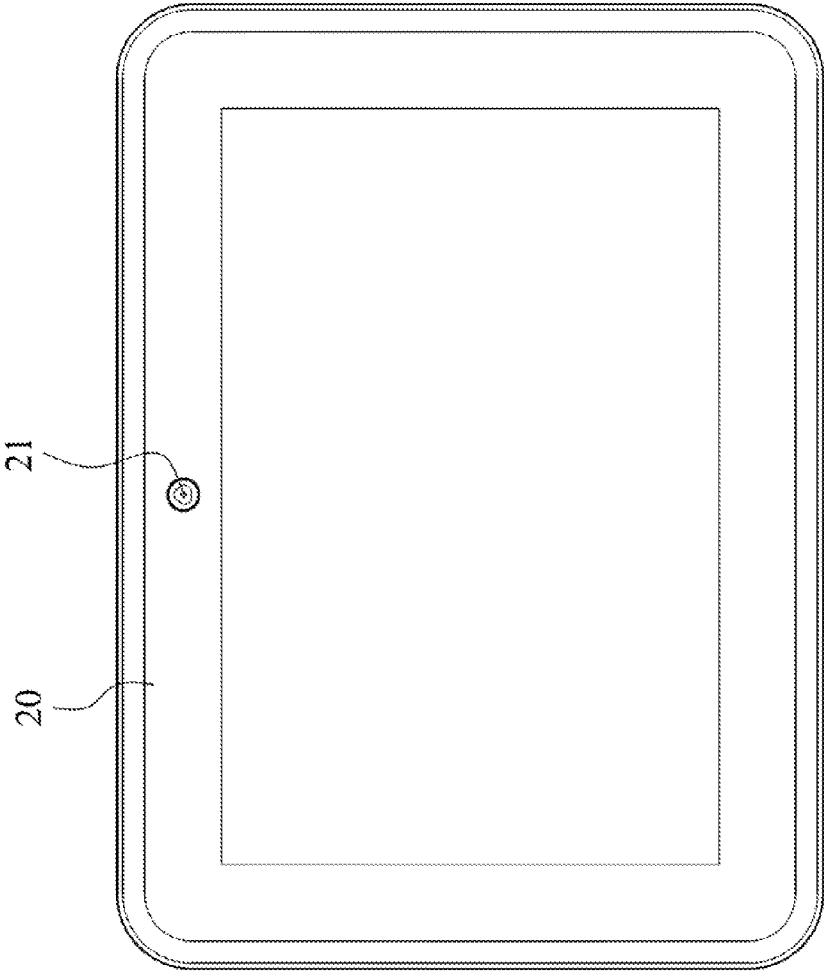

Fig. 16

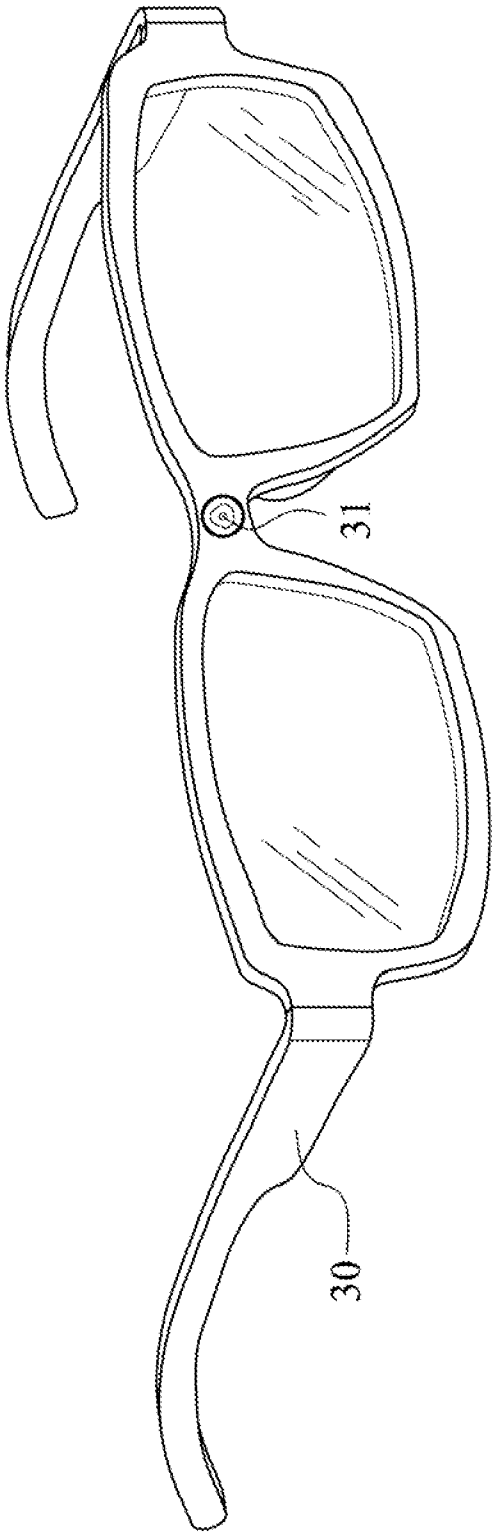

Fig. 17

1

# OPTICAL IMAGING LENS ASSEMBLY, IMAGE CAPTURING DEVICE AND MOBILE TERMINAL

## RELATED APPLICATIONS

This application claims priority to Taiwan Application Serial Number 103106081, filed Feb. 24, 2014, which is incorporated by reference herein in its entirety.

## BACKGROUND

### 1. Technical Field

The present disclosure relates to an optical imaging lens assembly, an image capturing device and mobile terminals. More particularly, the present disclosure relates to a compact optical imaging lens assembly and an image capturing device applicable to mobile terminals.

### 2. Description of Related Art

In recent years, with the popularity of mobile terminals having camera functionalities, the demand of miniaturized optical systems has been increasing. The sensor of a conventional optical system typically a CCD (Charge-Coupled Device) or a CMOS (Complementary Metal-Oxide-Semiconductor) sensor. As the advanced semiconductor manufacturing technologies have allowed the pixel size of sensors to be reduced and compact optical systems have gradually evolved toward the field of higher megapixels, there is an increasing demand for compact optical systems featuring better image quality.

A conventional optical system employed in a portable electronic product mainly adopts a four-element lens structure or a five-element lens structure. Due to the popularity of mobile terminals with high-end specifications, such as smart phones, tablet personal computers and wearable apparatus, the requirements for high resolution and image quality of present compact optical systems increase significantly. However, the conventional optical systems cannot satisfy these requirements of the compact optical systems.

Other conventional compact optical systems with six-element lens structure enhance image quality and resolution. However, the surface shape and refractive power of the lens elements is not favorable for reducing the total track length of the optical system while obtaining more of the image scene. It is thereby not favorable for keeping the optical system compact.

## SUMMARY

According to one aspect of the present disclosure, an optical imaging lens assembly includes, in order from an object side to an image side, a first lens element, a second lens element, a third lens element, a fourth lens element, a fifth lens element, and a sixth lens element. The first lens element has negative refractive power. The second lens element has positive refractive power. The third lens element has refractive power. The fourth lens element with refractive power has an object-side surface being concave in a paraxial region thereof. The fifth lens element with refractive power has an object-side surface being convex in a paraxial region thereof and an image-side surface being concave in a paraxial region thereof, wherein both of the object-side surface and the image-side surface of the fifth lens element are aspheric. The sixth lens element with refractive power has an image-side surface being concave in a paraxial region thereof, wherein both of an object-side surface and the image-side surface of the sixth lens element are aspheric, and the image-side sur-

2

face of the sixth lens element has at least one inflection point. The optical imaging lens assembly has a total of six lens elements with refractive power. When a focal length of the first lens element is  $f_1$ , a focal length of the second lens element is  $f_2$ , a focal length of the optical imaging lens assembly is  $f$ , and a focal length of the fifth lens element is  $f_5$ , the following conditions are satisfied:

$$0 < (f_1 + f_2) / (f_1 - f_2) < 1.0; \text{ and}$$

$$f / f_5 < 0.55.$$

According to another aspect of the present disclosure, an optical imaging lens assembly includes, in order from an object side to an image side, a first lens element, a second lens element, a third lens element, a fourth lens element, a fifth lens element, and a sixth lens element. The first lens element with negative refractive power has an object-side surface being convex in a paraxial region thereof and an image-side surface being concave in a paraxial region thereof. The second lens element has positive refractive power. The third lens element has refractive power. The fourth lens element has refractive power. The fifth lens element with refractive power has an object-side surface being convex in a paraxial region thereof and an image-side surface being concave in a paraxial region thereof, wherein both of the object-side surface and the image-side surface of the fifth lens element are aspheric. The sixth lens element with refractive power has an image-side surface being concave in a paraxial region thereof, wherein both of an object-side surface and the image-side surface of the sixth lens element are aspheric, and the image-side surface of the sixth lens element has at least one inflection point. The optical imaging lens assembly has a total of six lens elements with refractive power. When a focal length of the first lens element is  $f_1$ , a focal length of the second lens element is  $f_2$ , a focal length of the optical imaging lens assembly is  $f$ , and a focal length of the fifth lens element is  $f_5$ , the following conditions are satisfied:

$$0 < (f_1 + f_2) / (f_1 - f_2) < 1.0; \text{ and}$$

$$f / f_5 < 0.55.$$

According to still another aspect of the present disclosure, an optical imaging lens assembly includes, in order from an object side to an image side, a first lens element, a second lens element, a third lens element, a fourth lens element, a fifth lens element, and a sixth lens element. The first lens element has negative refractive power. The second lens element has positive refractive power. The third lens element has refractive power. The fourth lens element has refractive power. The fifth lens element with refractive power has an object-side surface being convex in a paraxial region thereof and an image-side surface being concave in a paraxial region thereof, wherein both of the object-side surface and the image-side surface of the fifth lens element are aspheric, and at least one of the object-side surface and the image-side surface of the fifth lens element has at least one inflection point. The sixth lens element with refractive power has an image-side surface being concave in a paraxial region thereof, wherein both of an object-side surface and the image-side surface of the sixth lens element are aspheric, and the image-side surface of the sixth lens element has at least one inflection point. The optical imaging lens assembly has a total of six lens elements with refractive power. When a focal length of the first lens element is  $f_1$ , a focal length of the second lens element, is  $f_2$ , a focal length of the optical imaging lens assembly is  $f$ , and a focal length of the fifth lens element is  $f_5$ , the following conditions are satisfied:

$$0 < (f1 + f2) / (f1 - f2) < 1.0; \text{ and}$$

$$f/f5 < 0.55.$$

According to yet another aspect of the present disclosure, an image capturing device includes the optical imaging lens assembly according to the aforementioned aspect and an image sensor, wherein the image sensor is located on the image side of the optical imaging lens assembly.

According to still yet another aspect of the present disclosure, a mobile terminal includes the image capturing device according to the foregoing aspect.

### BRIEF DESCRIPTION OF THE DRAWINGS

The disclosure can be more fully understood by reading the following detailed description of the embodiments, with reference made to the accompanying drawings as follows:

FIG. 1 is a schematic view of an image capturing device according to the 1st embodiment of the present disclosure;

FIG. 2 shows spherical aberration curves, astigmatic field curves and a distortion curve of the image capturing device according to the 1st embodiment;

FIG. 3 is a schematic view of an image capturing device according to the 2nd embodiment of the present disclosure;

FIG. 4 shows spherical aberration curves, astigmatic field curves and a distortion curve of the image capturing device according to the 2nd embodiment;

FIG. 5 is a schematic view of an image capturing device according to the 3rd embodiment of the present disclosure;

FIG. 6 shows spherical aberration curves, astigmatic field curves and a distortion curve of the image capturing device according to the 3rd embodiment;

FIG. 7 is a schematic view of an image capturing device according to the 4th embodiment of the present disclosure;

FIG. 8 shows spherical aberration curves, astigmatic field curves and a distortion curve of the image capturing device according to the 4th embodiment;

FIG. 9 is a schematic view of an image capturing device according to the 5th embodiment of the present disclosure;

FIG. 10 shows spherical aberration curves, astigmatic field curves and a distortion curve of the image capturing device according to the 5th embodiment;

FIG. 11 is a schematic view of an image capturing device according to the 6th embodiment of the present disclosure;

FIG. 12 shows spherical aberration curves, astigmatic field curves and a distortion curve of the image capturing device according to the 6th embodiment;

FIG. 13 shows Yc51 and Yc52 according to the fifth lens element of the FIG. 1;

FIG. 14 shows Yc62 according to the sixth lens element of the FIG. 1;

FIG. 15 shows a mobile terminal according to the 7th embodiment of the present disclosure;

FIG. 16 shows a mobile terminal according to the 8th embodiment of the present disclosure; and

FIG. 17 shows a mobile terminal according to the 9th embodiment of the present disclosure.

### DETAILED DESCRIPTION

An optical imaging lens assembly includes, in order from an object side to an image side, a first lens element, a second lens element, a third lens element, a fourth lens element, a fifth lens element, and a sixth lens element. The optical imaging lens assembly has a total of six lens elements with refractive power.

Each of the first through sixth lens elements a single and non-cemented lens element. That is, any two lens elements adjacent to each other are not cemented, and there is a space between the two lens elements. Moreover, the manufacturing process of the cemented lenses is more complex than the non-cemented lenses. In other words, of the first lens element, the second lens element, the third lens element, the fourth lens element, the fifth lens element and the sixth lens element of the optical imaging lens assembly, there is a space in a paraxial region between every pair of lens elements that are adjacent to each other. In particular, a second surface of one lens element and a first surface of the following lens element need to have accurate curvature to ensure these two lens elements will be highly cemented. However, during the cementing process, those two lens elements might not be highly cemented due to displacement and it is thereby not favorable for the image quality of the optical imaging lens assembly. Therefore, the optical imaging lens assembly of the present disclosure provides six non-cemented lens elements for improving the problem generated by the cemented lens elements.

The first lens element with negative refractive power can have an object-side surface being convex in a paraxial region thereof and an image-side surface being concave in a paraxial region thereof. Therefore, it is favorable for obtaining wider image scene and effectively reducing astigmatism so as to improve image quality.

The second lens element with positive refractive power can have an object-side surface being convex in a paraxial region thereof. Therefore, it is favorable for reducing the total track length of the optical imaging lens assembly. Furthermore, a curvature of the object-side surface of the second lens element is greater than a curvature of the image-side surface of the second lens element. Therefore the surface shapes are favorable for correcting aberration so as to improve image quality.

The third lens element can have positive refractive power and an image-side surface being convex in a paraxial region thereof. Therefore, it is favorable for effectively reducing the photosensitivity of the optical imaging lens assembly so as to increase manufacturing yield rate. Furthermore, the refractive power of the second lens element is weaker than the refractive power of the third lens element. Therefore, it is favorable for balancing the arrangement of the positive refractive powers so as to avoid excessive spherical aberrations.

The fourth lens element can have negative refractive power, an object-side surface being concave in a paraxial region thereof and an image-side surface being convex in a paraxial region thereof. Therefore, it is favorable for effectively correcting the astigmatism of the optical imaging lens assembly so as to maintain superior image quality.

The fifth lens element has an object-side surface being convex in a paraxial region thereof and an image-side surface being concave in a paraxial region thereof. Therefore, it is favorable for correcting the aberration of the off-axis and improving the illumination in a peripheral region of an image so as to avoid vignetting. Moreover, at least one of the object-side surface and the image-side surface of the fifth lens element can have at least one inflection point, so that it is favorable for reducing the incident angle of the off-axis on an image plane so as to improve the photosensitivity of the optical imaging lens assembly.

The sixth lens element can have an object-side surface being convex in a paraxial region thereof and an image-side surface being concave in a paraxial region thereof, wherein the image-side surface of the sixth lens element has at least one inflection point. Therefore, it is favorable for reducing the

back focal length of the optical imaging lens assembly so as to keep the optical imaging lens assembly compact. It is also favorable for correcting the aberration of the off-axis so as to achieve superior image quality.

When a focal length of the first lens element is  $f_1$ , and a focal length of the second lens element is  $f_2$ , the following condition is satisfied:  $0 < (f_1 + f_2) / (f_1 - f_2) < 1.0$ . Therefore, it is favorable for capturing wider image scene and controlling the total track length of the optical imaging lens assembly so as to avoid the optical imaging lens assembly from being oversized.

When a focal length of the optical imaging lens assembly is  $f$ , and a focal length of the fifth lens element is  $f_5$ , the following condition is satisfied:  $f / f_5 < 0.55$ . Therefore, it is favorable for reducing the photosensitivity of the optical imaging lens assembly so as to increase the manufacturing yield rate. Preferably, the following condition is satisfied:  $-1.5 < f / f_5 < 0.30$ .

When an axial distance between the object-side surface of the first lens element and an image plane is  $TL$ , and a focal length of the sixth lens element is  $f_6$ , the following condition is satisfied:  $-0.9 < TL / f_6 < 0.9$ . Therefore, it is favorable for reducing the total track length of the optical imaging lens assembly so as to maintain a compact size thereof.

When an Abbe number of the third lens element is  $V_3$ , and an Abbe number of the fourth lens element is  $V_4$ , the following condition is satisfied:  $0.20 < V_4 / V_3 < 0.60$ . Therefore, it is favorable for correcting the chromatic aberration of the optical imaging lens assembly so as to improve the image quality.

In the present disclosure, the aforementioned optical imaging lens assembly can further include a stop, such as an aperture stop, wherein an axial distance between the stop and the object-side surface of the first lens element is  $TS$ , and an axial distance between the stop and the image-side surface of the sixth lens element is  $SD$ , the following condition is satisfied:  $0 < |TS / SD| < 0.25$ . Therefore, it is favorable for making a balance between telecentricity and the functionality of wide viewing angle.

When a focal length of the third lens element is  $f_3$ , and a focal length of the fourth lens element is  $f_4$ , the following condition is satisfied:  $|f_3 / f_4| < 1.8$ . Therefore, it is favorable for balancing the refractive powers of the lens elements of the optical imaging lens assembly so as to correct the aberration of the optical imaging lens assembly.

When the focal length of the optical imaging lens assembly is  $f$ , and a curvature radius of the object-side surface of the fifth lens element is  $R_9$ , the following condition is satisfied:  $-1 < \text{Log}(R_9 / f) < 10$ . Therefore, it is favorable for correcting the astigmatism of the optical imaging lens assembly so as to maintain superior image quality.

When a vertical distance between a non-axial critical point on the object-side surface of the fifth lens element and an optical axis is  $Yc51$ , and a vertical distance between a non-axial critical point on the image-side surface of the fifth lens element and the optical axis is  $Yc52$ , the following condition is satisfied:  $0.1 < Yc51 / Yc52 < 1.2$ . Therefore, it is favorable for effectively reducing the incident angle of the off-axis on the image plane so as to improve the photosensitivity of the optical imaging lens assembly.

When the axial distance between the object-side surface of the first lens element and the image plane is  $TL$ , and a maximum image height of the optical imaging lens assembly (half of a diagonal length of an effective photosensitive area of an image sensor) the following condition is satisfied:  $TL / \text{ImgH} < 2.0$ . Therefore, it is favorable for controlling the total track length of the optical imaging lens assembly so as to keep the size compact thereof.

When a vertical distance between a non-axial critical point on the image-side surface of the sixth lens element and an optical axis is  $Yc62$ , and the focal length of the optical imaging lens assembly is  $f$ , the following condition is satisfied:  $0.2 < Yc62 / f < 0.8$ . Therefore, it is favorable for effectively correcting the aberration of the off-axis so as to improve the image quality of the image in the peripheral region.

According to the optical imaging lens assembly of the present disclosure, each of the refractive power of the first lens element, the fifth lens element and the sixth lens element is weaker than each of the refractive power of the second lens element, the third lens element and the fourth lens element. Therefore, it is favorable for effectively arranging the refractive powers of the lens elements so as to capture more of the image scene and avoid the optical imaging lens assembly from being oversized.

According to the optical imaging lens assembly of the present disclosure, a refractive power of a lens element is equal to a reciprocal of a focal length of the lens element. In particular, a stronger refractive power is defined as a larger absolute value of the refractive power; on the other hand, a weaker refractive power is defined as a smaller absolute value of the refractive power. Moreover, a curvature of a lens element is equal to a reciprocal of a curvature radius of the lens element. In particular, a greater curvature is defined as a larger absolute value of the curvature; on the other hand, a smaller curvature is defined as a smaller absolute value of the curvature.

According to the optical imaging lens assembly of the present disclosure, the lens elements thereof can be made of glass or plastic material. When the lens elements are made of glass material, the distribution of the refractive power of the optical imaging lens assembly may be more flexible to design. When the lens elements are made of plastic material, the manufacturing cost can be effectively reduced. Furthermore, surfaces of each lens element can be arranged to be aspheric, since the aspheric surface of the lens element is easy to form a shape other than spherical surface so as to have more controllable variables for eliminating the aberration thereof, and to further decrease the required number of the lens elements. Therefore, the total track length of the optical imaging lens assembly can also be reduced.

According to the optical imaging lens assembly of the present disclosure, each of an object-side surface and an image-side surface has a paraxial region and an off-axis region. The paraxial region refers to the region of the surface where light rays travel close to the optical axis, and the off-axis region refers to the region of the surface where light rays travel away from the optical axis. Particularly, when the lens element has a convex surface, it indicates that the surface is convex in the paraxial region thereof; when the lens element has a concave surface, it indicates that the surface is concave in the paraxial region thereof.

According to the optical imaging lens assembly of the present disclosure, a critical point is a non-axial point of the lens surface where its tangent is perpendicular to an optical axis.

According to the optical imaging lens assembly of the present disclosure, the optical imaging lens assembly can include at least one stop, such as an aperture stop, a glare stop or a field stop. The glare stop or the field stop is for eliminating the stray light and thereby improving the image resolution thereof.

According to the optical imaging lens assembly of the present disclosure, an aperture stop can be configured as a front stop or a middle stop. A front stop disposed between an imaged object and the first lens element can provide a longer

distance between an exit pupil of the optical imaging lens assembly and the image plane and thereby improves the image-sensing efficiency of an image sensor. A middle stop disposed between the first lens element and the image plane is favorable for enlarging the field of view of the optical imaging lens assembly and thereby provides a wider field of view for the same.

According to the optical imaging lens assembly of the present disclosure, the optical imaging lens assembly can be optionally applied to moving focus optical systems. Furthermore, the optical imaging lens assembly is featured with good correction ability and high image quality, and can be applied to 3D (three-dimensional) image capturing applications, in products such as digital cameras, mobile devices, digital tablets, wearable devices and other mobile terminals.

According to the present disclosure, an image capturing device is provided. The image capturing device includes the aforementioned optical imaging lens assembly according to the present disclosure and an image sensor, wherein the image sensor is disposed on the image side of the aforementioned optical imaging lens assembly, that is, the image sensor can be disposed on or near an image plane of the aforementioned optical imaging lens assembly. In the optical imaging lens assembly of the image capturing device, the first lens element has negative refractive power, so that it is favorable for capturing more of the image scene and controlling the total track length thereof so as to keep it compact. Furthermore, the surface shape of the fifth lens element is favorable for correcting the aberration of the off-axis, improving the image illumination in the peripheral region so as to avoid vignetting. Preferably, the image capturing device can further include a barrel member, a holding member or a combination thereof.

According to the present disclosure, a mobile terminal is provided, wherein the mobile terminal includes the aforementioned image capturing device. Therefore, it is favorable for keeping a compact size thereof, capturing more of the image scene, correcting the aberration of the off-axis, improving the image illumination in the peripheral region so as to avoid vignetting. Preferably, the mobile terminal can further include but not limited to a display, a control unit, a random access memory unit (RAM), a read only memory unit (ROM) or a combination thereof.

According to the above description of the present disclosure, the following 1st-9th specific embodiments are provided for further explanation.

#### 1st Embodiment

FIG. 1 is a schematic view of an image capturing device according to the 1st embodiment of the present disclosure. FIG. 2 shows, in order from left to right, spherical aberration curves, astigmatic field curves and a distortion curve of the image capturing device according to the 1st embodiment.

In FIG. 1, the image capturing device includes the optical imaging lens assembly (not otherwise herein labeled) of the present disclosure and an image sensor 190. The optical imaging lens assembly includes, in order from an object side to an image side, a first lens element 110, an aperture stop 100, a second lens element 120, a third lens element 130, a fourth lens element 140, a fifth lens element 150, a sixth lens element 160, an IR-cut filter 170 and an image plane 180, wherein the optical imaging lens assembly has a total of six lens elements (110-160) with refractive power. Moreover, of the first lens element 110, the second lens element 120, the third lens element 130, the fourth lens element 140, the fifth lens element 150 and the sixth lens element 160 of the optical imag-

ing lens assembly, there is a space in a paraxial region between every pair of lens elements that are adjacent to each other.

The first lens element 110 with negative refractive power has an object-side surface 111 being convex in a paraxial region thereof and an image-side surface 112 being concave in a paraxial region thereof, which are both aspheric, and the first lens element 110 is made of plastic material.

The second lens element 120 with positive refractive power has an object-side surface 121 being convex in a paraxial region thereof and an image-side surface 122 being convex in a paraxial region thereof, which are both aspheric, and the second lens element 120 is made of plastic material.

The third lens element 130 with positive refractive power has an object-side surface 131 being concave in a paraxial region thereof and an image-side surface 132 being convex in a paraxial region thereof, which are both aspheric, and the third lens element 130 is made of plastic material.

The fourth lens element 140 with negative refractive power has an object-side surface 141 being concave in a paraxial region thereof and an image-side surface 142 being convex in a paraxial region thereof, which are both aspheric, and the fourth lens element 140 is made of plastic material.

The fifth lens element 150 with negative refractive power has an object-side surface 151 being convex in a paraxial region thereof and an image-side surface 152 being concave in a paraxial region thereof, which are both aspheric, and the fifth lens element 150 is made of plastic material. Furthermore, both of the object-side surface 151 and the image-side surface 152 of the fifth lens element 150 have at least one inflection point.

The sixth lens element 160 with positive refractive power has an object-side surface 161 being convex in a paraxial region thereof and an image-side surface 162 being concave in a paraxial region thereof which are both aspheric, and the sixth lens element 160 is made of plastic material. Furthermore, the image-side surface 162 of the sixth lens element 160 has at least one inflection point.

The IR-cut filter 170 is made of glass and located between the sixth lens element 160 and the image plane 180, and will not affect the focal length of the optical imaging lens assembly. The image sensor 190 is disposed on or near the image plane 180 of the optical imaging lens assembly.

In addition, each of the refractive power of the first lens element 110, the fifth lens element 150 and the sixth lens element 160 is weaker than each of the refractive power of the second lens element 120, the third lens element 130 and the fourth lens element 140. A curvature of the object-side surface 121 of the second lens element 120 is greater than a curvature of the image-side surface 122 of the second lens element 120.

The equation of the aspheric surface profiles of the aforementioned lens elements of the 1st embodiment is expressed as follow

$$X(Y) = (Y^2/R)/(1 + \sqrt{1 - (1+k) \times (Y/R)^2}) + \sum_i (A_i) \times (Y^i),$$

where,

X is the relative distance between a point on the aspheric surface spaced at a distance Y from the optical axis and the tangential plane at the aspheric surface vertex on the optical axis;

Y is the vertical distance from the point on the aspheric surface to the optical axis;

R is the curvature radius;

k is the conic coefficient; and

Ai is the i-th aspheric coefficient.

In the optical imaging lens assembly of the image capturing device according to the 1st embodiment, when a focal length of the optical imaging lens assembly is f, an f-number of the optical imaging lens assembly is Fno, and half of a maximal field of view of the optical imaging lens assembly is HFOV, these parameters have the following values: f=3.48 mm; Fno=2.25; and HFOV=38.3 degrees.

In the optical imaging lens assembly of the image capturing device according to the 1st embodiment, when an Abbe number of the third lens element **130** is V3, and an Abbe number of the fourth lens element **140** is V4, the following condition is satisfied:  $V4/V3=0.46$ .

In the optical imaging lens assembly of the image capturing device according to the 1st embodiment, when a focal length of the first lens element **110** is f1 and a focal length of the second lens element **120** is f2, the following condition is satisfied:  $(f1+f2)/(f1-f2)=0.77$ .

In the optical imaging lens assembly of the image capturing device according to the 1st embodiment, when a focal length of the third lens element **130** is f3, and a focal length of the fourth lens element **140** is f4, the following condition is satisfied:  $|f3/f4|=1.20$ .

In the optical imaging lens assembly of the image capturing device according to the 1st embodiment, when the focal length of the optical imaging lens assembly is f, and a focal length of the fifth lens element **150** is f5, the following condition is satisfied:  $f/f5=-0.06$ .

In the optical imaging lens assembly of the image capturing device according to the 1st embodiment, when an axial distance between the object-side surface **111** of the first lens element **110** and an image plane **180** is TL, and a focal length of the sixth lens element **160** is f6 the following condition is satisfied:  $TL/f6=0.15$ .

In the optical imaging lens assembly of the image capturing device according to the 1st embodiment, when an axial

distance between the aperture stop **100** and the object-side surface **111** of the first lens element **110** is TS, and an axial distance between the aperture stop **100** and the image-side surface **162** of the sixth lens element **160** is SD (when the aforementioned displacement towards the image side, SD is positive; when the aforementioned displacement towards the object side, SD is negative), the following condition is satisfied:  $|TS/SD|=0.09$ .

In the optical imaging lens assembly of the image capturing device according to the 1st embodiment, when the focal length of the optical imaging lens assembly is f, and a curvature radius of the object-side surface **151** of the fifth lens element **150** is R9, the following condition is satisfied:  $\text{Log}(R9/f)=0.12$ .

FIG. **13** shows the fifth lens element **150** of the optical imaging lens assembly according to the FIG. **1**. In FIG. **13**, when a vertical distance between a non-axial critical point on the object-side surface **151** of the fifth lens element **150** and an optical axis is Yc51, and a vertical distance between a non-axial critical point on the image-side surface **152** of the fifth lens element **150** and the optical axis is Yc52, the following condition is satisfied:  $Yc51/Yc52=0.77$ .

FIG. **14** shows the sixth lens element **160** of the optical imaging lens assembly according to the FIG. **1**. In FIG. **14**, when a vertical distance between a non-axial critical point on the image-side surface **162** of the sixth lens element **160** and an optical axis is Yc62, and the focal length of the optical imaging lens assembly is f, the following condition is satisfied:  $Yc62/f=0.45$ .

In the optical imaging lens assembly of the image capturing device according to the 1st embodiment, when the axial distance between the object-side surface **111** of the first lens element **110** and the image plane **180** is TL, and a maximum image height of the optical imaging lens assembly (half of a diagonal length of an effective photosensitive area of an image sensor **190** is ImgH, the following condition is satisfied:  $TL/ImgH=1.75$ .

The detailed optical data of the 1st embodiment are shown in Table 1 and the aspheric surface data are, shown in Table 2 below.

TABLE 1

1st Embodiment							
f = 3.48 mm, Fno = 2.25, HFOV = 38.3 deg.							
Surface #		Curvature Radius	Thickness	Material	Index	Abbe #	Focal Length
0	Object	Plano	Infinity				
1	Lens 1	4.615 ASP	0.265	Plastic	1.535	56.3	-23.28
2		3.299 ASP	0.059				
3	Ape. Stop	Plano	0.013				
4	Lens 2	1.690 ASP	0.604	Plastic	1.535	56.3	2.96
5		-22.222 ASP	0.304				
6	Lens 3	-7.893 ASP	0.450	Plastic	1.544	55.9	5.17
7		-2.116 ASP	0.111				
8	Lens 4	-1.143 ASP	0.600	Plastic	1.614	25.6	-4.32
9		-2.408 ASP	0.164				
10	Lens 5	4.577 ASP	0.393	Plastic	1.607	26.6	-55.68
11		3.901 ASP	0.050				
12	Lens 6	1.513 ASP	0.856	Plastic	1.535	55.7	34.18
13		1.324 ASP	0.500				
14	IR-cut filter	Plano	0.200	Glass	1.517	64.2	—
15		Plano	0.426				
16	Image	Plano	—				

Note:

Reference wavelength is 587.6 nm (d-line).

TABLE 2

Aspheric Coefficients						
Surface #	1	2	4	5	6	7
k =	-2.2944E+01	-5.8988E+00	3.7232E-01	-1.0000E+01	9.9575E-01	2.1115E-01
A4 =	-6.8954E-02	-4.9272E-01	-4.8782E-01	-1.4670E-01	-1.4230E-01	-1.9414E-01
A6 =	1.9297E-01	1.2409E+00	9.0134E-01	-1.8517E-01	-1.0721E-01	-3.7355E-02
A8 =	-3.3662E-01	-2.1483E+00	-1.6676E+00	3.5582E-01	2.9455E-02	2.0034E-01
A10 =	3.5256E-01	2.2590E+00	1.7666E+00	-6.4283E-01	9.3318E-02	-1.4831E-01
A12 =	-1.4099E-01	-1.0137E+00	-1.0489E+00	6.3077E-01	-8.5079E-02	-2.4720E-02
A14 =			1.3773E-01	-2.6431E-01	5.1979E-02	5.8899E-02
Surface #	8	9	10	11	12	13
k =	-9.8415E-01	-1.2953E+00	-6.4675E+00	-8.3801E+00	-4.5280E+00	-1.7474E+00
A4 =	-1.2741E-01	-1.9677E-01	-1.0299E-02	1.1333E-01	-1.6057E-01	-1.9699E-01
A6 =	7.1761E-02	3.0672E-01	-1.3503E-01	-3.1087E-01	1.8198E-02	1.0587E-01
A8 =	4.1541E-01	-2.3159E-01	1.0471E-01	2.9507E-01	2.0670E-02	-4.4086E-02
A10 =	-8.0823E-01	1.1391E-01	-4.7598E-02	-1.7352E-01	-9.7313E-03	1.2957E-02
A12 =	6.1834E-01	-3.2704E-02	-6.6142E-04	6.1105E-02	2.1497E-03	-2.4237E-03
A14 =	-1.6396E-01	6.4351E-03	4.2702E-03	-1.1337E-02	-2.6478E-04	2.5292E-04
A16 =				8.4312E-04	1.1074E-05	-1.1210E-05

In Table 1, the curvature radius, the thickness and the focal length are shown in millimeters (mm). Surface numbers 0-16 represent the surfaces sequentially arranged from the object-side to the image-side along the optical axis. In Table 2, k represents the conic coefficient of the equation of the aspheric surface profiles. A4-A16 represent the aspheric coefficients ranging from the 4th order to the 16th order. The tables presented below for each embodiment are the corresponding schematic parameter and aberration curves, and the definitions of the tables are the same as Table 1 and Table 2 of the 1st embodiment. Therefore, an explanation in this regard will not be provided again.

#### 2nd Embodiment

FIG. 3 is a schematic view of an image capturing device according to the 2nd embodiment of the present disclosure. FIG. 4 shows, in order from left to right, spherical aberration curves, astigmatic field curves and a distortion curve of the image capturing device according to the 2nd embodiment.

In FIG. 3, the image capturing device includes the optical imaging lens assembly (not otherwise herein labeled) of the present disclosure and an image sensor 290. The optical imaging lens assembly includes, in order from an object side to an image side, an aperture stop 200, a first lens element 210, a second lens element 220, a third lens element 230, a fourth lens element 240, a fifth lens element 250, a sixth lens element 260, an IR-cut filter 270 and an image plane 280, wherein the optical imaging lens assembly has a total of six lens elements (210-260) with refractive power. Moreover, of the first lens element 210, the second lens element 220, the third lens element 230, the fourth lens element 240, the fifth lens element 250 and the sixth lens element 260 of the optical imaging lens assembly, there is a space in a paraxial region between every pair of lens elements that are adjacent to each other.

The first lens element 210 with negative refractive power has an object-side surface 211 being convex in a paraxial region thereof and an image-side surface 212 being concave in a paraxial region thereof, which are both aspheric, and the first lens element 210 is made of plastic material.

The second lens element 220 with positive refractive power has an object-side surface 221 being convex in a paraxial region thereof and an image-side surface 222 being concave

in a paraxial region thereof which are both aspheric, and the second lens element 220 is made of plastic material.

The third lens element 230 with positive refractive power has an object-side surface 231 being convex in a paraxial region thereof and an image-side surface 232 being convex in a paraxial region thereof, which are both aspheric, and the third lens element 230 is made of plastic material.

The fourth lens element 240 with negative refractive power has an object-side surface 241 being concave in a paraxial region thereof and an image-side surface 242 being convex in a paraxial region thereof, which are both aspheric, and the fourth lens element 240 is made of plastic material.

The fifth lens element 250 with negative refractive power has an object-side surface 251 being convex in a paraxial region thereof and an image-side surface 252 being concave in a paraxial region thereof, which are both aspheric, and the fifth lens element 250 is made of plastic material. Furthermore, both of the object-side surface 251 and the image-side surface 252 of the fifth lens element 250 have at least one inflection point.

The sixth lens element 260 with positive refractive power has an object-side surface 261 being convex in a paraxial region thereof and an image-side surface 262 being concave in a paraxial region thereof, which are both aspheric, and the sixth lens element 260 is made of plastic material. Furthermore, the image-side surface 262 of the sixth lens element 260 has at least one inflection point.

The IR-cut filter 270 is made of glass and located between the sixth lens element 260 and the image plane 280, and will not affect the focal length of the optical imaging lens assembly. The image sensor 290 is disposed on or near the image plane 280 of the optical imaging lens assembly.

In addition, each of the refractive power of the first lens element 210, the fifth lens element 250 and the sixth lens element 260 is weaker than each of the refractive power of the second lens element 220, the third lens element 230 and the fourth lens element 240. The refractive power of the second lens element 220 is weaker than the refractive power of the third lens element 230. A curvature of the object-side surface 221 of the second lens element 220 is greater than a curvature of the image-side surface 222 of the second lens element 220.

The detailed optical data of the 2nd embodiment are shown in Table 3 and the aspheric surface data are shown in Table 4 below.

TABLE 3

2nd Embodiment								
f = 3.39 mm, Fno = 2.25, HFOV = 39.1 deg.								
Surface #		Curvature Radius	Thickness	Material	Index	Abbe #	Focal Length	
0	Object	Plano	Infinity					
1	Ape. Stop	Plano	-0.090					
2	Lens 1	2.201 ASP	0.240	Plastic	1.535	56.3	-169.18	
3		2.067 ASP	0.100					
4	Lens 2	1.363 ASP	0.377	Plastic	1.535	56.3	7.17	
5		1.958 ASP	0.170					
6	Lens 3	4.476 ASP	0.613	Plastic	1.544	55.9	2.85	
7		-2.256 ASP	0.279					
8	Lens 4	-0.971 ASP	0.491	Plastic	1.650	21.4	-3.57	
9		-2.000 ASP	0.129					
10	Lens 5	3.686 ASP	0.360	Plastic	1.544	55.9	-169.50	
11		3.422 ASP	0.050					
12	Lens 6	1.429 ASP	0.963	Plastic	1.535	56.3	10.52	
13		1.466 ASP	0.500					
14	IR-cut filter	Plano	0.200	Glass	1.517	64.2	—	
15		Plano	0.385					
16	Image	Plano	—					

Note:  
Reference wavelength is 587.6 nm (d-line).

TABLE 4

Aspheric Coefficients						
Surface #	2	3	4	5	6	7
k =	-1.7893E+01	-9.5251E+00	-5.3148E-01	5.7410E-01	2.8694E-01	-4.1777E-01
A4 =	7.7558E-02	-4.2407E-01	-5.5367E-01	-2.8082E-01	-1.7449E-01	-1.6629E-01
A6 =	8.1956E-02	1.1813E+00	1.0015E+00	2.1291E-02	-7.8428E-02	-8.2487E-02
A8 =	-4.8298E-01	-2.3998E+00	-1.9471E+00	2.0029E-01	5.2283E-02	1.3179E-01
A10 =	6.6002E-01	2.3710E+00	1.9451E+00	-7.7213E-01	-7.9693E-02	-1.0063E-01
A12 =	-4.7129E-01	-1.1339E+00	-1.0135E+00	6.4851E-01	-2.1537E-01	-1.5531E-04
A14 =			-1.0072E-01	-2.0978E-01	2.0005E-01	2.5579E-02
Surface #	8	9	10	11	12	13
k =	-1.4449E+00	-5.3891E+00	3.5910E-01	-1.0000E+01	-4.8669E+00	-1.1567E+00
A4 =	-1.2382E-01	-2.3340E-01	6.2781E-02	1.8735E-01	-1.3744E-01	-2.0781E-01
A6 =	4.4761E-02	3.2333E-01	-1.8290E-01	-3.4845E-01	1.9977E-02	1.0381E-01
A8 =	4.1726E-01	-2.2726E-01	1.0856E-01	3.0340E-01	1.7561E-02	-4.3115E-02
A10 =	-8.1249E-01	1.0375E-01	-3.6379E-02	-1.7274E-01	-9.5131E-03	1.2904E-02
A12 =	6.2277E-01	-3.8788E-02	-3.4655E-03	6.0660E-02	2.3308E-03	-2.4503E-03
A14 =	-1.6592E-01	1.0622E-02	3.6133E-03	-1.1457E-02	-2.3065E-04	2.5712E-04
A16 =				8.8092E-04	-9.5897E-07	-1.1326E-05

In the 2nd embodiment, the equation of the aspheric surface profiles of the aforementioned lens elements is the same as the equation of the 1st embodiment. Also, the definitions of these parameters shown in the following table are the same as those stated in the 1st embodiment with corresponding values for the 2nd embodiment, so an explanation in this regard will not be provided again.

Moreover, these parameters can be calculated from Table and Table 4 as the following values and satisfy the following conditions:

2nd Embodiment			
f [mm]	3.39	TL/f6	0.46
Fno	2.25	TS/SD	0.02
HFOV [deg.]	39.1	Log(R9/f)	0.04
V4/V3	0.38	Yc51/Yc52	0.78
(f1 + f2)/(f1 - f2)	0.92	Yc62/f	0.46
f3/f4	0.80	TL/ImgH	1.70
f/f5	-0.02		

3rd Embodiment

FIG. 5 is a schematic view of an image capturing device according to the 3rd embodiment of the present disclosure. FIG. 6 shows, in order from left to right, spherical aberration curves, astigmatic field curves and a distortion curve of the image capturing device according to the 3rd embodiment.

In FIG. 5, the image capturing device includes the optical imaging lens assembly (not otherwise herein labeled) of the present disclosure and an image sensor 390. The optical imaging lens assembly includes, in order from an object side to an image side, a first lens element 310, an aperture stop 300, a second lens element 320, a third lens element 330, a fourth lens element 340, a fifth lens element 350, a sixth lens element 360, an IR-cut filter 370 and an image plane 380, wherein the optical imaging lens assembly has a total of six lens elements (310-360) with refractive power. Moreover, of the first lens element 310, the second lens element 320, the third lens element 330 the fourth lens element 340, the fifth lens ele-

ment 350 and the sixth lens element 360 of the optical imaging lens assembly, there is a space in a paraxial region between every pair of lens elements that are adjacent to each other.

The first lens element 310 with negative refractive power has an object-side surface 311 being convex in a paraxial region thereof and an image-side surface 312 being concave in a paraxial region thereof, which are both aspheric, and the first lens element 310 is made of glass material.

The second lens element 320 with positive refractive power has an object-side surface 321 being convex in a paraxial region thereof and an image-side surface 322 being concave in a paraxial region thereof, which are both aspheric, and the second lens element 320 is made of plastic material.

The third lens element 330 with positive refractive power has an object-side surface 331 being convex in a paraxial region thereof and an image-side surface 332 being convex in a paraxial region thereof, which are both aspheric, and the third lens element 330 is made of plastic material.

The fourth lens element 340 with positive refractive power has an object-side surface 341 being concave in a paraxial region thereof and an image-side surface 342 being convex in a paraxial region thereof, which are both aspheric, and the fourth lens element 340 is made of plastic material.

The fifth lens element 350 with negative refractive power has an object-side surface 351 being convex in a paraxial region thereof and an image-side surface 352 being concave in a paraxial region thereof, which are both aspheric, and the fifth lens element 350 is made of plastic material. Furthermore, both of the object-side surface 351 and the image-side surface 352 of the fifth lens element 350 have at least one inflection point.

The sixth lens element 360 with positive refractive power has an object-side surface 361 being convex in a paraxial region thereof and an image-side surface 362 being concave in a paraxial region thereof, which are both aspheric, and the sixth lens element 360 is made of plastic material. Furthermore, the image-side surface 362 of the sixth lens element 360 has at least one inflection point.

The IR-cut filter 370 is made of glass and located between the sixth lens element 360 and the image plane 380, and will not affect the focal length of the optical imaging lens assembly. The image sensor 390 is disposed on or near the image plane 380 of the optical imaging lens assembly.

In addition, a curvature of the object-side surface 321 of the second lens element 320 is greater than a curvature of the image-side surface 322 of the second lens element 320.

The detailed optical data of the 3rd embodiment are shown in Table 5 and the aspheric surface data are shown in Table 6 below.

TABLE 5

3rd Embodiment								
f = 3.56 mm, Fno = 2.50, HFOV = 39.3 deg.								
Surface #		Curvature	Radius	Thickness	Material	Index	Abbe #	Focal Length
0	Object	Plano		Infinity				
1	Lens 1	3.868	ASP	0.330	Glass	1.500	66.0	-38.68
2		3.132	ASP	0.081				
3	Ape. Stop	Plano		0.014				
4	Lens 2	1.602	ASP	0.464	Plastic	1.535	56.3	4.86
5		3.740	ASP	0.280				
6	Lens 3	289.335	ASP	0.440	Plastic	1.544	55.9	5.87
7		-3.228	ASP	0.068				
8	Lens 4	-1.632	ASP	0.600	Plastic	1.535	55.7	145.15
9		-1.803	ASP	0.050				
10	Lens 5	387.530	ASP	0.509	Plastic	1.634	23.8	-9.84
11		6.135	ASP	0.061				
12	Lens 6	1.520	ASP	0.873	Plastic	1.535	55.7	29.02
13		1.348	ASP	0.500				
14	IR-cut filter	Plano		0.200	Glass	1.517	64.2	—
15		Plano		0.750				
16	Image	Plano		—				

Note:  
Reference wavelength is 587.6 nm (d-line).

TABLE 6

Aspheric Coefficients							
Surface #	1	2	4	5	6	7	
k =	-8.1881E+00	-9.6326E+00	-5.1691E-01	-9.1189E+00	3.0000E+00	-1.8642E+00	
A4 =	-5.4914E-02	-4.9752E-01	-5.3087E-01	-1.5561E-01	-1.3425E-01	-1.7795E-01	
A6 =	2.0352E-01	1.2283E+00	8.8526E-01	-1.5533E-01	-1.0507E-01	-3.7754E-02	
A8 =	-3.4708E-01	-2.1218E+00	-1.6405E+00	3.6493E-01	6.5483E-03	1.9918E-01	
A10 =	3.4051E-01	2.1480E+00	1.8411E+00	-6.4760E-01	7.5723E-02	-1.4579E-01	
A12 =	-1.5507E-01	-1.0017E+00	-1.0962E+00	6.3842E-01	-8.2042E-02	-2.4732E-02	
A14 =			1.9196E-02	-2.6925E-01	7.1683E-02	5.5197E-02	

TABLE 6-continued

Aspheric Coefficients						
Surface #	8	9	10	11	12	13
k =	-1.1498E+00	-5.8623E-01	-1.0000E+01	-1.0000E+01	-3.6876E+00	-1.5188E+00
A4 =	-1.2013E-01	-2.0658E-01	9.6735E-03	1.1619E-01	-1.5807E-01	-2.0193E-01
A6 =	7.3517E-02	2.8992E-01	-1.4732E-01	-3.0218E-01	1.8629E-02	1.0433E-01
A8 =	4.1595E-01	-2.4133E-01	9.7435E-02	2.9549E-01	2.0659E-02	-4.3773E-02
A10 =	-8.0463E-01	1.1140E-01	-4.6946E-02	-1.7356E-01	-9.7136E-03	1.2984E-02
A12 =	6.1833E-01	-3.2045E-02	-8.8781E-04	6.1076E-02	2.1777E-03	-2.4224E-03
A14 =	-1.6628E-01	1.0243E-02	5.9432E-03	-1.1356E-02	-2.6810E-04	2.5213E-04
A16 =				8.3927E-04	1.0394E-05	-1.1255E-05

In the 3rd embodiment, the equation of the aspheric surface profiles of the aforementioned lens elements is the same as the equation of the 1st embodiment. Also, the definitions of these parameters shown in the following table are the same as those stated in the 1st embodiment with corresponding values for the 3rd embodiment, so an explanation in this regard will not be provided again.

Moreover, these parameters can be calculated from Table 5 and Table 6 as the following values and satisfy the following conditions:

3rd Embodiment			
f [mm]	3.56	TL/f6	0.18
Fno	2.50	TS/SD	0.12
HFOV [deg.]	39.3	Log(R9/f)	2.04
V4/V3	1.00	Yc51/Yc52	0.199/0.290
(f1 + f2)/(f1 - f2)	0.78	Yc62/f	0.42
f3/f4	0.04	TL/lmgH	1.84
f/f5	-0.36		

4th Embodiment

FIG. 7 is a schematic view of an image capturing device according to the 4th embodiment of the present disclosure. FIG. 8 shows, in order from left to right, spherical aberration curves, astigmatic field curves and a distortion curve of the image capturing device according to the 4th embodiment.

In FIG. 7, the image capturing device includes the optical imaging lens assembly (not otherwise herein labeled) of the present disclosure and an image sensor 490. The optical imaging lens assembly includes, in order from an object side to an image side, an aperture stop 400, a first lens element 410, a second lens element 420, a third lens element 430, a fourth lens element 440, a fifth lens element 450, a sixth lens element 460, an IR-cut filter 470 and an image plane 480, wherein the optical imaging lens assembly has a total of six lens elements (410-460) with refractive power. Moreover, of the first lens element 410, the second lens element 420, the third lens element 430, the fourth lens element 440, the fifth lens element 450 and the sixth lens element 460 of the optical imaging lens assembly, there is a space in a paraxial region between every pair of lens elements that are adjacent to each other.

The first lens element 410 with negative refractive power has an object-side surface 411 being convex in a paraxial region thereof and an image-side surface 412 being concave in a paraxial region thereof, which are both aspheric, and the first lens element 410 is made of plastic material.

The second lens element 420 with positive refractive power has an object-side surface 421 being convex in a paraxial region thereof and an image-side surface 422 being concave in a paraxial region thereof, which are both aspheric, and the second lens element 420 is made of plastic material.

The third lens element 430 with positive refractive power has an object-side surface 431 being convex in a paraxial region thereof and an image-side surface 432 being convex in a paraxial region thereof, which are both aspheric, and the third lens element 430 is made of plastic material.

The fourth lens element 440 with negative refractive power has an object-side surface 441 being concave in a paraxial region thereof and an image-side surface 442 being convex in a paraxial region thereof, which are both aspheric, and the fourth lens element 440 is made of plastic material.

The fifth lens element 450 with positive refractive power has an object-side surface 451 being convex in a paraxial region thereof and an image-side surface 452 being concave in a paraxial region thereof, which are both aspheric, and the fifth lens element 450 is made of plastic material. Furthermore, both of the object-side surface 451 and the image-side surface 452 of the fifth lens element 450 have at least one inflection point.

The sixth lens element 460 with positive refractive power has an object-side surface 461 being convex in a paraxial region thereof and an image-side surface 462 being concave in a paraxial region thereof, which are both aspheric, and the sixth lens element 460 is made of plastic material. Furthermore, the image-side surface 462 of the sixth lens element 460 has at least one inflection point.

The IR-cut filter 470 is made of glass and located between the sixth lens element 460 and the image plane 480, and will not affect the focal length of the optical imaging lens assembly. The image sensor 490 is disposed on or near the image plane 480 of the optical imaging lens assembly.

In addition, each of the refractive power of the first lens element 410, the fifth lens element 450 and the sixth lens element 460 is weaker than each of the refractive power of the second lens element 420, the third lens element 430 and the fourth lens element 440. The refractive power of the second lens element 420 is weaker than the refractive power of the third lens element 430. A curvature of the object-side surface 421 of the second lens element 420 is greater than a curvature of the image-side surface 422 of the second lens element 420.

The detailed optical data of the 4th embodiment are shown in Table 7 and the aspheric surface data are shown in Table 8 below.

TABLE 7

4th Embodiment							
f = 5.44 mm, Fno = 2.05, HFOV = 40.8 deg.							
Surface #		Curvature Radius	Thickness	Material	Index	Abbe #	Focal Length
0	Object	Plano	Infinity				
1	Ape. Stop	Plano	-0.165				
2	Lens 1	3.596 ASP	0.390	Plastic	1.544	55.9	-41.97
3		2.988 ASP	0.165				
4	Lens 2	2.023 ASP	0.571	Plastic	1.544	55.9	9.94
5		2.910 ASP	0.275				
6	Lens 3	6.285 ASP	0.934	Plastic	1.544	55.9	4.73
7		-4.132 ASP	0.430				
8	Lens 4	-1.755 ASP	0.916	Plastic	1.650	21.4	-5.39
9		-4.240 ASP	0.192				
10	Lens 5	9.557 ASP	0.618	Plastic	1.544	55.9	24.35
11		33.522 ASP	0.071				
12	Lens 6	2.262 ASP	1.335	Plastic	1.535	56.3	21.91
13		2.226 ASP	0.850				
14	IR-cut filter	Plano	0.340	Glass	1.517	64.2	—
15		Plano	0.826				
16	Image	Plano	—				

Note:  
Reference wavelength is 587.6 nm (d-line).

TABLE 8

Aspheric Coefficients						
Surface #	2	3	4	5	6	7
k =	-1.8790E+01	-9.7492E+00	-4.7761E-01	1.3620E+00	2.9695E+00	-1.3516E+00
A4 =	1.8594E-02	-7.9460E-02	-1.1066E-01	-5.3175E-02	-3.3020E-02	-3.1695E-02
A6 =	2.4426E-03	7.8694E-02	6.5531E-02	-1.6776E-05	-6.1653E-03	-5.2363E-03
A8 =	-1.2596E-02	-6.0010E-02	-4.2564E-02	5.1202E-03	2.3989E-03	3.4703E-03
A10 =	6.3156E-03	2.0827E-02	1.4658E-02	-6.5293E-03	-3.0019E-04	-9.2183E-04
A12 =	-1.5021E-03	-3.1728E-03	-3.6120E-03	1.8418E-03	-5.7843E-04	-1.5279E-05
A14 =			4.1562E-04	-1.8454E-04	1.5919E-04	3.5184E-05
Surface #	8	9	10	11	12	13
k =	-1.6816E+00	-2.6172E+00	2.4449E+00	3.0000E+00	-3.9747E+00	-1.1249E+00
A4 =	-1.9163E-02	-3.8805E-02	1.9349E-02	4.5896E-02	-2.5493E-02	-4.3561E-02
A6 =	4.0925E-03	2.2880E-02	-1.2970E-02	-2.4466E-02	1.3794E-03	7.3996E-03
A8 =	1.0093E-02	-5.7183E-03	2.7589E-03	7.3173E-03	4.0378E-04	-1.0572E-03
A10 =	-6.9354E-03	8.8037E-04	-3.2392E-04	-1.4588E-03	-8.4672E-05	1.0855E-04
A12 =	1.7947E-03	-1.0653E-04	-1.1633E-05	1.7717E-04	6.8141E-06	-7.1199E-06
A14 =	-1.6142E-04	9.8605E-06	3.8872E-06	-1.1546E-05	-2.1535E-07	2.6111E-07
A16 =				3.0756E-07	4.8534E-10	-4.0631E-09

In the 4th embodiment, the equation of the aspheric surface profiles of the aforementioned lens elements is the same as the equation of the 1st embodiment. Also, the definitions of these parameters shown in the following table are the same as those stated in the 1st embodiment with corresponding values for the 4th embodiment, so an explanation in this regard will not be provided again.

Moreover, these parameters can be calculated from Table 7 and Table 8 as the following values and satisfy the following conditions:

4th Embodiment			
f [mm]	5.44	TL/f6	0.36
Fno	2.05	TS/SD	0.03
HFOV [deg.]	40.8	Log(R9/f)	0.25
V4/V3	0.38	Yc51/Yc52	0.79
(f1 + f2)/(f1 - f2)	0.62	Yc62/f	0.51
f3/f4	0.88	TL/ImgH	1.61
f/f5	0.22		

5th Embodiment

FIG. 9 is a schematic view of an image capturing device according to the 5th embodiment of the present disclosure. FIG. 10 shows, in order from left to right, spherical aberration curves, astigmatic field curves and a distortion curve of the image capturing device according to the 5th embodiment.

In FIG. 9, the image capturing device includes the optical imaging lens assembly (not otherwise herein labeled) of the present disclosure and an image sensor 590. The optical imaging lens assembly includes, in order from an object side to an image side, a first lens element 510, an aperture stop 500, a second lens element 520, a third lens element 530, a fourth lens element 540, a fifth lens element 550, a sixth lens element 560, an IR-cut filter 570 and an image plane 580, wherein the optical imaging lens assembly has a total of six lens elements (510-560) with refractive power. Moreover of the first lens element 510, the second lens element 520, the third lens element 530, the fourth lens element 540, the fifth lens element 550 and the sixth lens element 560 of the optical imag-

ing lens assembly, there is a space in a paraxial region between every pair of lens elements that are adjacent to each other.

The first lens element 510 with negative refractive power has an object-side surface 511 being convex in a paraxial region thereof and an image-side surface 512 being concave in a paraxial region thereof, which are both aspheric, and the first lens element 510 is made of plastic material.

The second lens element 520 with positive refractive power has an object-side surface 521 being convex in a paraxial region thereof and an image-side surface 522 being concave in a paraxial region thereof which are both aspheric, and the second lens element 520 is made of plastic material.

The third lens element 530 with positive refractive power has an object-side surface 531 being convex in a paraxial region thereof and an image-side surface 532 being convex in a paraxial region thereof, which are both aspheric, and the third lens element 530 is made of plastic material.

The fourth lens element 540 with negative refractive power has an object-side surface 541 being concave in a paraxial region thereof and an image-side surface 542 being convex in a paraxial region thereof, which are both aspheric, and the fourth lens element 540 is made of plastic material.

The fifth lens element 550 with positive refractive power has an object-side surface 551 being convex in a paraxial region thereof and an image-side surface 552 being concave in a paraxial region thereof, which are both aspheric, and the fifth lens element 550 is made of plastic material. Further-

more, both of the object-side surface 551 and the image-side surface 552 of the fifth lens element 550 have at least one inflection point.

The sixth lens element 560 with negative refractive power has an object-side surface 561 being convex in a paraxial region thereof and an image-side surface 562 being concave in a paraxial region thereof, which are both aspheric, and the sixth lens element 560 is made of plastic material. Furthermore, the image-side surface 562 of the sixth lens element 560 has at least one inflection point.

The IR-cut filter 570 is made of glass and located between the sixth lens element 560 and the image plane 580, and will not affect the focal length of the optical imaging lens assembly. The image sensor 590 is disposed on or near the image plane 580 of the optical imaging lens assembly.

In addition, each of the refractive power of the first lens element 510, the fifth lens element 550 and the sixth lens element 560 is weaker than each of the refractive power of the second lens element 520, the third lens element 530 and the fourth lens element 540. The refractive power of the second lens element 520 is weaker than the refractive power of the third lens element 530. A curvature of the object-side surface 521 of the second lens element 520 is greater than a curvature of the image-side surface 522 of the second lens element 520.

The detailed optical data of the 5th embodiment are shown in Table 9 and the aspheric surface data are shown in Table 10 below.

TABLE 9

5th Embodiment							
f = 6.19 mm, Fno = 2.40, HFOV = 38.3 deg.							
Surface #		Curvature Radius	Thickness	Material	Index	Abbe #	Focal Length
0	Object	Plano	Infinity				
1	Lens 1	5.368 ASP	0.328	Plastic	1.632	23.4	-19.36
2		3.643 ASP	0.127				
3	Ape. Stop	Plano	0.060				
4	Lens 2	2.334 ASP	0.719	Plastic	1.544	55.9	9.18
5		3.907 ASP	0.248				
6	Lens 3	4.225 ASP	0.617	Plastic	1.544	55.9	6.06
7		-14.286 ASP	0.376				
8	Lens 4	-3.204 ASP	0.800	Plastic	1.639	23.5	-9.91
9		-7.114 ASP	0.136				
10	Lens 5	2.329 ASP	0.309	Plastic	1.607	26.6	21.20
11		2.701 ASP	1.411				
12	Lens 6	3.399 ASP	1.182	Plastic	1.535	56.3	-25.13
13		2.384 ASP	0.850				
14	IR-cut filter	Plano	0.340	Glass	1.517	64.2	—
15		Plano	0.607				
16	Image	Plano	—				

Note:  
Reference wavelength is 587.6 nm (d-line).

TABLE 10

Aspheric Coefficients						
Surface #	1	2	4	5	6	7
k =	-4.0258E+01	-6.3075E+00	5.3181E-02	3.6606E+00	1.9576E+00	-1.0000E+01
A4 =	-9.4671E-03	-7.7149E-02	-7.5476E-02	-5.9034E-02	-3.7580E-02	-2.1748E-02
A6 =	8.6910E-03	7.7457E-02	6.2194E-02	4.8354E-03	-1.6329E-03	1.3639E-03
A8 =	-1.0987E-02	-5.6914E-02	-4.0655E-02	5.2589E-03	1.1483E-03	2.7872E-03
A10 =	4.0272E-03	2.0907E-02	1.5611E-02	-6.4035E-03	-3.1733E-04	-1.1049E-03
A12 =	-5.5758E-04	-3.1287E-03	-3.4306E-03	1.8702E-03	-5.7809E-04	-1.6904E-05
A14 =			2.8804E-04	-2.2329E-04	1.5718E-04	3.1518E-05

TABLE 10-continued

Aspheric Coefficients						
Surface #	8	9	10	11	12	13
k =	-5.3943E-01	-1.0000E+01	-7.0257E+00	-9.7311E+00	-9.9837E+00	-9.2381E-01
A4 =	-3.0002E-02	-4.5704E-02	2.7201E-02	4.9394E-02	-2.0858E-02	-4.3825E-02
A6 =	7.7291E-03	2.3201E-02	-1.2614E-02	-2.5767E-02	-7.9505E-05	7.1994E-03
A8 =	9.9562E-03	-5.4107E-03	2.3107E-03	7.3524E-03	2.9124E-04	-1.0560E-03
A10 =	-6.9880E-03	8.0519E-04	-2.4106E-04	-1.4549E-03	-7.4072E-05	1.0766E-04
A12 =	1.7653E-03	-1.0879E-04	-3.9954E-06	1.7676E-04	8.3864E-06	-7.0825E-06
A14 =	-1.5138E-04	1.6170E-05	1.8502E-06	-1.1600E-05	-1.9618E-07	2.6614E-07
A16 =				3.1352E-07	-1.4022E-08	-4.3157E-09

In the 5th embodiment, the equation of the aspheric surface profiles of the aforementioned lens elements is the same as the equation of the 1st embodiment. Also, the definitions of these parameters shown in the following table are the same as those stated in the 1st embodiment with corresponding values for the 5th embodiment, so an explanation in this regard will not be provided again.

Moreover, these parameters can be calculated from Table and Table 10 as the following values and satisfy the following conditions:

5th Embodiment			
f [mm]	6.19	TL/f6	-0.32
Fno	2.40	TS/SD	0.08
HFOV [deg.]	38.3	Log(R9/f)	-0.42
V4/V3	0.42	Yc51/Yc52	0.92
(f1 + f2)/(f1 - f2)	0.36	Yc62/f	0.40
f3/f4	0.61	TL/ImgH	1.66
f/f5	0.29		

6th Embodiment

FIG. 11 is a schematic view of an image capturing device according to the 6th embodiment of the present disclosure. FIG. 12 shows, in order from left to right, spherical aberration curves, astigmatic field curves and a distortion curve of the image capturing device according to the 6th embodiment.

In FIG. 11 the image capturing device includes the optical imaging lens assembly (not otherwise herein labeled) of the present disclosure and an image sensor 690. The optical imaging lens assembly includes, in order from an object side to an image side, a first lens element 610, an aperture stop 600, a second lens element 620, a third lens element 630, a fourth lens element 640, a fifth lens element 650, a sixth lens element 660, an IR-cut filter 670 and an image plane 680, wherein the optical imaging lens assembly has a total of six lens elements (610-660) with refractive power. Moreover, of the first lens element 610, the second lens element 620, the third lens element 630, the fourth lens element 640, the fifth lens element 650 and the sixth lens element 660 of the optical imaging lens assembly, there is a space in a paraxial region between every pair of lens elements that are adjacent to each other.

The first lens element 610 with negative refractive power has an object-side surface 611 being convex in a paraxial region thereof and an image-side surface 612 being concave

in a paraxial region thereof, which are both aspheric, and the first lens element 610 is made of plastic material.

The second lens element 620 with positive refractive power has an object-side surface 621 being convex in a paraxial region thereof and an image-side surface 622 being concave in a paraxial region thereof, which are both aspheric, and the second lens element 620 is made of plastic material.

The third lens element 630 with positive refractive power has an object-side surface 631 being convex in a paraxial region thereof and an image-side surface 632 being concave in a paraxial region thereof, which are both aspheric, and the third lens element 630 is made of plastic material.

The fourth lens element 640 with negative refractive power has an object-side surface 641 being concave in a paraxial region thereof and an image-side surface 642 being convex in a paraxial region thereof, which are both aspheric, and the fourth lens element 640 is made of plastic material.

The fifth lens element 650 with negative refractive power has an object-side surface 651 being convex in a paraxial region thereof and an image-side surface 652 being concave in a paraxial region thereof, which are both aspheric, and the fifth lens element 650 is made of plastic material. Furthermore, both of the object-side surface 651 and the image-side surface 652 of the fifth lens element 650 have at least one inflection point.

The sixth lens element 660 with negative refractive power has an object-side surface 661 being convex in a paraxial region thereof and an image-side surface 662 being concave in a paraxial region thereof, which are both aspheric, and the sixth lens element 660 is made of plastic material. Furthermore, the image-side surface 662 of the sixth lens element 660 has at least one inflection point.

The IR-cut filter 670 is made of glass and located between the sixth lens element 660 and the image plane 680, and will not affect the focal length of the optical imaging lens assembly. The image sensor 690 is disposed on or near the image plane 680 of the optical imaging lens assembly.

In addition, each of the refractive power of the first lens element 610, the fifth lens element 650 and the sixth lens element 660 is weaker than each of the refractive power of the second lens element 620, the third lens element 630 and the fourth lens element 640. The refractive power of the second lens element 620 is weaker than the refractive power of the third lens element 630. A curvature of the object-side surface 621 of the second lens element 620 is greater than a curvature of the image-side surface 622 of the second lens element 620.

The detailed optical data of the 6th embodiment are shown in Table 11 and the aspheric surface data are shown in Table 12 below.

TABLE 11

6th Embodiment								
f = 6.17 mm, Fno = 2.45, HFOV = 37.8 deg.								
Surface #		Curvature Radius	Thickness	Material	Index	Abbe #	Focal Length	
0	Object	Plano	Infinity					
1	Lens 1	5.739	ASP	0.286	Plastic	1.632	23.4	-18.17
2		3.752	ASP	0.125				
3	Ape. Stop	Plano	0.060					
4	Lens 2	2.771	ASP	0.796	Plastic	1.544	55.9	7.78
5		7.198	ASP	0.394				
6	Lens 3	2.825	ASP	0.587	Plastic	1.544	55.9	6.32
7		14.650	ASP	0.585				
8	Lens 4	-2.748	ASP	0.747	Plastic	1.639	23.5	-10.72
9		-5.077	ASP	0.060				
10	Lens 5	3.445	ASP	0.280	Plastic	1.640	23.3	-476.85
11		3.299	ASP	0.967				
12	Lens 6	3.179	ASP	1.372	Plastic	1.535	56.3	-111.03
13		2.564	ASP	0.850				
14	IR-cut filter	Plano	0.340	Glass	1.517	64.2		—
15		Plano	0.641					
16	Image	Plano	—					

Note:  
Reference wavelength is 587.6 nm (d-line).

TABLE 12

Aspheric Coefficients						
Surface #	1	2	4	5	6	7
k =	-4.8693E+01	-2.8332E+00	3.6161E-01	1.4291E+01	6.1229E-01	2.5985E+00
A4 =	-1.7748E-02	-7.7807E-02	-5.8234E-02	-6.5405E-02	-3.9127E-02	3.3156E-03
A6 =	7.5643E-03	7.3853E-02	5.9032E-02	1.2874E-02	1.3873E-03	-5.0504E-03
A8 =	-1.0975E-02	-5.6385E-02	-4.0725E-02	3.8179E-03	-1.0536E-03	2.4178E-03
A10 =	4.0326E-03	2.0937E-02	1.5638E-02	-5.8110E-03	6.1985E-05	-1.1870E-03
A12 =	-5.0452E-04	-3.0980E-03	-3.3088E-03	1.9526E-03	-4.9553E-04	-1.9033E-05
A14 =			2.6830E-04	-2.5728E-04	1.1935E-04	3.9995E-05
Surface #	8	9	10	11	12	13
k =	-2.3450E-01	1.2295E+00	-9.8846E+00	-9.9985E+00	-9.8432E+00	-9.1737E-01
A4 =	-3.1635E-02	-5.6067E-02	5.5145E-03	2.8886E-02	-2.8491E-02	-4.3430E-02
A6 =	9.8804E-03	2.6284E-02	-1.1263E-02	-2.3548E-02	1.6880E-03	7.1816E-03
A8 =	1.0079E-02	-5.3457E-03	2.3759E-03	7.2924E-03	1.6134E-04	-1.0398E-03
A10 =	-7.0563E-03	6.7156E-04	-2.8505E-04	-1.4590E-03	-8.4934E-05	1.0506E-04
A12 =	1.7474E-03	-1.2543E-04	-9.0074E-06	1.7611E-04	8.4413E-06	-6.9781E-06
A14 =	-1.4967E-04	2.2599E-05	1.6753E-06	-1.1655E-05	-1.0805E-07	2.6851E-07
A16 =				3.4304E-07	-7.8890E-09	-4.5114E-09

In the 6th embodiment, the equation of the aspheric surface profiles of the aforementioned lens elements is the same as the equation of the 1st embodiment. Also, the definitions of these parameters shown in the following table are the same as those stated in the 1st embodiment with corresponding values for the 6th embodiment, so an explanation in this regard will not be provided again.

Moreover, these parameters can be calculated from Table 11 and Table 12 as the following values and satisfy the following conditions:

6th Embodiment			
f [mm]	6.17	TL/f6	-0.07
Fno	2.45	TS/SD	0.07
HFOV [deg.]	37.8	Log(R9/f)	-0.25
V4/V3	0.42	Yc51/Yc52	0.85
(f1 + f2)/(f1 - f2)	0.40	Yc62/f	0.38
f3/f4	0.59	TL/ImgH	1.65
f/f5	-0.01		

7th Embodiment

FIG. 15 is a schematic view of a mobile terminal 10 according to the 7th embodiment of the present disclosure. The mobile terminal 10 of the 7th embodiment is a smart phone, wherein the mobile terminal 10 includes an image capturing device 11. The image capturing device 11 includes an optical imaging lens assembly (not otherwise herein labeled) according to the present disclosure and an image sensor (not otherwise herein labeled), wherein the image sensor is disposed on or near an image plane of the optical imaging lens assembly.

8th Embodiment

FIG. 16 is a schematic view of a mobile terminal 20 according to the 8th embodiment of the present disclosure. The mobile terminal 20 of the 8th embodiment is a tablet personal computer, wherein the mobile terminal 20 includes an image capturing device 21. The image capturing device 21 includes an optical imaging lens assembly (not otherwise herein labeled) according to the present disclosure and an image

sensor (not otherwise herein labeled), wherein the image sensor is disposed on or near an image plane of the optical imaging lens assembly.

## 9th Embodiment

FIG. 17 is a schematic view of a mobile terminal 30 according to the 9th embodiment of the present disclosure. The mobile terminal 30 of the 9th embodiment is a head-mounted display, wherein the mobile terminal 30 includes an image capturing device 31. The image capturing device 31 includes an optical imaging lens assembly (not otherwise herein labeled) according to the present disclosure and an image sensor (not otherwise herein labeled), wherein the image sensor is disposed on or near an image plane of the optical imaging lens assembly.

The foregoing description, for purpose of explanation, has been described with reference to specific embodiments. It is to be noted that TABLES 1-12 show different data of the different embodiments; however, the data of the different embodiments are obtained from experiments. The embodiments were chosen and described in order to best explain the principles of the disclosure and its practical applications, to thereby enable others skilled in the art to best utilize the disclosure and various embodiments with various modifications as are suited to the particular use contemplated. The embodiments depicted above and the appended drawings are exemplary and are not intended to be exhaustive or to limit the scope of the present disclosure to the precise forms disclosed. Many modifications and variations are possible in view of the above teachings.

What is claimed is:

1. An optical imaging lens assembly comprising, in order from an object side to an image side:

- a first lens element having negative refractive power;
- a second lens element having positive refractive power;
- a third lens element;
- a fourth lens element having an object-side surface being concave in a paraxial region thereof;
- a fifth lens element having an object-side surface being convex in a paraxial region thereof and an image-side surface being concave in a paraxial region thereof, wherein both of the object-side surface and the image-side surface of the fifth lens element are aspheric; and
- a sixth lens element having an image-side surface being concave in a paraxial region thereof, wherein both of an object-side surface and the image-side surface of the sixth lens element are aspheric, and the image-side surface of the sixth lens element has at least one inflection point;

wherein the optical imaging lens assembly has a total of six lens elements, a curvature of an object-side surface of the second lens element is greater than a curvature of an image-side surface of the second lens element, a focal length of the first lens element is  $f_1$ , a focal length of the second lens element is  $f_2$ , a focal length of the optical imaging lens assembly is  $f$ , a focal length of the fifth lens element is  $f_5$ , and the following conditions are satisfied:

$$0 < (f_1 + f_2) / (f_1 - f_2) < 1.0; \text{ and}$$

$$f / f_5 < 0.55.$$

2. The optical imaging lens assembly of claim 1, wherein the object-side surface of the sixth lens element is convex in a paraxial region thereof.

3. The optical imaging lens assembly of claim 2, wherein an axial distance between an object-side surface of the first

lens element and an image plane is  $TL$ , a focal length of the sixth lens element is  $f_6$ , and the following condition is satisfied:

$$-0.9 < TL / f_6 < 0.9.$$

4. The optical imaging lens assembly of claim 1, wherein the fourth lens element has negative refractive power.

5. The optical imaging lens assembly of claim 4, wherein an Abbe number of the third lens element is  $V_3$ , an Abbe number of the fourth lens element is  $V_4$ , and the following condition is satisfied:

$$0.20 < V_4 / V_3 < 0.60.$$

6. The optical imaging lens assembly of claim 1, wherein the third lens element has positive refractive power, and the first lens element has an object-side surface being convex in a paraxial region thereof and an image-side surface being concave in a paraxial region thereof.

7. The optical imaging lens assembly of claim 1, further comprising:

- a stop, wherein an axial distance between the stop and an object-side surface of the first lens element is  $TS$ , an axial distance between the stop and the image-side surface of the sixth lens element is  $SD$ , and the following condition is satisfied:

$$0 < |TS / SD| < 0.25.$$

8. The optical imaging lens assembly of claim 1, wherein a focal length of the third lens element is  $f_3$ , a focal length of the fourth lens element is  $f_4$ , and the following condition is satisfied:

$$|f_3 / f_4| < 1.8.$$

9. An optical imaging lens assembly comprising, in order from an object side to an image side:

- a first lens element with negative refractive power having an object-side surface being convex in a paraxial region thereof and an image-side surface being concave in a paraxial region thereof;
  - a second lens element having positive refractive power;
  - a third lens element;
  - a fourth lens element;
  - a fifth lens element having an object-side surface being convex in a paraxial region thereof and an image-side surface being concave in a paraxial region thereof, wherein both of the object-side surface and the image-side surface of the fifth lens element are aspheric; and
  - a sixth lens element having an image-side surface being concave in a paraxial region thereof, wherein both of an object-side surface and the image-side surface of the sixth lens element are aspheric, and the image-side surface of the sixth lens element has at least one inflection point;
- wherein the optical imaging lens assembly has a total of six lens elements, a focal length of the first lens element is  $f_1$ , a focal length of the second lens element is  $f_2$ , a focal length of the optical imaging lens assembly is  $f$ , a focal length of the fifth lens element is  $f_5$ , and the following conditions are satisfied:

$$0 < (f_1 + f_2) / (f_1 - f_2) < 1.0; \text{ and}$$

$$f / f_5 < 0.55.$$

10. The optical imaging lens assembly of claim 9, wherein the third lens element has positive refractive power and has an image-side surface being convex in a paraxial region thereof.

29

11. The optical imaging lens assembly of claim 9, wherein the second lens element has an object-side surface being convex in a paraxial region thereof.

12. The optical imaging lens assembly of claim 9, wherein the refractive power of the second lens element is weaker than the refractive power of the third lens element. 5

13. The optical imaging lens assembly of claim 9, wherein the focal length of the optical imaging lens assembly is  $f$ , a curvature radius of the object-side surface of the fifth lens element is  $R9$ , and the following condition is satisfied: 10

$$-1 < \text{Log}(R9/f) < 10.$$

14. The optical imaging lens assembly of claim 9, wherein the focal length of the optical imaging lens assembly is  $f$ , the focal length of the fifth lens element is  $f5$ , and the following condition is satisfied: 15

$$-1.5 < f/f5 < 0.30.$$

15. The optical imaging lens assembly of claim 9, wherein a vertical distance between a non-axial critical point on the object-side surface of the fifth lens element and an optical axis is  $Yc51$ , a vertical distance between a non-axial critical point on the image-side surface of the fifth lens element and the optical axis is  $Yc52$ , and the following condition is satisfied: 20

$$0.1 < Yc51/Yc52 < 1.2.$$

16. The optical imaging lens assembly of claim 9, wherein an axial distance between the object-side surface of the first lens element and an image plane is  $TL$ , a maximum image height of the optical imaging lens assembly is  $ImgH$ , and the following condition is satisfied: 30

$$TL/ImgH < 2.0.$$

17. An optical imaging lens assembly comprising, in order from an object side to an image side: 35

- a first lens element having negative refractive power;
- a second lens element having positive refractive power;
- a third lens element having positive refractive power; to a fourth lens element;
- a fifth lens element having an object-side surface being convex in a paraxial region thereof and an image-side surface being concave in a paraxial region thereof, wherein both of the object-side surface and the image-side surface of the fifth lens element are aspheric, and at least one of the object-side surface and the image-side surface of the fifth lens element has at least one inflection point; and 40
- a sixth lens element having an image-side surface being concave in a paraxial region thereof, wherein both of an object-side surface and the image-side surface of the 45

30

sixth lens element are aspheric, and the image-side surface of the sixth lens element has at least one inflection point;

wherein the optical imaging lens assembly has a total of six lens elements, a focal length of the first lens element is  $f1$ , a focal length of the second lens element is  $f2$ , a focal length of the optical imaging lens assembly is  $f$ , a focal length of the fifth lens element is  $f5$ , and the following conditions are satisfied:

$$0 < (f1+f2)/(f1-f2) < 1.0; \text{ and}$$

$$f/f5 < 0.55.$$

18. The optical imaging lens assembly of claim 17, wherein the object-side surface of the sixth lens element is convex in a paraxial region thereof.

19. The optical imaging lens assembly of claim 17, wherein the fourth lens element has an object-side surface being concave in a paraxial region thereof and an image-side surface being convex in a paraxial region thereof.

20. The optical imaging lens assembly of claim 17, wherein each of the refractive power of the first lens element, the fifth lens element and the sixth lens element is weaker than each of the refractive power of the second lens element, the third lens element and the fourth lens element.

21. The optical imaging lens assembly of claim 17, wherein an Abbe number of the third lens element is  $V3$ , an Abbe number of the fourth lens element is  $V4$ , and the following condition is satisfied: 25

$$0.20 < V4/V3 < 0.60.$$

22. The optical imaging lens assembly of claim 17, wherein a vertical distance between a non-axial critical point on the image-side surface of the sixth lens element and an optical axis is  $Yc62$ , the focal length of the optical imaging lens assembly is  $f$ , and the following condition is satisfied: 30

$$0.2 < Yc62/f < 0.8.$$

23. The optical imaging lens assembly of claim 17, wherein of the first lens element, the second lens element, the third lens element, the fourth lens element, the fifth lens element and the sixth lens element of the optical imaging lens assembly, there is a space in a paraxial region between every pair of lens elements that are adjacent to each other.

24. An image capturing device, comprising: the optical imaging lens assembly of claim 17; and an image sensor, wherein the image sensor is located on the image side of the optical imaging lens assembly.

25. A mobile terminal, comprising: the image capturing device of claim 24.

\* \* \* \* \*

UNITED STATES PATENT AND TRADEMARK OFFICE  
**CERTIFICATE OF CORRECTION**

PATENT NO. : 9,304,295 B2  
APPLICATION NO. : 14/228266  
DATED : April 5, 2016  
INVENTOR(S) : Huang

Page 1 of 1

It is certified that error appears in the above-identified patent and that said Letters Patent is hereby corrected as shown below:

In the claims

Column 27, line 55, Claim 1 “the first lens element is f1 a focal length”, should read as “the first lens element is f1, a focal length”.

Column 29, line 39, Claim 17 “to a fourth lens element”, should read as “a fourth lens element”.

Signed and Sealed this  
Twenty-eighth Day of June, 2016

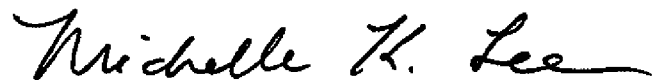

Michelle K. Lee  
*Director of the United States Patent and Trademark Office*