



US009170400B2

(12) **United States Patent**
Huang

(10) **Patent No.:** **US 9,170,400 B2**
(45) **Date of Patent:** **Oct. 27, 2015**

(54) **PHOTOGRAPHING OPTICAL LENS ASSEMBLY, IMAGE CAPTURING UNIT AND MOBILE DEVICE**

(58) **Field of Classification Search**
CPC G02B 9/62; G02B 13/0045
See application file for complete search history.

(71) Applicant: **LARGAN Precision Co., Ltd.**,
Taichung (TW)

(56) **References Cited**

(72) Inventor: **Hsin-Hsuan Huang**, Taichung (TW)

U.S. PATENT DOCUMENTS

(73) Assignee: **LARGAN PRECISION CO., LTD.**,
Taichung (TW)

8,390,940	B2 *	3/2013	Tsai et al.	359/713
8,830,594	B1	9/2014	Hsu et al.	
2012/0194726	A1	8/2012	Huang et al.	
2014/0111872	A1	4/2014	Tang et al.	
2014/0347745	A1	11/2014	Shinohara	
2014/0354872	A1	12/2014	Chen et al.	

(*) Notice: Subject to any disclaimer, the term of this patent is extended or adjusted under 35 U.S.C. 154(b) by 14 days.

* cited by examiner

Primary Examiner — Joseph P Martinez

(21) Appl. No.: **14/295,072**

(74) *Attorney, Agent, or Firm* — Locke Lord LLP; Tim Tingkang Xia, Esq.

(22) Filed: **Jun. 3, 2014**

(57) **ABSTRACT**

(65) **Prior Publication Data**

US 2015/0268447 A1 Sep. 24, 2015

A photographing optical lens assembly includes a first lens element, a second lens element, a third lens element, a fourth lens element, a fifth lens element and a sixth lens element. The first lens element has positive refractive power. The second lens element with negative refractive power has an object-side surface being convex in a paraxial region thereof and an image-side surface being concave in a paraxial region thereof. The third lens element, the fourth lens element, the fifth lens element and the sixth lens element have refractive power. The sixth lens element has an image-side surface being concave in a paraxial region thereof, wherein the image-side surface of the sixth lens element has at least one inflection point. The photographing optical lens assembly has a total of six lens elements with refractive power.

(30) **Foreign Application Priority Data**

Mar. 21, 2014 (TW) 103110739 A

(51) **Int. Cl.**

G02B 9/62	(2006.01)
G02B 13/00	(2006.01)
H04N 5/225	(2006.01)

(52) **U.S. Cl.**

CPC **G02B 9/62** (2013.01); **G02B 13/0045** (2013.01); **H04N 5/2254** (2013.01)

26 Claims, 16 Drawing Sheets

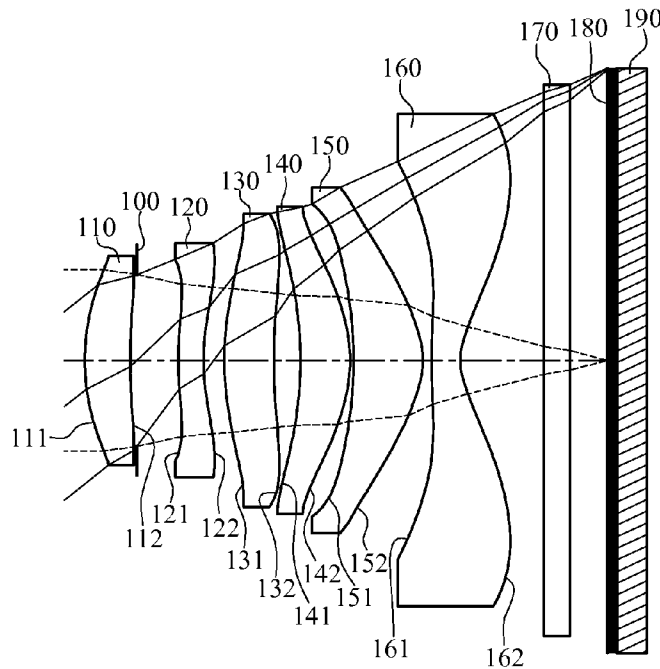

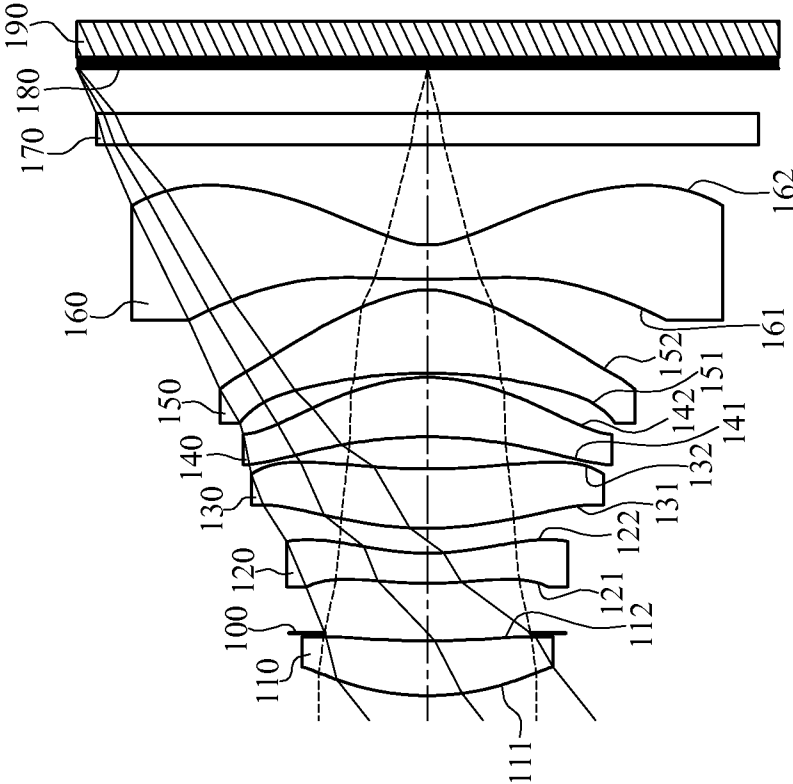

FIG.1

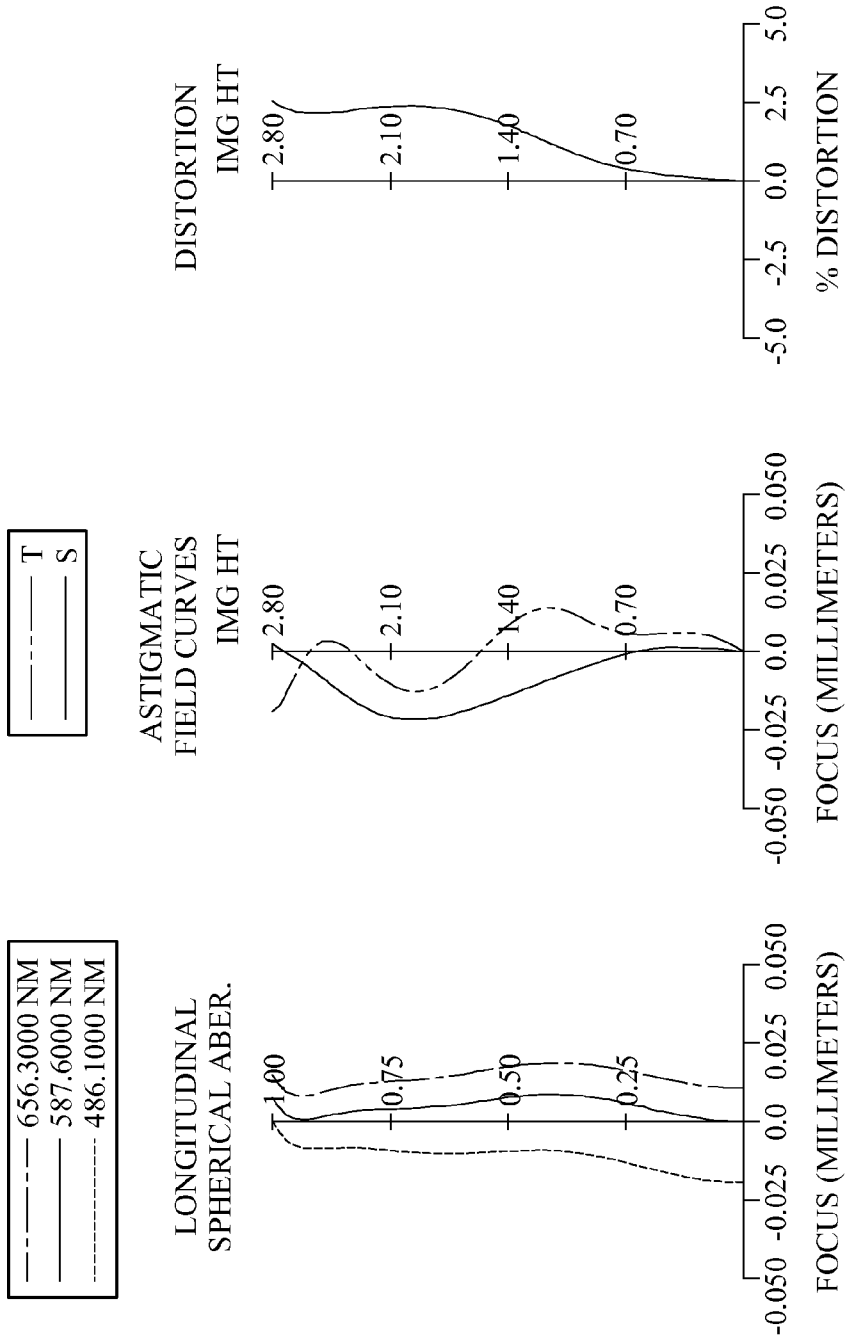

FIG.2

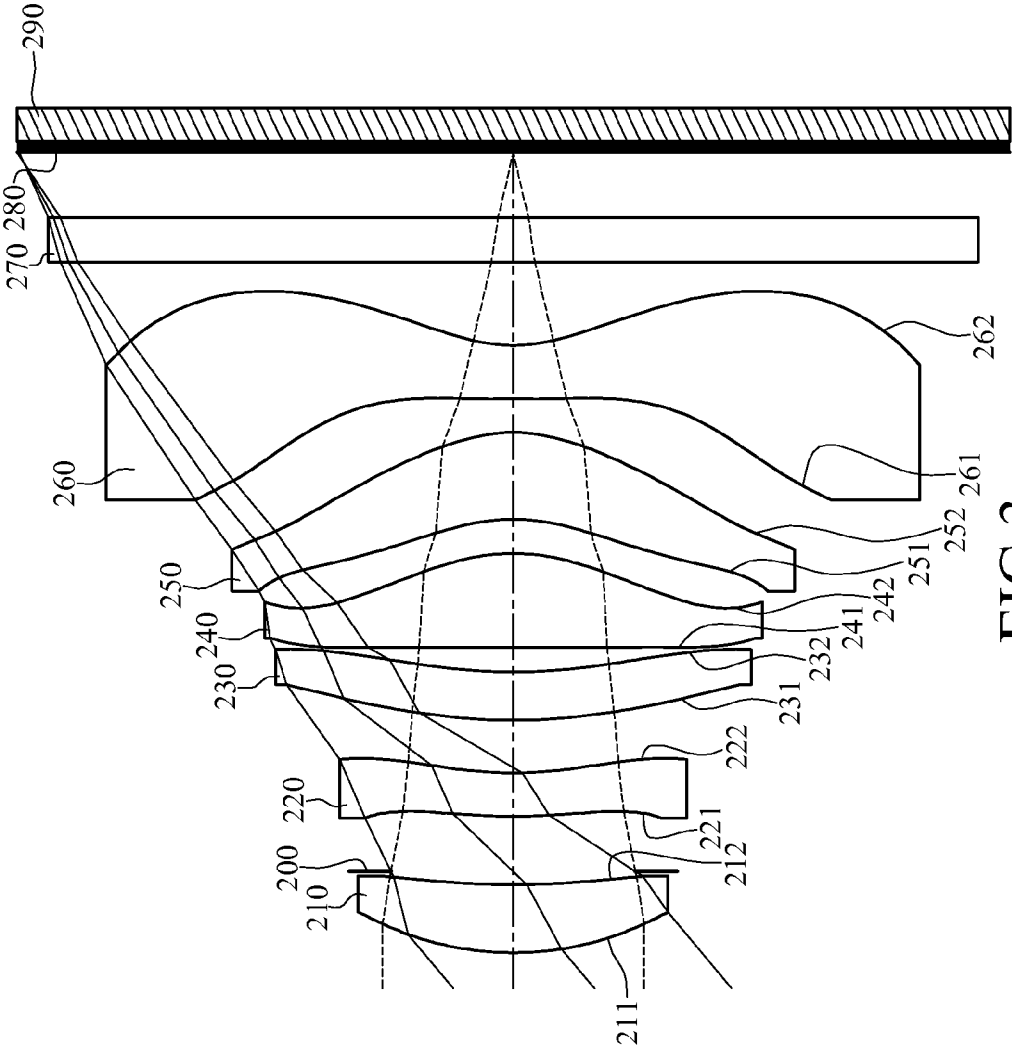

FIG.3

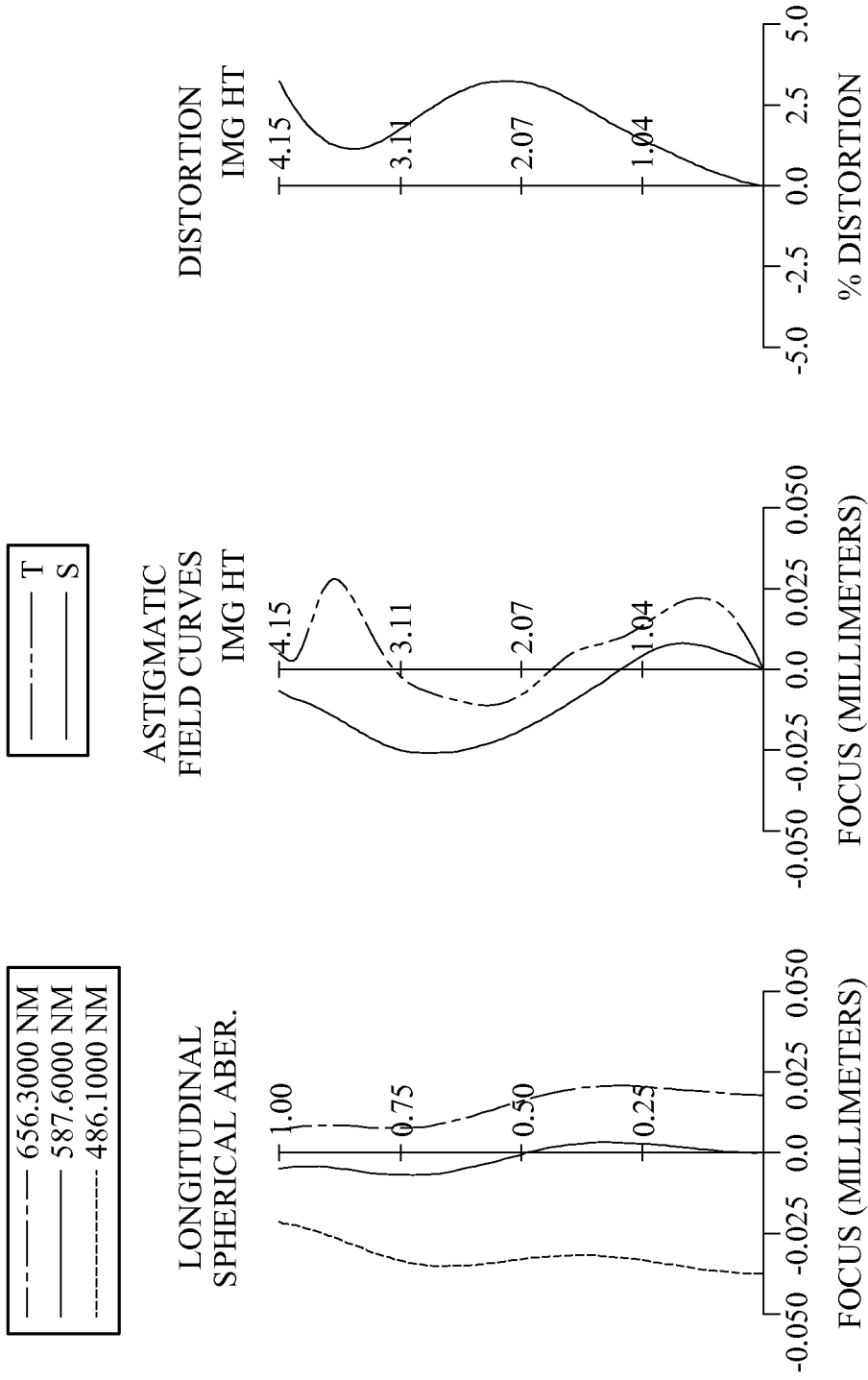

FIG.4

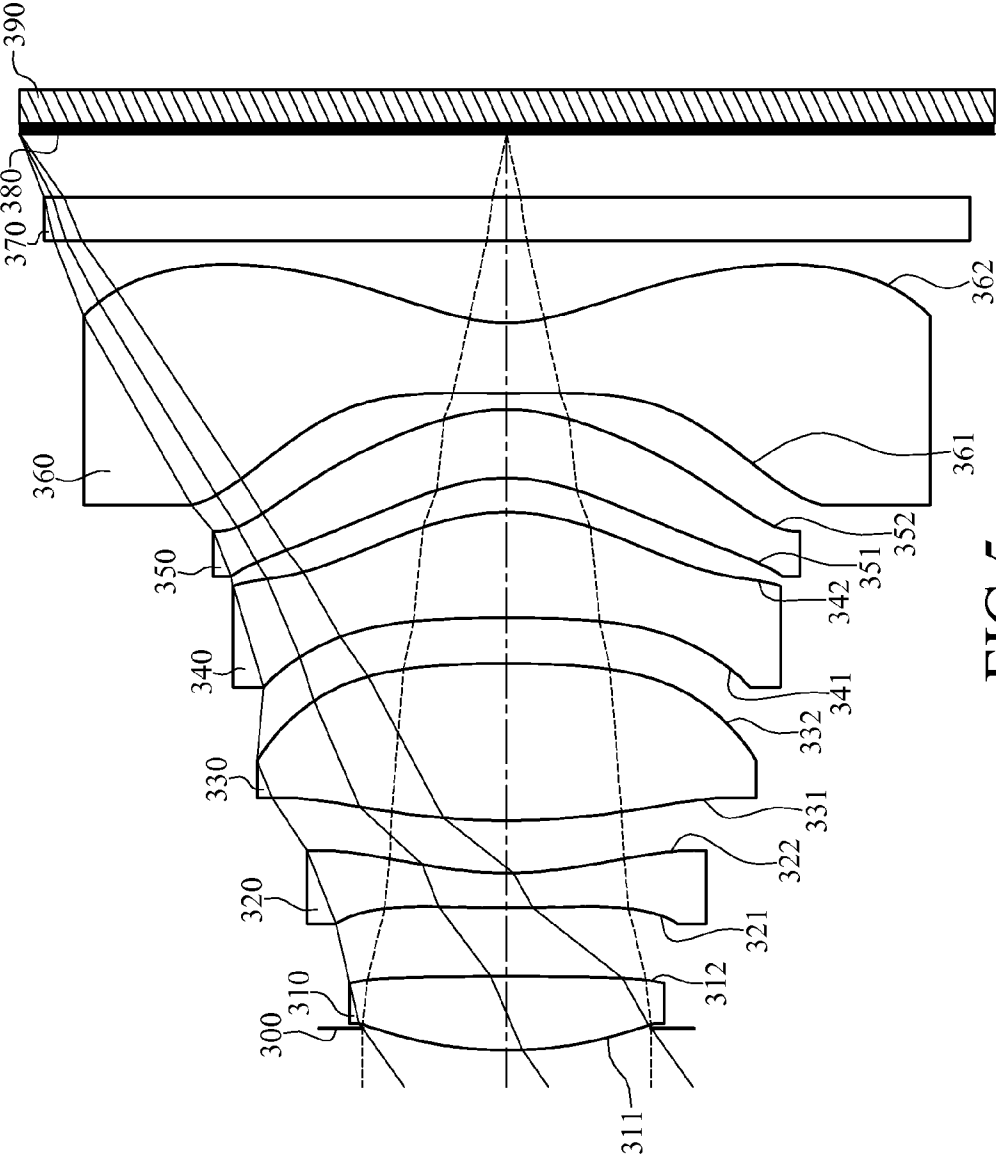

FIG.5

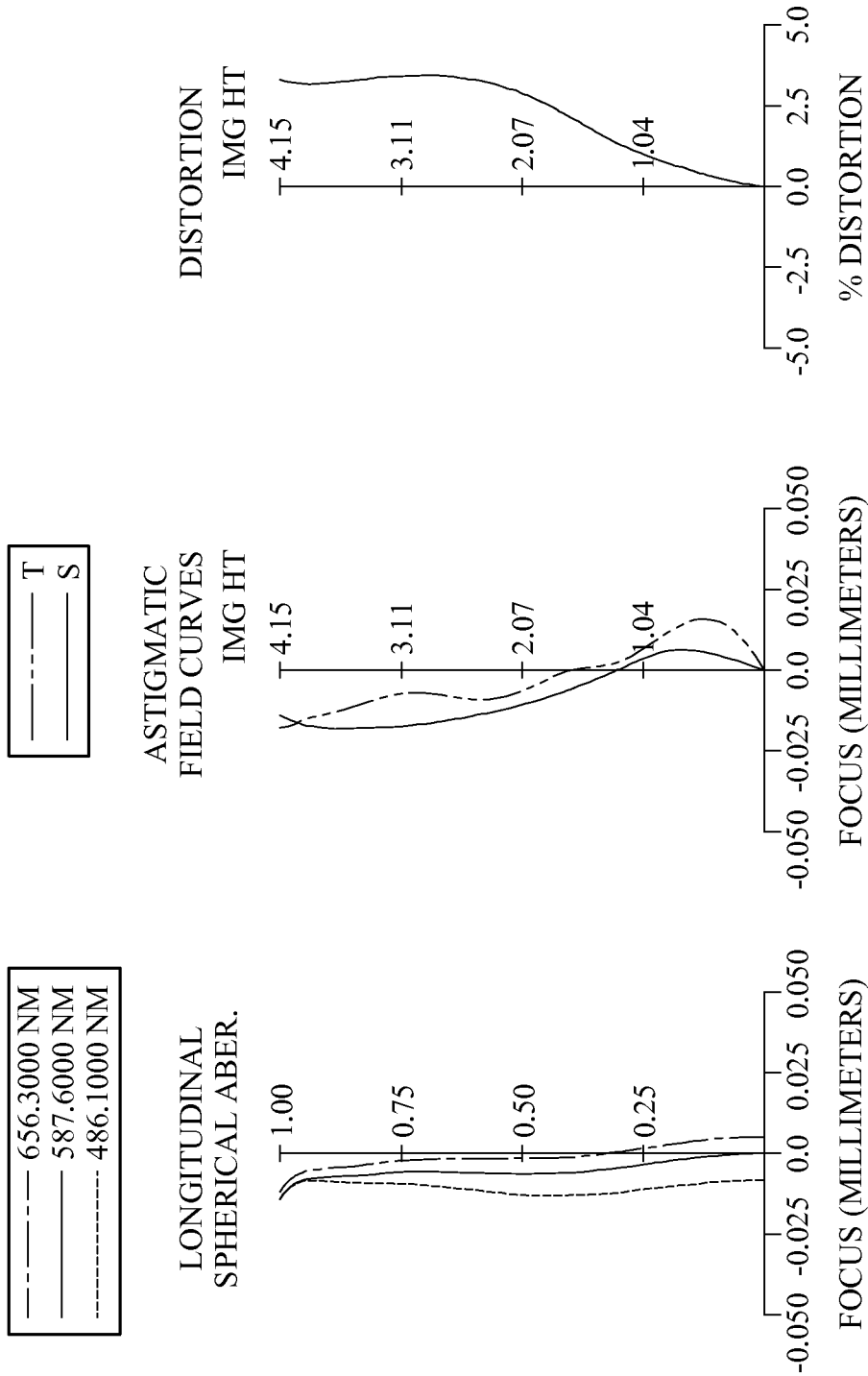

FIG.6

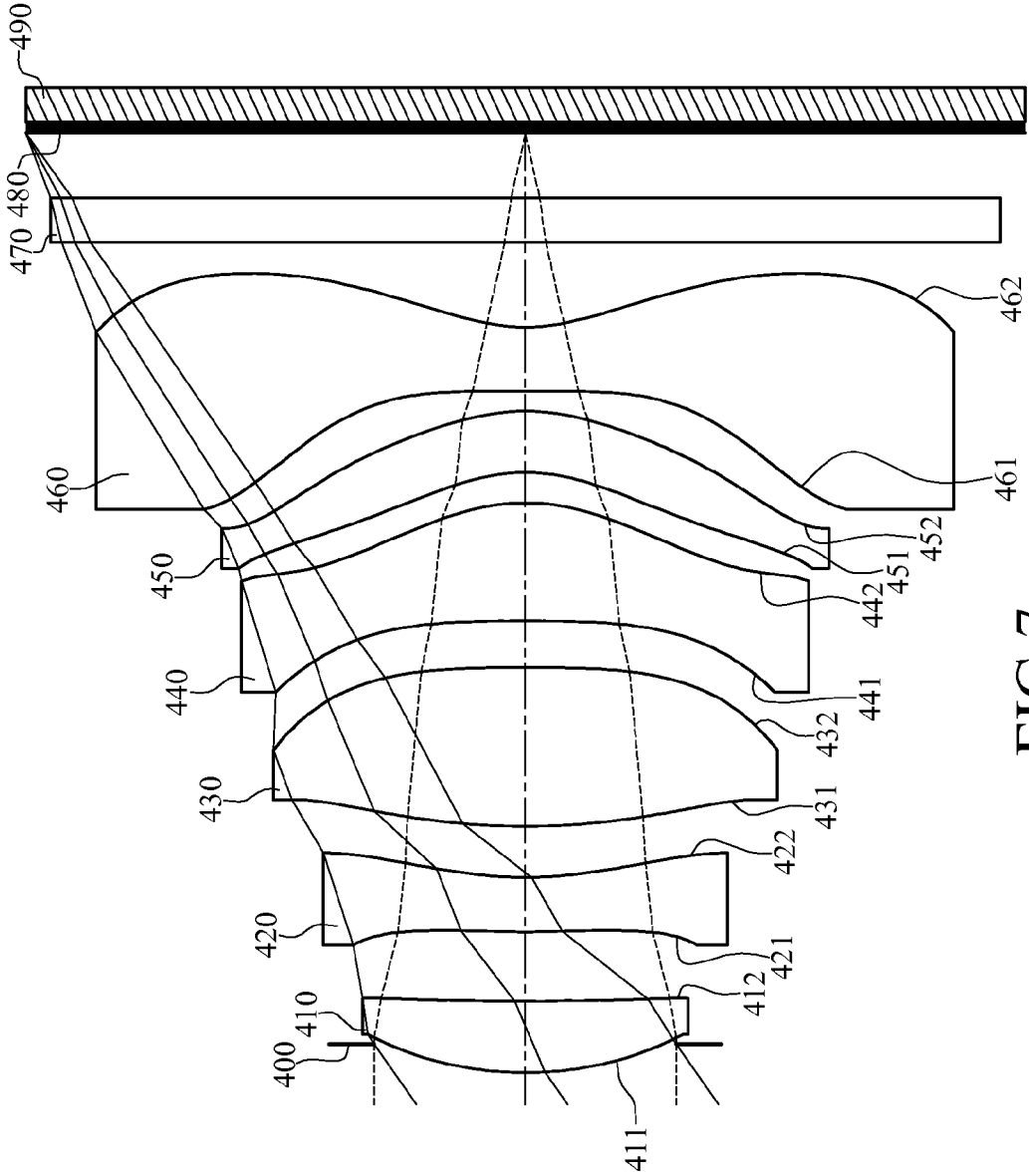

FIG.7

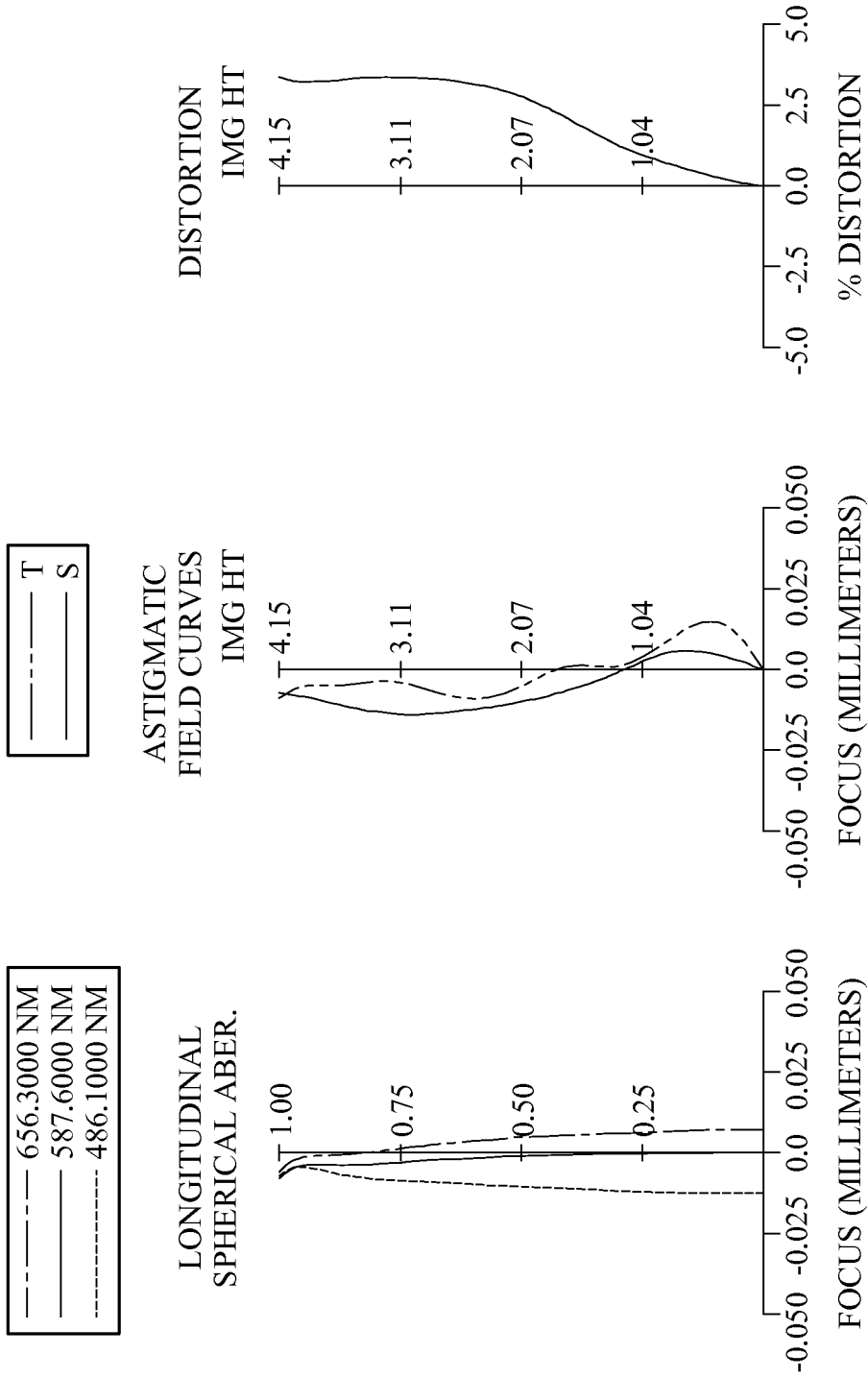

FIG. 8

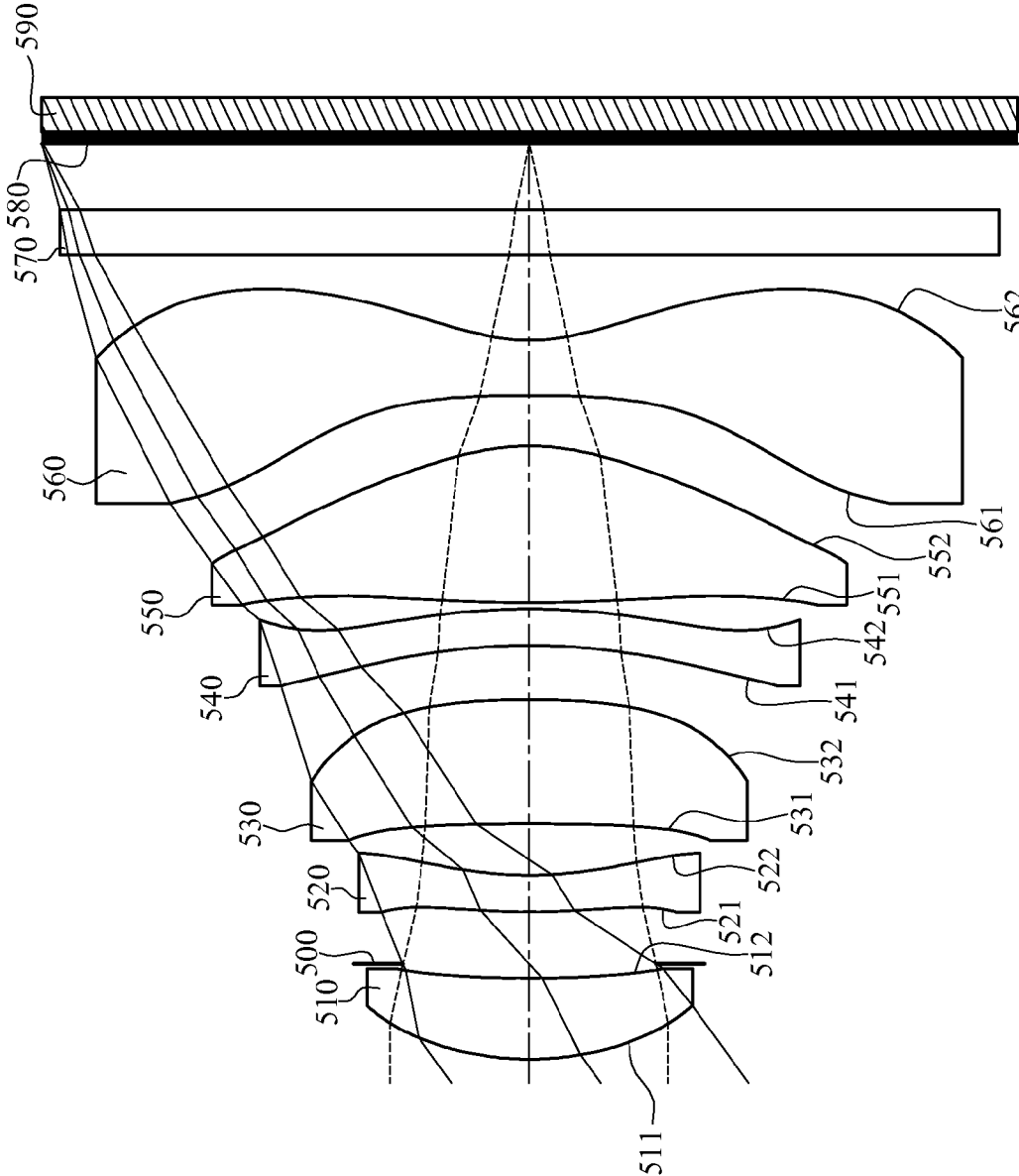

FIG.9

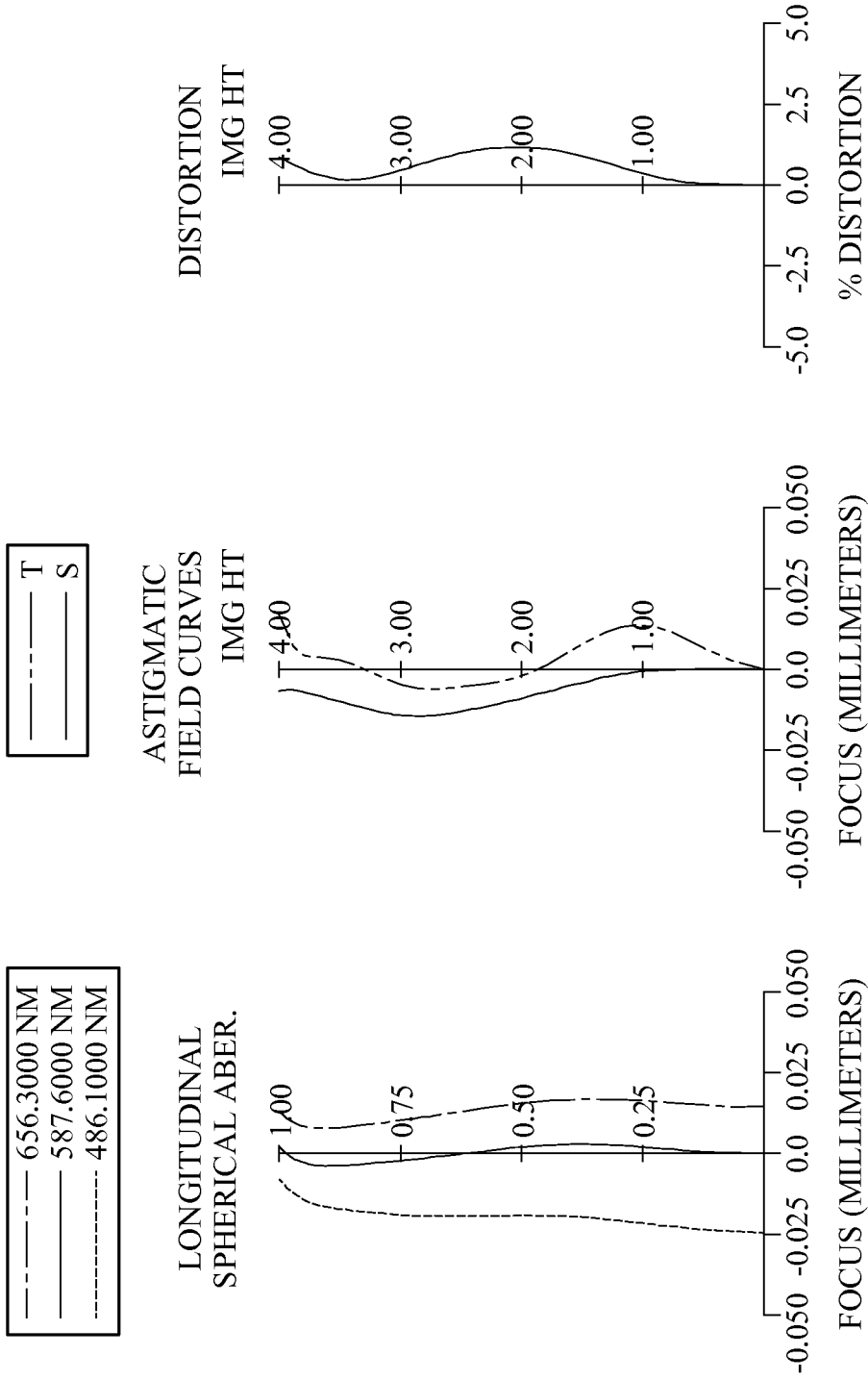

FIG.10

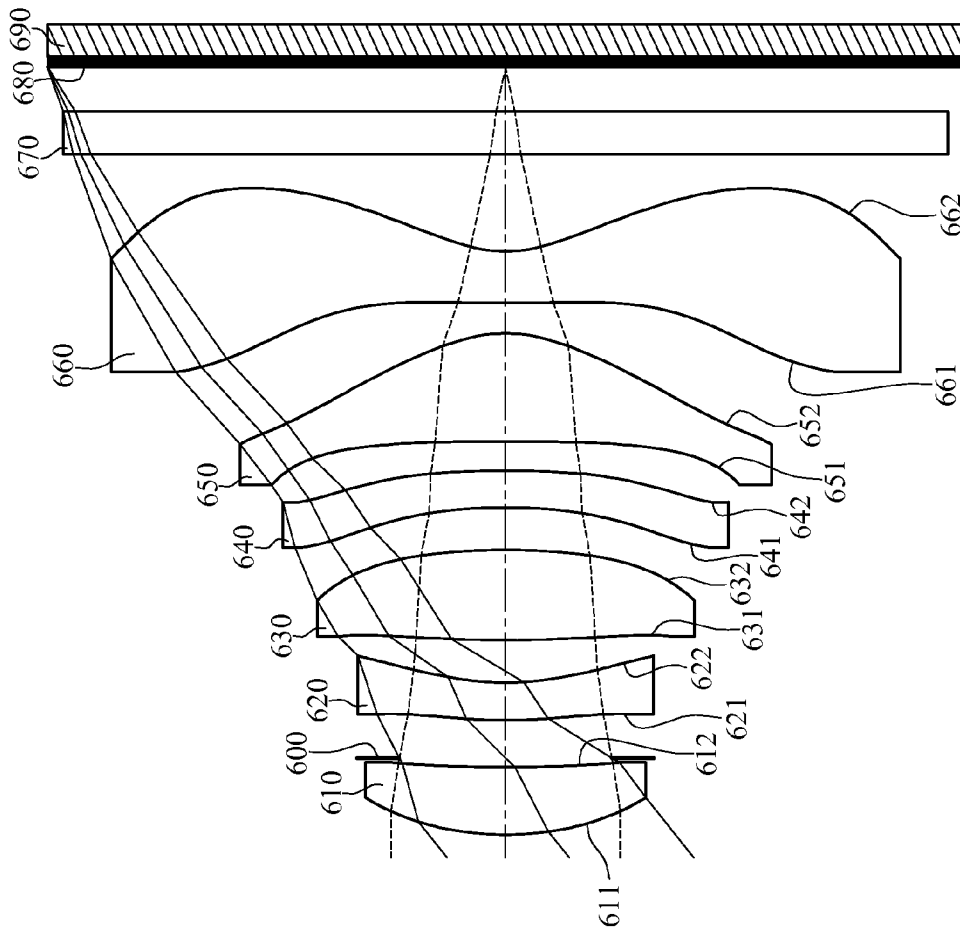

FIG. 11

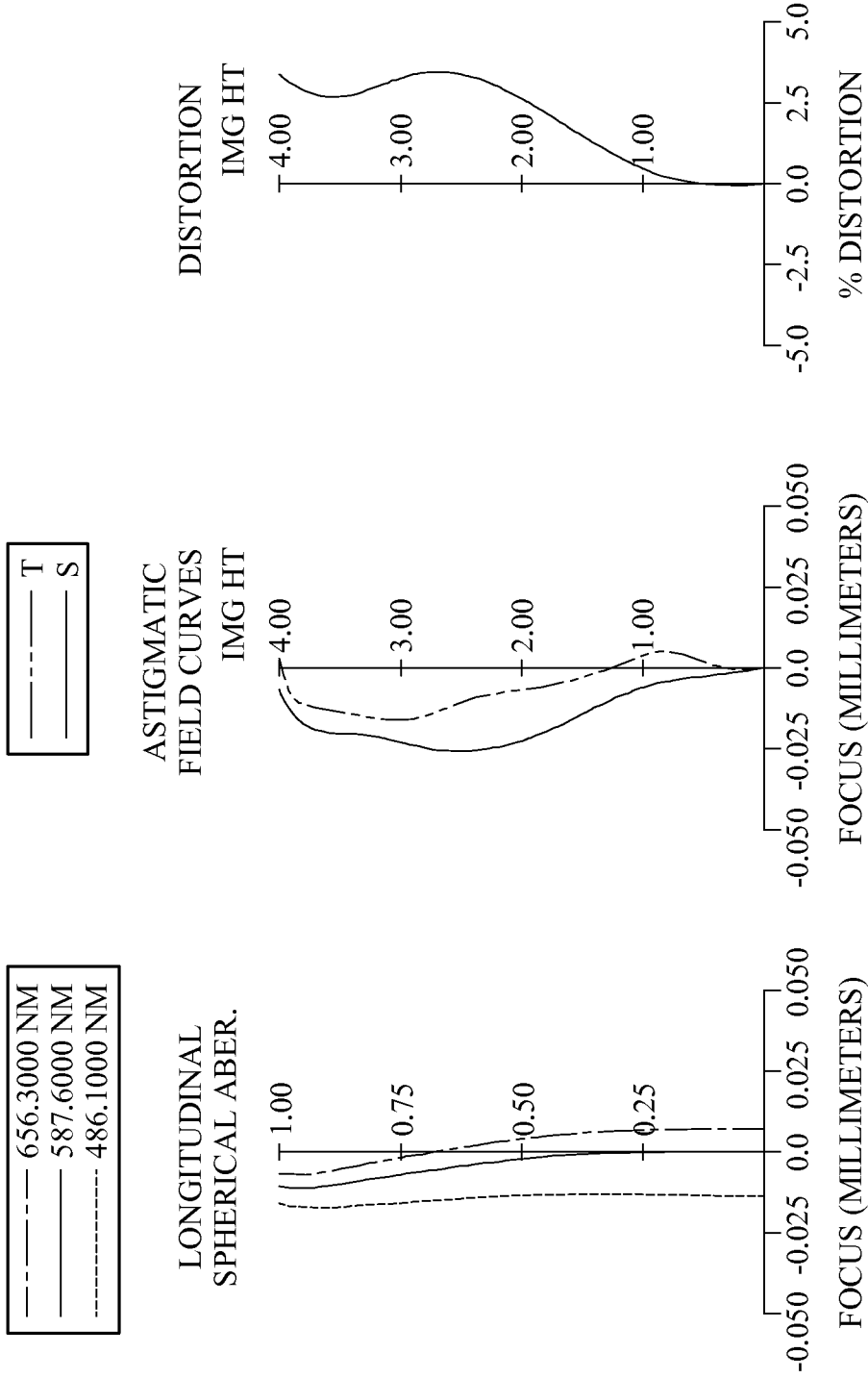

FIG.12

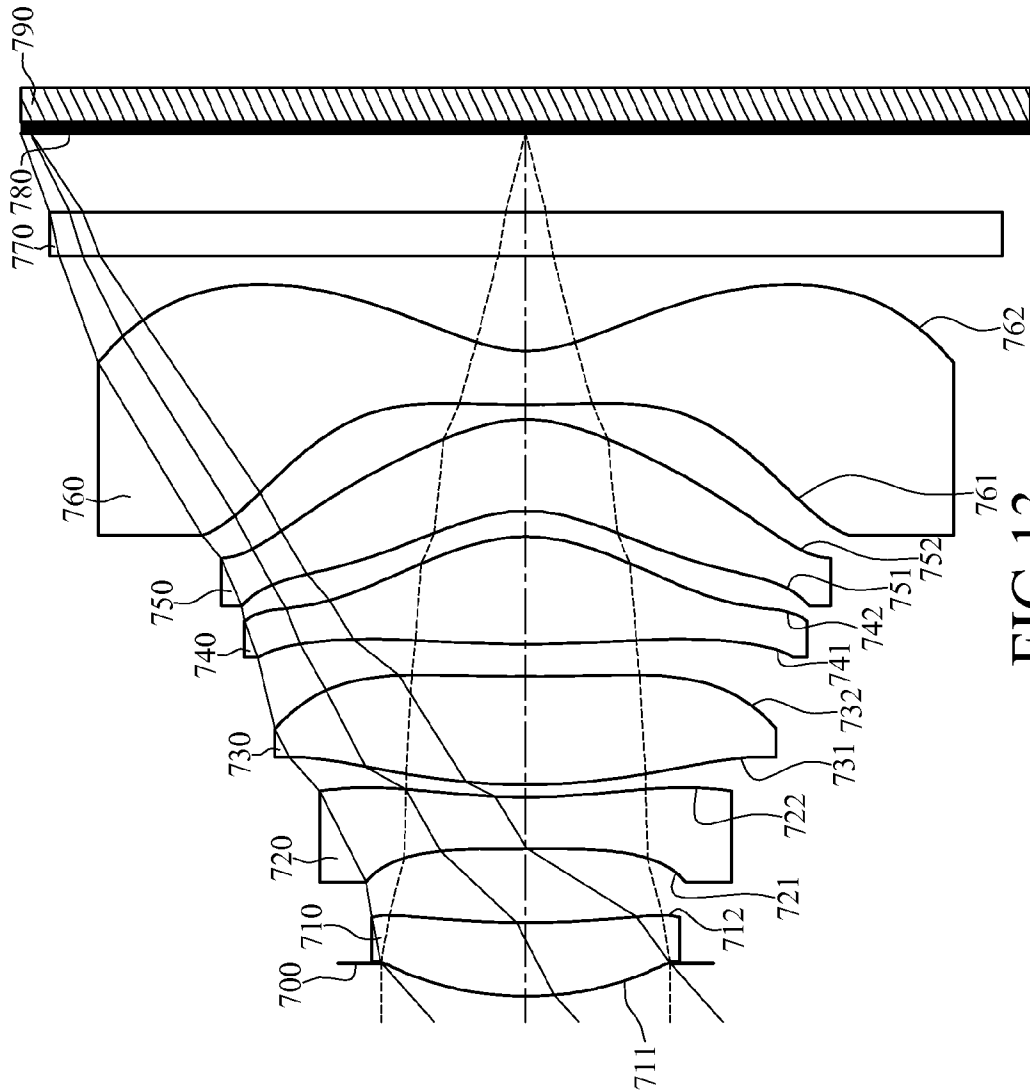

FIG. 13

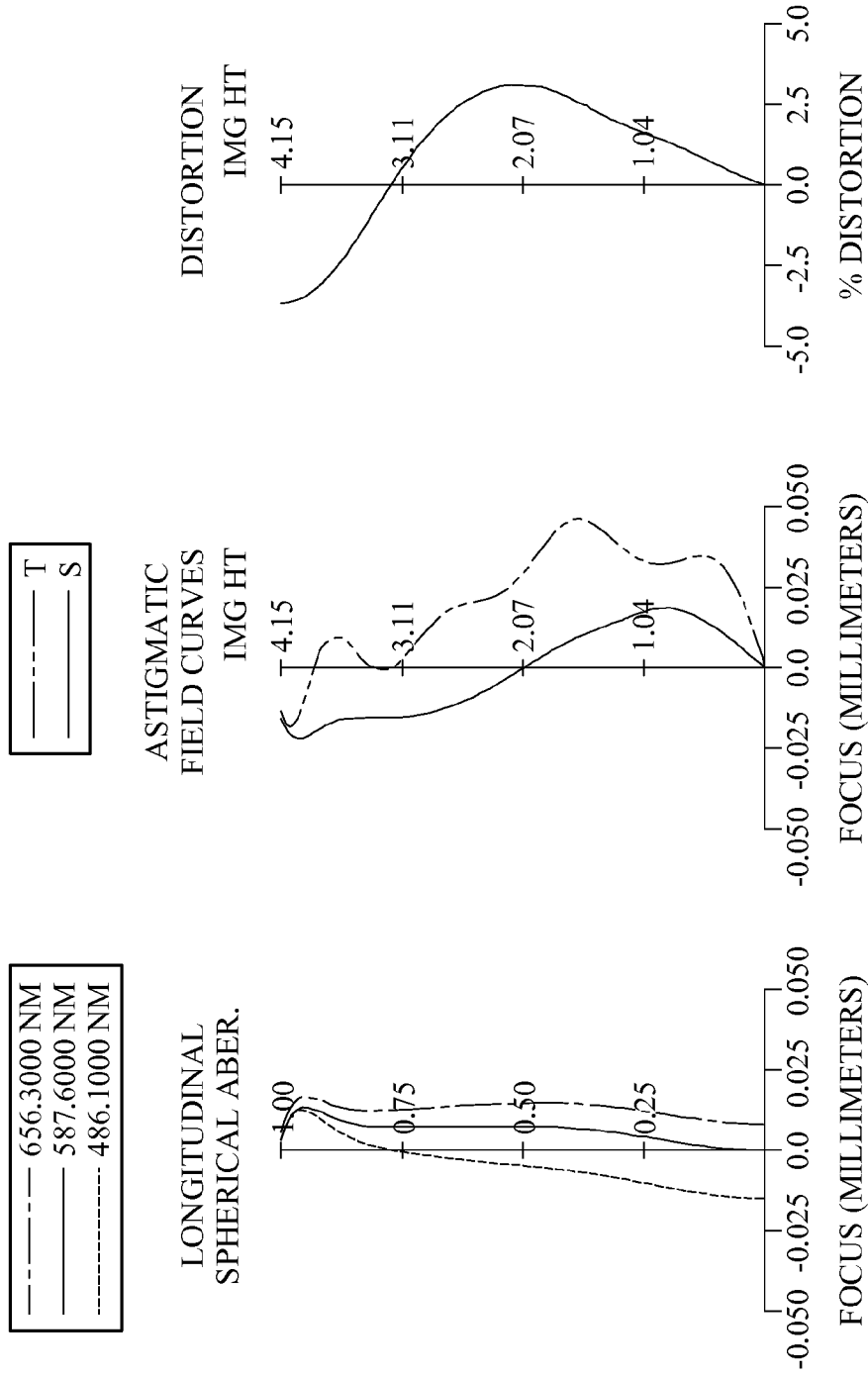

FIG. 14

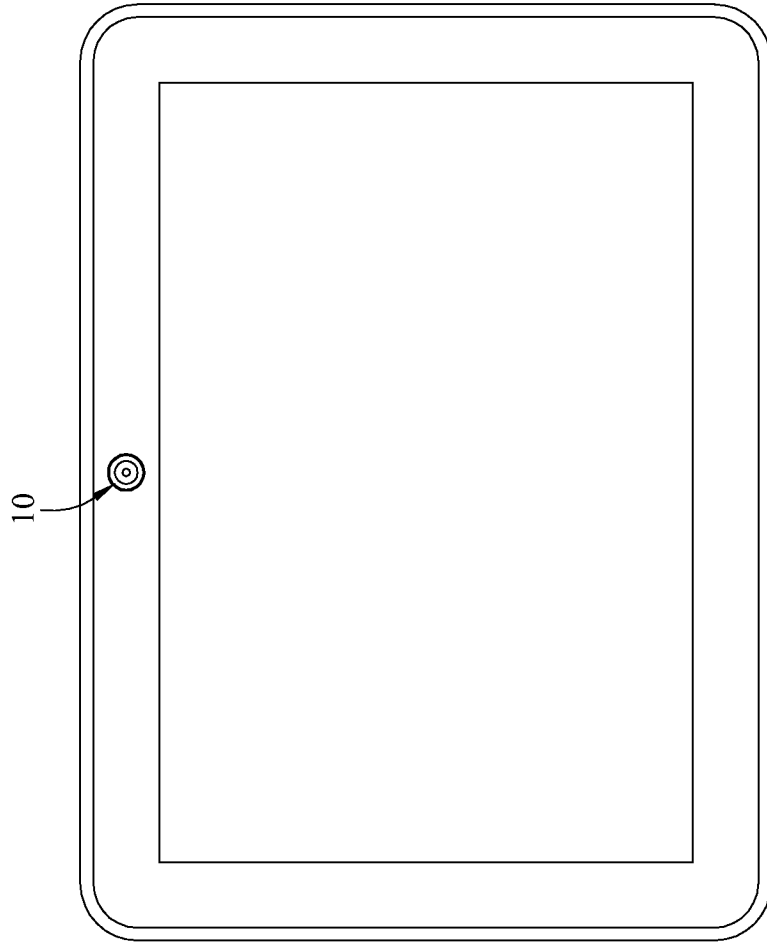

FIG. 16

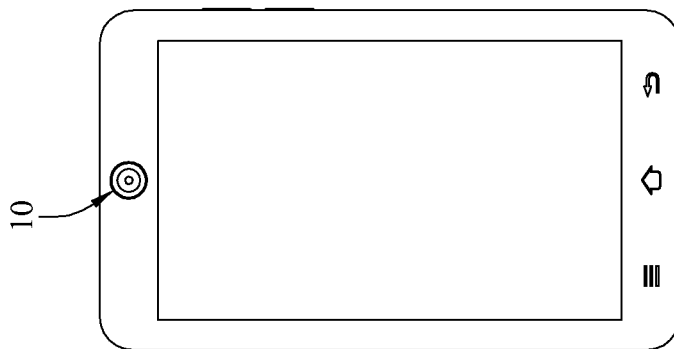

FIG. 15

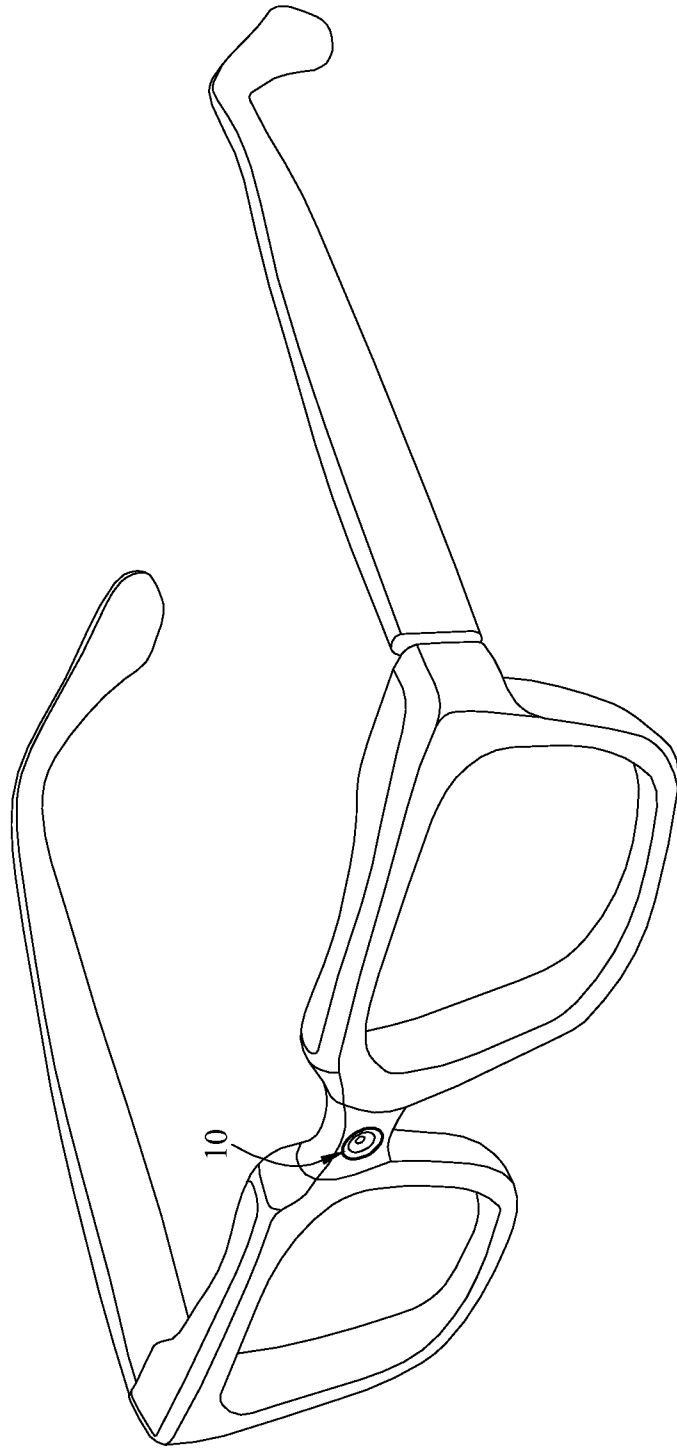

FIG.17

**PHOTOGRAPHING OPTICAL LENS
ASSEMBLY, IMAGE CAPTURING UNIT AND
MOBILE DEVICE**

RELATED APPLICATIONS

This application claims priority to Taiwan Application Serial Number 103110739, filed Mar. 21, 2014, which is incorporated by reference herein in its entirety.

BACKGROUND

1. Technical Field

The present disclosure relates to a photographing optical lens assembly, an image capturing unit and a mobile device, more particularly to a photographing optical lens assembly and an image capturing unit applicable to a mobile device.

2. Description of Related Art

In recent years, with the popularity of mobile terminals having camera functionalities, the demand of miniaturized optical systems has been increasing. The sensor of a conventional optical system is typically a CCD (Charge-Coupled Device) or a CMOS (Complementary Metal-Oxide-Semiconductor) sensor. As the advanced semiconductor manufacturing technologies have allowed the pixel size of sensors to be reduced and compact optical systems have gradually evolved toward the field of higher megapixels, there is an increasing demand for compact optical systems featuring better image quality.

A conventional optical system employed in a portable electronic product mainly adopts a five-element lens structure. Due to the popularity of mobile terminals with high-end specifications, such as smart phones, tablet personal computers and wearable apparatus, the requirements for high resolution and image quality of present compact optical systems increase significantly. However, the conventional optical systems cannot satisfy these requirements of the compact optical systems.

Other conventional compact optical systems with six-element lens structure enhance image quality and resolution. However, in order to keep a compact optical system, the air gap in a paraxial region between the first lens element and the second lens element is extremely small. It is thereby unfavorable for assembling. Also, since the air gap between the first lens element and the second lens element is extremely small, the first lens element is easy to be in contact with the second lens element which leads to worse image quality.

SUMMARY

According to one aspect of the present disclosure, a photographing optical lens assembly includes, in order from an object side to an image side, a first lens element, a second lens element, a third lens element, a fourth lens element, a fifth lens element, and a sixth lens element. The first lens element has positive refractive power. The second lens element with negative refractive power has an object-side surface being convex in a paraxial region thereof and an image-side surface being concave in a paraxial region thereof. The third lens element has refractive power. The fourth lens element has refractive power. The fifth lens element has refractive power, and both of an object-side surface and an image-side surface of the fifth lens element are aspheric. The sixth lens element with refractive power has an image-side surface being concave in a paraxial region thereof, wherein the image-side surface of the sixth lens element has at least one inflection point, and both of an object-side surface and the image-side

surface of the sixth lens element are aspheric. The photographing optical lens assembly has a total of six lens elements with refractive power. The largest air gap in a paraxial region between any two of the first through sixth lens elements that are adjacent to each other is between the first lens element and the second lens element. When a focal length of the photographing optical lens assembly is f , a vertical distance between a non-axial critical point on the image-side surface of the sixth lens element and an optical axis is $Yc62$, a curvature radius of an image-side surface of the fourth lens element is $R8$, a curvature radius of the object-side surface of the fifth lens element is $R9$, a curvature radius of the image-side surface of the fifth lens element is $R10$, and the following conditions are satisfied:

$$0.20 < Yc62/f < 0.90;$$

$$0.40 < |f/R8|; \text{ and}$$

$$-0.30 < (R9 - R10)/(R9 + R10) < 3.00.$$

According to another aspect of the present disclosure, an image capturing unit includes the photographing optical lens assembly according to the aforementioned aspect and an image sensor, wherein the image sensor is disposed on the image side of the photographing optical lens assembly.

According to still another aspect of the present disclosure, a mobile device includes the image capturing unit according to the aforementioned aspect.

According to yet another aspect of the present disclosure, a photographing optical lens assembly includes, in order from an object side to an image side, a first lens element, a second lens element, a third lens element, a fourth lens element, a fifth lens element, and a sixth lens element. The first lens element has positive refractive power. The second lens element has refractive power. The third lens element has refractive power. The fourth lens element has refractive power. The fifth lens element has refractive power, and both of an object-side surface and an image-side surface of the fifth lens element are aspheric. The sixth lens element with negative refractive power has an image-side surface being concave in a paraxial region thereof, wherein the image-side surface of the sixth lens element has at least one inflection point, and both of an object-side surface and the image-side surface of the sixth lens element are aspheric. The photographing optical lens assembly has a total of six lens elements with refractive power. The largest air gap in a paraxial region between any two of the first through sixth lens elements that are adjacent to each other is between the first lens element and the second lens element. When a focal length of the photographing optical lens assembly is f , a curvature radius of an image-side surface of the fourth lens element is $R8$, a vertical distance between a non-axial critical point on the image-side surface of the sixth lens element and an optical axis is $Yc62$, an Abbe number of the fourth lens element is $V4$, and the following conditions are satisfied:

$$0.20 < Yc62/f < 0.90;$$

$$0.40 < |f/R8|; \text{ and}$$

$$32.0 < V4 < 70.0.$$

According to still yet another aspect of the present disclosure, an image capturing unit includes, in order from an object side to an image side, a first lens element, a second lens element, a third lens element, a fourth lens element, a fifth lens element, and a sixth lens element. The first lens element with positive refractive power has an object-side surface being convex in a paraxial region thereof. The

second lens element with negative refractive power has an image-side surface being concave in a paraxial region thereof. The third lens element has refractive power. The fourth lens element has refractive power. The fifth lens element has refractive power, and both of an object-side surface and an image-side surface of the fifth lens element are aspheric. The sixth lens element with refractive power has an object-side surface being convex in a paraxial region thereof and an image-side surface being concave in a paraxial region thereof, wherein both of the object-side surface and the image-side surface of the sixth lens element are aspheric, and the image-side surface of the sixth lens element has at least one inflection point. The photographing optical lens assembly has a total of six lens elements with refractive power. The largest air gap in a paraxial region between any two of the first through sixth lens elements that are adjacent to each other is between the first lens element and the second lens element. When a vertical distance between a non-axial critical point on the image-side surface of the sixth lens element and an optical axis is $Yc62$, a focal length of the photographing optical lens assembly is f , a curvature radius of an object-side surface of the second lens element is $R3$, a curvature radius of the image-side surface of the second lens element is $R4$, a curvature radius of the object-side surface of the fifth lens element is $R9$, a curvature radius of the image-side surface of the fifth lens element is $R10$, and the following conditions are satisfied:

$$0.20 < Yc62/f < 0.90;$$

$$-0.30 < (R9 - R10)/(R9 + R10) < 3.00; \text{ and}$$

$$0 < (R3 - R4)/(R3 + R4) < 10.00.$$

BRIEF DESCRIPTION OF THE DRAWINGS

The disclosure can be more fully understood by reading the following detailed description of the embodiments, with reference made to the accompanying drawings as follows:

FIG. 1 is a schematic view of an image capturing unit according to the 1st embodiment of the present disclosure;

FIG. 2 shows spherical aberration curves, astigmatic field curves and a distortion curve of the image capturing unit according to the 1st embodiment;

FIG. 3 is a schematic view of an image capturing unit according to the 2nd embodiment of the present disclosure;

FIG. 4 shows spherical aberration curves, astigmatic field curves and a distortion curve of the image capturing unit according to the 2nd embodiment;

FIG. 5 is a schematic view of an image capturing unit according to the 3rd embodiment of the present disclosure;

FIG. 6 shows spherical aberration curves, astigmatic field curves and a distortion curve of the image capturing unit according to the 3rd embodiment;

FIG. 7 is a schematic view of an image capturing unit according to the 4th embodiment of the present disclosure;

FIG. 8 shows spherical aberration curves, astigmatic field curves and a distortion curve of the image capturing unit according to the 4th embodiment;

FIG. 9 is a schematic view of an image capturing unit according to the 5th embodiment of the present disclosure;

FIG. 10 shows spherical aberration curves, astigmatic field curves and a distortion curve of the image capturing unit according to the 5th embodiment;

FIG. 11 is a schematic view of an image capturing unit according to the 6th embodiment of the present disclosure;

FIG. 12 shows spherical aberration curves, astigmatic field curves and a distortion curve of the image capturing unit according to the 6th embodiment;

FIG. 13 is a schematic view of an image capturing unit according to the 7th embodiment of the present disclosure;

FIG. 14 shows spherical aberration curves, astigmatic field curves and a distortion curve of the image capturing unit according to the 7th embodiment;

FIG. 15 shows a mobile device according to an embodiment;

FIG. 16 shows a mobile device according to an embodiment; and

FIG. 17 shows a mobile device according to an embodiment.

DETAILED DESCRIPTION

An photographing optical lens assembly includes, in order from an object side to an image side, a first lens element, a second lens element, a third lens element, a fourth lens element, a fifth lens element, and a sixth lens element. The photographing optical lens assembly has a total of six lens elements with refractive power.

The first lens element has positive refractive power, so that it provides the photographing optical lens assembly with the positive refractive power as it needs to be to reduce the total track length thereof. The first lens element can have an object-side surface being convex in a paraxial region thereof and an image-side surface being concave in a paraxial region thereof, so that it is favorable for minimizing the refractive degree of the incident light so as to correct aberrations.

The second lens element can have negative refractive power, so that it is favorable for correcting the aberration from the first lens element. The second lens element can have an object-side surface being convex in a paraxial region thereof and an image-side surface being concave in a paraxial region thereof. Therefore, it is favorable for correcting the astigmatism and increasing the image quality.

The third lens element with refractive power can have an object-side surface being convex in a paraxial region thereof, and the object-side surface of the third lens element can have at least one concave shape in an off-axis region thereof. Therefore, it is favorable for effectively reducing the incident angle of the light projecting onto an image sensor, so that it is favorable for improving the responding sensitivity of the image sensor to further correct the aberration of the off-axis.

The fourth lens element can have positive refractive power so that it is favorable for reducing the photosensitivity of photographing optical lens assembly by balancing with the positive refractive power of the first lens element. The fourth lens element can have an object-side surface being concave in a paraxial region thereof and an image-side surface being convex in a paraxial region thereof. Therefore, it is favorable for correcting the astigmatism.

The fifth lens element can have positive refractive power. The fifth lens element can have an object-side surface being concave in a paraxial region thereof. The fifth lens element has an image-side surface being convex in a paraxial region thereof. Therefore, it is favorable for reducing the total track length thereof, and further keeping the photographing optical lens assembly compact. Moreover, both of the object-side surface and the image-side surface of the fifth lens element are aspheric.

The sixth lens element can have negative refractive power. The sixth lens element can have an object-side surface being convex in a paraxial region thereof, and the object-side surface of the sixth lens element has at least one concave shape in an off-axis region thereof. The sixth lens element has an image-side surface being concave in a paraxial region thereof. Therefore, it is favorable for the principal point of the photo-

graphing optical lens assembly being positioned away from the image side and reducing the back focal length of the photographing optical lens assembly so as to keep a compact size thereof. In addition, the image-side surface of the sixth lens element has at least one inflection point. Therefore, it is favorable for effectively reducing the incident angle of the light projecting onto the image sensor, so that it is favorable for improving the responding sensitivity of the image sensor to further correct the aberration of the off-axis. Both of the object-side surface and the image-side surface of the sixth lens element are aspheric.

When a vertical distance between a non-axial critical point on the image-side surface of the sixth lens element and an optical axis is $Yc62$, and a focal length of the photographing optical lens assembly is f , the following condition is satisfied: $0.20 < Yc62/f < 0.90$. Therefore, it is favorable for effectively reducing the incident angle of the light of the off-axis on the image sensor so as to increase the responding efficiency of the image sensor.

When the focal length of the photographing optical lens assembly is f , and a curvature radius of the image-side surface of the fourth lens element is $R8$, the following condition is satisfied: $0.40 < |f/R8|$. Therefore, it is favorable for correcting the Petzval Sum of the photographing optical lens assembly so as to improve the flatness of the image plane. Preferably, the following condition is satisfied: $0.90 < |f/R8|$.

When a curvature radius of the object-side surface of the fifth lens element is $R9$, a curvature radius of the image-side surface of the fifth lens element is $R10$, and the following condition is satisfied: $-0.30 < (R9 - R10)/(R9 + R10) < 3.00$. Therefore, the curvature of the fifth lens element is more proper for correcting the high-order aberration.

When an Abbe number of the fourth lens element is $V4$, the following condition is satisfied: $32.0 < V4 < 70.0$. Therefore, it is favorable for correcting the chromatic aberration of the photographing optical lens assembly so as to improve the resolving power thereof.

When a curvature radius of the object-side surface of the second lens element is $R3$, a curvature radius of the image-side surface of the second lens element is $R4$, and the following condition is satisfied: $0 < (R3 - R4)/(R3 + R4) < 10.00$. Therefore, it is favorable for controlling the geometric aberration of the photographing optical lens assembly.

When the curvature radius of the image-side surface of the fifth lens element is $R10$, a curvature radius of the image-side surface of the sixth lens element is $R12$, a maximum image height of the photographing optical lens assembly (half of a diagonal length of an effective photosensitive area of the image sensor) is $ImgH$, and the following condition is satisfied: $0 < (|R10| + |R12|)/ImgH < 1.20$. Therefore, it is favorable for maintaining a proper back focal length and keeping the photographing optical lens assembly compact.

When an axial distance between the first lens element and the second lens element is $T12$, a central thickness of the second lens element is $CT2$, and the following condition is satisfied: $1.00 < T12/CT2 < 3.50$. Therefore, it provides favorable moldability and homogeneity for the lens elements so as to increase the manufacturing yield rate of the photographing optical lens assembly.

When the axial distance between the first lens element and the second lens element is $T12$, an axial distance between the second lens element and the third lens element is $T23$, and the following condition is satisfied: $1.00 < T12/T23 < 1.80$. Therefore, it is favorable for improving the manufacturability of the photographing optical lens assembly.

When the curvature radius of the image-side surface of the sixth lens element is $R12$, the focal length of the photograph-

ing optical lens assembly is f , and the following condition is satisfied: $0 < R12/f < 1.0$. Therefore, the principal point of the photographing optical lens assembly can be positioned away from the image side of the photographing optical lens assembly to reduce the back focal length. It is thereby favorable for keeping the photographing optical lens assembly compact.

When an axial distance between the object-side surface of the first lens element and an image plane is TL , the maximum image height of the photographing optical lens assembly is $ImgH$, and the following condition is satisfied: $TL/ImgH < 2.00$. Therefore, it is favorable for applying the photographing optical lens assembly to the mobile device.

When the focal length of the photographing optical lens assembly is f , a focal length of the fourth lens element is $f4$, and the following condition is satisfied: $0.50 < f/f4 < 2.50$. Therefore, it is favorable for correcting aberration and image distortion and reducing the photosensitivity of photographing optical lens assembly.

When the axial distance between the first lens element and the second lens element is $T12$, an axial distance between the third lens element and the fourth lens element is $T34$, and the following condition is satisfied: $1.00 < T12/T34 < 2.30$. Therefore, it is favorable for assembling the lens elements by properly adjusting the axial distances between the aforementioned lens elements so as to reduce the total track length. It is thereby favorable for keeping the size compact to be applied to mobile devices.

When the axial distance between the third lens element and the fourth lens element is $T34$, an axial distance between the fourth lens element and the fifth lens element is $T45$, and the following condition is satisfied: $0 < T45/T34 < 1.50$. Therefore, it is favorable for assembling the lens elements and therefore improving the manufacturing yield rate of the photographing optical lens assembly.

There is an air gap in a paraxial region between any two of the first lens element, the second lens element, the third lens element, the fourth lens element, the fifth lens element and the sixth lens element that are adjacent to each other. Therefore, it is favorable for assembling the aspheric lens elements and reducing the assembly difficulties. In particular, the largest air gap in a paraxial region between any two of the first through sixth lens elements that are adjacent to each other is between the first lens element and the second lens element. Therefore, it is favorable for assembling the lens elements by adjusting the axial distances between every lens element. In particular, it is favorable for the first lens element avoiding being in contact with the second lens element by designing the largest air gap in a paraxial region between the first lens element and the second lens element. Moreover, it is also favorable for disposing additional optical components such as actuator, shutter and filter.

According to the photographing optical lens assembly of the present disclosure, a critical point is a non-axial point of the lens surface where its tangent is perpendicular to an optical axis.

According to the photographing optical lens assembly of the present disclosure, the lens elements thereof can be made of glass or plastic material. When the lens elements are made of glass material, the distribution of the refractive power of the photographing optical lens assembly may be more flexible to design. When the lens elements are made of plastic material, the manufacturing cost can be effectively reduced. Furthermore, surfaces of each lens element can be arranged to be aspheric, since the aspheric surface of the lens element is easy to form a shape other than spherical surface so as to have more controllable variables for eliminating the aberration thereof, and to further decrease the required number of the

lens elements. Therefore, the total track length of the photographing optical lens assembly can also be reduced.

According to the photographing optical lens assembly of the present disclosure, each of an object-side surface and an image-side surface has a paraxial region and an off-axis region. The paraxial region refers to the region of the surface where light rays travel close to the optical axis, and the off-axis region refers to the region of the surface away from the paraxial region. Particularly, when the lens element has a convex surface, it indicates that the surface is convex in the paraxial region thereof; when the lens element has a concave surface, it indicates that the surface is concave in the paraxial region thereof.

According to the photographing optical lens assembly of the present disclosure, the photographing optical lens assembly can include at least one stop, such as an aperture stop, a glare stop or a field stop. Said glare stop or said field stop is for eliminating the stray light and thereby improving the image resolution thereof.

According to the photographing optical lens assembly of the present disclosure, an aperture stop can be configured as a front stop or a middle stop. A front stop disposed between an imaged object and the first lens element can provide a longer distance between an exit pupil of the photographing optical lens assembly and the image plane and thereby improves the image-sensing efficiency of an image sensor. A middle stop disposed between the first lens element and the image plane is favorable for enlarging the field of view of the photographing optical lens assembly and thereby provides a wider field of view for the same.

According to the present disclosure, an image capturing unit is provided. The image capturing unit includes the photographing optical lens assembly according to the aforementioned photographing optical lens assembly of the present disclosure, and an image sensor, wherein the image sensor is disposed on the image side of the aforementioned photographing optical lens assembly, that is, the image sensor can be disposed on or near an image plane of the aforementioned photographing optical lens assembly. In some embodiments, the image capturing unit can further include a barrel member, a holding member or a combination thereof.

In FIG. 15, FIG. 16 and FIG. 17, an image capturing device 10 may be installed in, but not limited to, a mobile terminal, including a smart phone (FIG. 15), a tablet personal computer (FIG. 16) or a wearable device (FIG. 17). The three exemplary figures of different kinds of mobile terminal are only exemplary for showing the image capturing device of present disclosure installing in a mobile terminal and is not limited thereto. In some embodiments, the mobile terminal can further include, but not limited to, a display, a control unit, a random access memory unit (RAM), a read only memory unit (ROM) or a combination thereof.

According to the photographing optical lens assembly of the present disclosure, the photographing optical lens assembly can be optionally applied to moving focus optical systems. Furthermore, the photographing optical lens assembly is featured with good correction ability and high image quality, and can be applied to 3D (three-dimensional) image capturing applications, in products such as digital cameras, mobile devices, digital tablets, wearable devices and other mobile terminals. According to the above description of the present disclosure, the following specific embodiments are provided for further explanation.

1st Embodiment

FIG. 1 is a schematic view of an image capturing unit according to the 1st embodiment of the present disclosure. FIG. 2 shows, in order from left to right, spherical aberration curves, astigmatic field curves and a distortion curve of the

image capturing unit according to the 1st embodiment. In FIG. 1, the image capturing unit includes the photographing optical lens assembly (its reference numeral is omitted) of the present disclosure and an image sensor 190. The photographing optical lens assembly includes, in order from an object side to an image side, a first lens element 110, an aperture stop 100, a second lens element 120, a third lens element 130, a fourth lens element 140, a fifth lens element 150, a sixth lens element 160, an IR-cut filter 170 and an image plane 180, wherein the photographing optical lens assembly has a total of six lens elements (110-160) with refractive power.

The first lens element 110 with positive refractive power has an object-side surface 111 being convex in a paraxial region thereof and an image-side surface 112 being concave in a paraxial region thereof. The first lens element 110 is made of plastic material and has the object-side surface 111 and the image-side surface 112 being both aspheric.

The second lens element 120 with negative refractive power has an object-side surface 121 being convex in a paraxial region thereof and an image-side surface 122 being concave in a paraxial region thereof. The second lens element 120 is made of plastic material and has the object-side surface 121 and the image-side surface 122 being both aspheric.

The third lens element 130 with positive refractive power has an object-side surface 131 being convex in a paraxial region thereof and an image-side surface 132 being concave in a paraxial region thereof. The object-side surface 131 of the third lens element 130 has at least one concave shape in an off-axis region thereof. The third lens element 130 is made of plastic material and has the object-side surface 131 and the image-side surface 132 being both aspheric.

The fourth lens element 140 with positive refractive power has an object-side surface 141 being concave in a paraxial region thereof and an image-side surface 142 being convex in a paraxial region thereof. The fourth lens element 140 is made of plastic material and has the object-side surface 141 and the image-side surface 142 being both aspheric.

The fifth lens element 150 with positive refractive power has an object-side surface 151 being concave in a paraxial region thereof and an image-side surface 152 being convex in a paraxial region thereof. The fifth lens element 150 is made of plastic material and has the object-side surface 151 and the image-side surface 152 being both aspheric.

The sixth lens element 160 with negative refractive power has an object-side surface 161 being convex in a paraxial region thereof and an image-side surface 162 being concave in a paraxial region thereof. The object-side surface 161 of the sixth lens element 160 has at least one concave shape in an off-axis region thereof. The image-side surface 162 of the sixth lens element 160 has at least one inflection point. The sixth lens element 160 is made of plastic material and has the object-side surface 161 and the image-side surface 162 being both aspheric.

The IR-cut filter 170 is made of glass and located between the sixth lens element 160 and the image plane 180, and will not affect the focal length of the photographing optical lens assembly. The image sensor 190 is disposed on or near the image plane 180 of the photographing optical lens assembly.

The equation of the aspheric surface profiles of the aforementioned lens elements of the 1st embodiment is expressed as follows:

$$X(Y) = (Y^2/R) / (1 + \sqrt{1 - (1+k) \times (Y/R)^2}) + \sum_{i=1}^n (A_i) \times (Y^i),$$

where,

X is the relative distance between a point on the aspheric surface spaced at a distance Y from the optical axis and the tangential plane at the aspheric surface vertex on the optical axis;

Y is the vertical distance from the point on the aspheric surface to the optical axis;

R is the curvature radius;
 k is the conic coefficient; and
 Ai is the i-th aspheric coefficient, and in the embodiments,
 i may be, but is not limited to, 4, 6, 8, 10, 12, 14 and 16.

In the photographing optical lens assembly of the image capturing unit according to the 1st embodiment, when a focal length of the photographing optical lens assembly is f, an f-number of the photographing optical lens assembly is Fno, and half of a maximal field of view of the photographing optical lens assembly is HFOV, these parameters have the following values: f=3.47 mm; Fno=2.00; and HFOV=38.2 degrees.

In the photographing optical lens assembly of the image capturing unit according to the 1st embodiment, when an Abbe number of the fourth lens element 140 is V4, the following condition is satisfied: V4=55.8.

In the photographing optical lens assembly of the image capturing unit according to the 1st embodiment, when an axial distance between the first lens element 110 and the second lens element 120 is T12, a central thickness of the second lens element 120 is CT2, and the following condition is satisfied: T12/CT2=1.92.

In the photographing optical lens assembly of the image capturing unit according to the 1st embodiment, when the axial distance between the first lens element 110 and the second lens element 120 is T12, an axial distance between the second lens element 120 and the third lens element 130 is T23, and the following condition is satisfied: T12/T23=2.33.

In the photographing optical lens assembly of the image capturing unit according to the 1st embodiment, when the axial distance between the first lens element 110 and the second lens element 120 is T12, an axial distance between the third lens element 130 and the fourth lens element 140 is T34, and the following condition is satisfied: T12/T34=1.80.

In the photographing optical lens assembly of the image capturing unit according to the 1st embodiment, when the axial distance between the third lens element 130 and the fourth lens element 140 is T34, an axial distance between the fourth lens element 140 and the fifth lens element 150 is T45, and the following condition is satisfied: T45/T34=0.14.

In the photographing optical lens assembly of the image capturing unit according to the 1st embodiment, when the focal length of the photographing optical lens assembly is f, a curvature radius of an image-side surface 142 of the fourth lens element 140 is R8, and the following condition is satisfied: |f/R8|=2.28.

In the photographing optical lens assembly of the image capturing unit according to the 1st embodiment, when

wherein a curvature radius of the image-side surface 162 of the sixth lens element 160 is R12, the focal length of the photographing optical lens assembly is f, and the following condition is satisfied: R12/f=0.17.

In the photographing optical lens assembly of the image capturing unit according to the 1st embodiment, when a curvature radius of the object-side surface 121 of the second lens element 120 is R3, a curvature radius of the image-side surface 122 of the second lens element 120 is R4, and the following condition is satisfied: (R3-R4)/(R3+R4)=0.24.

In the photographing optical lens assembly of the image capturing unit according to the 1st embodiment, when a curvature radius of the object-side surface 151 of the fifth lens element 150 is R9, a curvature radius of the image-side surface of the fifth lens element 150 is R10, and the following condition is satisfied: (R9-R10)/(R9+R10)=0.68

In the photographing optical lens assembly of the image capturing unit according to the 1st embodiment, when the curvature radius of the image-side surface 152 of the fifth lens element 150 is R10, the curvature radius of the image-side surface 162 of the sixth lens element 160 is R12, a maximum image height of the photographing optical lens assembly is ImgH, and the following condition is satisfied: (|R10|+|R12|)/ImgH=0.46.

In the photographing optical lens assembly of the image capturing unit according to the 1st embodiment, when the focal length of the photographing optical lens assembly is f, a focal length of the fourth lens element 140 is f4, and the following condition is satisfied: f/f4=0.75.

In the photographing optical lens assembly of the image capturing unit according to the 1st embodiment, when a vertical distance between a non-axial critical point on the image-side surface 162 of the sixth lens element 160 and the optical axis is Yc62, the focal length of the photographing optical lens assembly is f, and the following condition is satisfied: Yc62/f=0.50.

In the photographing optical lens assembly of the image capturing unit according to the 1st embodiment, when an axial distance between the object-side surface 111 of the first lens element 110 and an image plane 180 is TL, the maximum image height of the photographing optical lens assembly is ImgH, and the following condition is satisfied: TL/ImgH=1.79.

The detailed optical data of the 1st embodiment are shown in Table 1 and the aspheric surface data are shown in Table 2 below.

TABLE 1

1st Embodiment							
f = 3.47 mm, Fno = 2.00, HFOV = 38.2 deg.							
Surface #		Curvature Radius	Thickness	Material	Index	Abbe #	Focal Length
0	Object	Plano	Infinity				
1	Lens 1	2.055 (ASP)	0.436	Plastic	1.535	56.3	5.72
2		5.815 (ASP)	0.064				
3	Ape. Stop	Plano	0.397				
4	Lens 2	3.238 (ASP)	0.240	Plastic	1.650	21.4	-8.45
5		1.977 (ASP)	0.198				
6	Lens 3	2.659 (ASP)	0.475	Plastic	1.530	55.8	10.22
7		4.901 (ASP)	0.256				
8	Lens 4	-3.584 (ASP)	0.475	Plastic	1.530	55.8	4.62
9		-1.521 (ASP)	0.035				
10	Lens 5	-3.811 (ASP)	0.664	Plastic	1.530	55.8	1.55
11		-0.715 (ASP)	0.085				
12	Lens 6	7.371 (ASP)	0.274	Plastic	1.535	55.7	-1.19

TABLE 1-continued

1st Embodiment							
f = 3.47 mm, Fno = 2.00, HFOV = 38.2 deg.							
Surface #		Curvature Radius	Thickness	Material	Index	Abbe #	Focal Length
13		0.578 (ASP)	0.800				
14	IR-cut filter	Plano	0.250	Glass	1.517	64.2	—
15		Plano	0.360				
16	Image	Plano	—				

Note: Reference wavelength is 587.6 nm (d-line).

TABLE 2

Aspheric Coefficients						
Surface #	1	2	4	5	6	7
k =	2.0194E+00	-1.0000E+00	-1.8101E+01	-9.6709E+00	-1.3790E+01	-2.0000E+01
A4 =	-3.7725E-02	-3.1350E-02	-1.2624E-01	-5.3398E-02	9.2669E-03	-1.9461E-02
A6 =	-3.2839E-03	-3.0835E-02	-1.1921E-02	-2.1497E-02	-7.0849E-03	-1.6379E-02
A8 =	-3.7996E-02	3.3825E-02	-4.2324E-02	5.5818E-03	1.2561E-02	8.3751E-03
A10 =	-3.4633E-03	-4.2154E-02	3.5140E-02	-1.3634E-02	-1.3439E-02	-3.5147E-03
A12 =	2.4365E-02	-3.2997E-02	-4.3704E-02	1.0261E-02	3.1719E-03	-3.1053E-04
A14 =	-2.9040E-02	3.4261E-02	2.4948E-02	-1.2555E-03	-1.6891E-04	—
Surface #	8	9	10	11	12	13
k =	4.2021E+00	-1.9404E+00	-2.4980E-01	-5.6670E+00	-1.0000E+00	-4.8260E+00
A4 =	2.2335E-02	1.4684E-02	9.6460E-03	-7.4826E-02	-8.9919E-02	-5.3155E-02
A6 =	7.5734E-03	3.2847E-03	3.1046E-03	3.2747E-02	7.9325E-03	1.2765E-02
A8 =	-1.6317E-02	-2.8133E-04	-2.1596E-03	-9.8268E-03	4.7429E-03	-2.1281E-03
A10 =	1.5897E-02	2.0961E-04	-1.2710E-03	3.8125E-03	-8.4528E-04	1.6626E-04
A12 =	-4.2519E-03	3.8732E-04	-4.8945E-04	-4.6438E-04	-9.9916E-05	-6.4657E-06
A14 =	3.3195E-04	—	3.3994E-05	-9.8855E-05	2.0300E-05	2.3319E-07

In Table 1, the curvature radius, the thickness and the focal length are shown in millimeters (mm). Surface numbers 0-16 represent the surfaces sequentially arranged from the object-side to the image-side along the optical axis. In Table 2, k represents the conic coefficient of the equation of the aspheric surface profiles. A4-A14 represent the aspheric coefficients ranging from the 4th order to the 14th order. The tables presented below for each embodiment are the corresponding schematic parameter and aberration curves, and the definitions of the tables are the same as Table 1 and Table 2 of the 1st embodiment. Therefore, an explanation in this regard will not be provided again.

2nd Embodiment

FIG. 3 is a schematic view of an image capturing unit according to the 2nd embodiment of the present disclosure. FIG. 4 shows, in order from left to right, spherical aberration curves, astigmatic field curves and a distortion curve of the image capturing unit according to the 2nd embodiment. In FIG. 3, the image capturing unit includes the photographing optical lens assembly (its reference numeral is omitted) of the present disclosure and an image sensor 290. The photographing optical lens assembly includes, in order from an object side to an image side, a first lens element 210, an aperture stop 200, a second lens element 220, a third lens element 230, a fourth lens element 240, a fifth lens element 250, a sixth lens element 260, an IR-cut filter 270 and an image plane 280, wherein the photographing optical lens assembly has a total of six lens elements (210-260) with refractive power.

35

The first lens element 210 with positive refractive power has an object-side surface 211 being convex in a paraxial region thereof and an image-side surface 212 being concave in a paraxial region thereof. The first lens element 210 is made of plastic material and has the object-side surface 211 and the image-side surface 212 being both aspheric.

40

The second lens element 220 with negative refractive power has an object-side surface 221 being convex in a paraxial region thereof and an image-side surface 222 being concave in a paraxial region thereof. The second lens element 220 is made of plastic material and has the object-side surface 221 and the image-side surface 222 being both aspheric.

45

50

The third lens element 230 with negative refractive power has an object-side surface 231 being convex in a paraxial region thereof and an image-side surface 232 being concave in a paraxial region thereof. The object-side surface 231 of the third lens element 230 has at least one concave shape in an off-axis region thereof. The third lens element 230 is made of plastic material and has the object-side surface 231 and the image-side surface 232 being both aspheric.

55

60

The fourth lens element 240 with positive refractive power has an object-side surface 241 being convex in a paraxial region thereof and an image-side surface 242 being convex in a paraxial region thereof. The fourth lens element 240 is made of plastic material and has the object-side surface 241 and the image-side surface 242 being both aspheric.

65

The fifth lens element 250 with positive refractive power has an object-side surface 251 being concave in a paraxial region thereof and an image-side surface 252 being convex in

13

a paraxial region thereof. The fifth lens element **250** is made of plastic material and has the object-side surface **251** and the image-side surface **252** being both aspheric.

The sixth lens element **260** with negative refractive power has an object-side surface **261** being convex in a paraxial region thereof and an image-side surface **262** being concave in a paraxial region thereof. The object-side surface **261** of the sixth lens element **260** has at least one concave shape in an off-axis region thereof. The image-side surface **262** of the sixth lens element **260** has at least one inflection point. The sixth lens element **260** is made of plastic material and has the object-side surface **261** and the image-side surface **262** being both aspheric.

The IR-cut filter **270** is made of glass and located between the sixth lens element **260** and the image plane **280**, and will not affect the focal length of the photographing optical lens assembly. The image sensor **290** is disposed on or near the image plane **280** of the photographing optical lens assembly.

The detailed optical data of the 2nd embodiment are shown in Table 3 and the aspheric surface data are shown in Table 4 below.

TABLE 3

2nd Embodiment							
f = 4.82 mm, Fno = 2.20, HFOV = 39.8 deg.							
Surface #		Curvature Radius	Thickness	Material	Index	Abbe #	Focal Length
0	Object	Plano	Infinity				
1	Lens 1	2.615 (ASP)	0.570	Plastic	1.544	55.9	7.58
2		6.603 (ASP)	0.110				
3	Ape. Stop	Plano	0.463				
4	Lens 2	4.523 (ASP)	0.364	Plastic	1.650	21.4	-17.67
5		3.142 (ASP)	0.441				
6	Lens 3	4.377 (ASP)	0.404	Plastic	1.544	55.9	-137.56
7		4.001 (ASP)	0.207				
8	Lens 4	169.595 (ASP)	0.788	Plastic	1.544	55.9	2.93
9		-1.607 (ASP)	0.288				
10	Lens 5	-1.520 (ASP)	0.728	Plastic	1.544	55.9	7.04
11		-1.272 (ASP)	0.279				
12	Lens 6	12.601 (ASP)	0.450	Plastic	1.535	55.7	-2.62
13		1.247 (ASP)	0.700				
14	IR-cut filter	Plano	0.370	Glass	1.517	64.2	—
15		Plano	0.549				
16	Image	Plano	—				

Note: Reference wavelength is 587.6 nm (d-line).

TABLE 4

Aspheric Coefficients						
Surface #	1	2	4	5	6	7
k =	1.0744E+00	-1.0000E+00	-1.5187E+01	-6.9369E+00	-2.0000E+01	-1.7338E+01
A4 =	-7.8194E-03	-1.1740E-02	-4.9118E-02	-3.0000E-02	1.5168E-03	-3.0542E-03
A6 =	7.6690E-04	-4.2235E-04	-6.9412E-03	-5.5635E-03	4.2342E-04	-1.8491E-03
A8 =	-2.0448E-03	8.7266E-04	-4.1732E-03	1.4667E-03	8.9049E-04	3.3753E-04
A10 =	-2.6932E-04	-1.4940E-03	1.9325E-03	-9.1372E-05	-3.9118E-04	-5.3834E-05
A12 =	7.9096E-04	-2.9129E-04	2.9683E-04	6.1184E-05	4.5066E-05	4.9765E-06
A14 =	-4.6084E-04	4.3524E-05	-3.8695E-04	-8.5484E-06	-1.9520E-06	—
Surface #	8	9	10	11	12	13
k =	-1.0953E+03	-3.4591E+00	-4.6565E+00	-4.5963E+00	-1.0000E+00	-5.2235E+00
A4 =	-2.2986E-03	1.0686E-02	2.6607E-02	-1.7951E-02	-5.6727E-02	-2.6766E-02
A6 =	5.2941E-04	2.4739E-03	-4.5253E-04	4.6034E-03	1.8753E-03	3.7290E-03
A8 =	-8.2626E-04	2.1023E-04	-1.0396E-03	-8.1033E-04	9.0096E-04	-3.7094E-04
A10 =	5.0398E-04	-1.0201E-05	7.4467E-05	1.6355E-04	-4.0936E-05	1.6742E-05
A12 =	-5.8274E-05	-6.2650E-06	1.5477E-05	-4.0912E-06	-5.4388E-06	-8.2782E-08
A14 =	-3.3573E-07	—	-4.3424E-06	-1.5539E-06	2.2647E-07	-1.3166E-08

14

In the 2nd embodiment, the equation of the aspheric surface profiles of the aforementioned lens elements is the same as the equation of the 1st embodiment. Also, the definitions of these parameters shown in the following table are the same as those stated in the 1st embodiment with corresponding values for the 2nd embodiment, so an explanation in this regard will not be provided again.

Moreover, these parameters can be calculated from Table 3 and Table 4 as the following values and satisfy the following conditions:

2nd Embodiment			
f [mm]	4.82	f/R8	3.00
Fno	2.20	R12/f	0.26
HFOV [deg.]	39.8	(R3-R4)/(R3 + R4)	0.18
V4	55.9	(R9-R10)/(R9 + R10)	0.09
T12/CT2	1.57	(R10 + R12)/ImgH	0.61
T12/T23	1.30	f/f4	1.65
T12/T34	2.77	Yc62/f	0.43
T45/T34	1.39	TL/ImgH	1.62

FIG. 5 is a schematic view of an image capturing unit according to the 3rd embodiment of the present disclosure. FIG. 6 shows, in order from left to right, spherical aberration curves, astigmatic field curves and a distortion curve of the image capturing unit according to the 3rd embodiment. In FIG. 5, the image capturing unit includes the photographing optical lens assembly (its reference numeral is omitted) of the present disclosure and an image sensor 390. The photographing optical lens assembly includes, in order from an object side to an image side, an aperture stop 300, a first lens element 310, a second lens element 320, a third lens element 330, a fourth lens element 340, a fifth lens element 350, a sixth lens element 360, an IR-cut filter 370 and an image plane 380, wherein the photographing optical lens assembly has a total of six lens elements (310-360) with refractive power.

The first lens element 310 with positive refractive power has an object-side surface 311 being convex in a paraxial region thereof and an image-side surface 312 being convex in a paraxial region thereof. The first lens element 310 is made of plastic material and has the object-side surface 311 and the image-side surface 312 being both aspheric.

The second lens element 320 with negative refractive power has an object-side surface 321 being convex in a paraxial region thereof and an image-side surface 322 being concave in a paraxial region thereof. The second lens element 320 is made of plastic material and has the object-side surface 321 and the image-side surface 322 being both aspheric.

The third lens element 330 with positive refractive power has an object-side surface 331 being convex in a paraxial region thereof and an image-side surface 332 being convex in a paraxial region thereof. The object-side surface 331 of the third lens element 330 has at least one concave shape in an

off-axis region thereof. The third lens element 330 is made of plastic material and has the object-side surface 331 and the image-side surface 332 being both aspheric.

The fourth lens element 340 with positive refractive power has an object-side surface 341 being concave in a paraxial region thereof and an image-side surface 342 being convex in a paraxial region thereof. The fourth lens element 340 is made of plastic material and has the object-side surface 341 and the image-side surface 342 being both aspheric.

The fifth lens element 350 with positive refractive power has an object-side surface 351 being concave in a paraxial region thereof and an image-side surface 352 being convex in a paraxial region thereof. The fifth lens element 350 is made of plastic material and has the object-side surface 351 and the image-side surface 352 being both aspheric.

The sixth lens element 360 with negative refractive power has an object-side surface 361 being convex in a paraxial region thereof and an image-side surface 362 being concave in a paraxial region thereof. The object-side surface 361 of the sixth lens element 360 has at least one concave shape in an off-axis region thereof. The image-side surface 362 of the sixth lens element 360 has at least one inflection point. The sixth lens element 360 is made of plastic material and has the object-side surface 361 and the image-side surface 362 being both aspheric.

The IR-cut filter 370 is made of glass and located between the sixth lens element 360 and the image plane 380, and will not affect the focal length of the photographing optical lens assembly. The image sensor 390 is disposed on or near the image plane 380 of the photographing optical lens assembly.

The detailed optical data of the 3rd embodiment are shown in Table 5 and the aspheric surface data are shown in Table 6 below.

TABLE 5

3rd Embodiment								
f = 5.65 mm, Fno = 2.30, HFOV = 35.5 deg.								
Surface #		Curvature Radius	Thickness	Material	Index	Abbe #	Focal Length	
0	Object	Plano	Infinity					
1	Ape. Stop	Plano	-0.189					
2	Lens 1	3.467 (ASP)	0.629	Plastic	1.535	55.7		5.99
3		-39.683 (ASP)	0.581					
4	Lens 2	10.998 (ASP)	0.300	Plastic	1.640	23.3		-6.89
5		3.114 (ASP)	0.448					
6	Lens 3	6.451 (ASP)	1.337	Plastic	1.544	55.9		7.47
7		-10.192 (ASP)	0.388					
8	Lens 4	-14.006 (ASP)	0.899	Plastic	1.544	55.9		3.85
9		-1.862 (ASP)	0.294					
10	Lens 5	-1.536 (ASP)	0.583	Plastic	1.544	55.9		18.91
11		-1.515 (ASP)	0.137					
12	Lens 6	30.806 (ASP)	0.600	Plastic	1.535	55.7		-2.73
13		1.383 (ASP)	0.700					
14	IR-cut filter	Plano	0.370	Glass	1.517	64.2		—
15		Plano	0.536					
16	Image	Plano	—					

Note: Reference wavelength is 587.6 nm (d-line).

TABLE 6

Aspheric Coefficients							
Surface #	2	3	4	5	6	7	
k =	1.0480E+00	-1.0000E+00	-1.1904E+00	-1.1176E+01	-1.9658E+01	3.0000E+00	
A4 =	-2.6030E-03	-5.5609E-04	-5.2568E-02	-8.6577E-03	7.2787E-03	-1.8297E-02	

TABLE 6-continued

Aspheric Coefficients						
A6 =	-6.7532E-04	-1.9852E-03	9.7603E-03	-3.0391E-03	-2.3420E-03	-3.4341E-03
A8 =	-8.9680E-04	-6.2811E-04	-4.3887E-03	9.3132E-04	5.4756E-04	3.8512E-04
A10 =	-2.1616E-04	-1.0917E-03	2.4766E-04	-2.2360E-04	-3.3388E-04	-2.6003E-05
A12 =	2.7591E-04	6.4625E-04	2.5230E-04	-2.4476E-05	5.4632E-05	-2.1262E-06
A14 =	1.0480E+00	-1.0000E+00	-1.1904E+00	-1.1176E+01	-1.9658E+01	—

Surface #	8	9	10	11	12	13
k =	3.0000E+00	-2.5232E+00	-2.9516E+00	-5.7473E+00	-1.0000E+00	-5.6360E+00
A4 =	-1.9164E-02	8.7480E-03	1.7710E-02	-1.6320E-02	-5.3195E-02	-2.0589E-02
A6 =	-1.3090E-03	1.7645E-03	3.2936E-04	2.5549E-03	1.5919E-03	2.8104E-03
A8 =	-9.1876E-04	1.4870E-04	-9.2931E-04	-9.6494E-04	8.3764E-04	-2.6116E-04
A10 =	4.8583E-04	-6.7478E-06	8.9281E-05	1.7243E-04	-4.4017E-05	1.4001E-05
A12 =	-5.8322E-05	-9.4184E-06	1.6135E-05	-5.3678E-07	-4.9182E-06	-4.3605E-07
A14 =	-4.1504E-07	—	-2.6807E-06	-7.8360E-07	3.8096E-07	5.1237E-09

In the 3rd embodiment, the equation of the aspheric surface profiles of the aforementioned lens elements is the same as the equation of the 1st embodiment. Also, the definitions of these parameters shown in the following table are the same as those stated in the 1st embodiment with corresponding values for the 3rd embodiment, so an explanation in this regard will not be provided again.

Moreover, these parameters can be calculated from Table 5 and Table 6 as the following values and satisfy the following conditions:

3rd Embodiment		
f [mm]	5.65	f/R8
Fno	2.30	R12/f
HFOV [deg.]	35.5	(R3-R4)/(R3 + R4)
V4	55.9	(R9-R10)/(R9 + R10)
T12/CT2	1.94	(R10 + R12)/ImgH
T12/T23	1.30	f/f4
T12/T34	1.50	Ye62/f
T45/T34	0.76	TL/ImgH

4th Embodiment

FIG. 7 is a schematic view of an image capturing unit according to the 4th embodiment of the present disclosure. FIG. 8 shows, in order from left to right, spherical aberration curves, astigmatic field curves and a distortion curve of the image capturing unit according to the 4th embodiment. In FIG. 7, the image capturing unit includes the photographing optical lens assembly (its reference numeral is omitted) of the present disclosure and an image sensor 490. The photographing optical lens assembly includes, in order from an object side to an image side, an aperture stop 400, a first lens element 410, a second lens element 420, a third lens element 430, a fourth lens element 440, a fifth lens element 450, a sixth lens element 460, an IR-cut filter 470 and an image plane 480, wherein the photographing optical lens assembly has a total of six lens elements (410-460) with refractive power.

The first lens element 410 with positive refractive power has an object-side surface 411 being convex in a paraxial region thereof and an image-side surface 412 being concave in a paraxial region thereof. The first lens element 410 is made of plastic material and has the object-side surface 411 and the image-side surface 412 being both aspheric.

The second lens element 420 with negative refractive power has an object-side surface 421 being convex in a paraxial region thereof and an image-side surface 422 being concave in a paraxial region thereof. The second lens element 420 is made of plastic material and has the object-side surface 421 and the image-side surface 422 being both aspheric.

The third lens element 430 with positive refractive power has an object-side surface 431 being convex in a paraxial region thereof and an image-side surface 432 being convex in a paraxial region thereof. The object-side surface 431 of the third lens element 430 has at least one concave shape in an off-axis region thereof. The third lens element 430 is made of plastic material and has the object-side surface 431 and the image-side surface 432 being both aspheric.

The fourth lens element 440 with positive refractive power has an object-side surface 441 being concave in a paraxial region thereof and an image-side surface 442 being convex in a paraxial region thereof. The fourth lens element 440 is made of plastic material and has the object-side surface 441 and the image-side surface 442 being both aspheric.

The fifth lens element 450 with negative refractive power has an object-side surface 451 being concave in a paraxial region thereof and an image-side surface 452 being convex in a paraxial region thereof. The fifth lens element 450 is made of plastic material and has the object-side surface 451 and the image-side surface 452 being both aspheric.

The sixth lens element 460 with negative refractive power has an object-side surface 461 being convex in a paraxial region thereof and an image-side surface 462 being concave in a paraxial region thereof. The object-side surface 461 of the sixth lens element 460 has at least one concave shape in an off-axis region thereof. The image-side surface 462 of the sixth lens element 460 has at least one inflection point. The sixth lens element 460 is made of plastic material and has the object-side surface 461 and the image-side surface 462 being both aspheric.

The IR-cut filter 470 is made of glass and located between the sixth lens element 460 and the image plane 480, and will not affect the focal length of the photographing optical lens assembly. The image sensor 490 is disposed on or near the image plane 480 of the photographing optical lens assembly.

The detailed optical data of the 4th embodiment are shown in Table 7 and the aspheric surface data are shown in Table 8 below.

TABLE 7

4th Embodiment							
f = 5.77 mm, Fno = 2.30, HFOV = 34.8 deg.							
Surface #		Curvature Radius	Thickness	Material	Index	Abbe #	Focal Length
0	Object	Plano	Infinity				
1	Ape. Stop	Plano	-0.237				
2	Lens 1	2.990 (ASP)	0.593	Plastic	1.535	55.7	6.27
3		25.799 (ASP)	0.577				
4	Lens 2	10.916 (ASP)	0.451	Plastic	1.640	23.3	-7.25
5		3.202 (ASP)	0.424				
6	Lens 3	5.780 (ASP)	1.323	Plastic	1.544	55.9	7.61
7		-13.455 (ASP)	0.385				
8	Lens 4	-14.720 (ASP)	0.981	Plastic	1.544	55.9	3.26
9		-1.622 (ASP)	0.252				
10	Lens 5	-1.424 (ASP)	0.509	Plastic	1.544	55.9	-149.65
11		-1.632 (ASP)	0.165				
12	Lens 6	242.528 (ASP)	0.534	Plastic	1.535	55.7	-2.82
13		1.497 (ASP)	0.700				
14	IR-cut filter	Plano	0.370	Glass	1.517	64.2	—
15		Plano	0.539				
16	Image	Plano	—				

Note: Reference wavelength is 587.6 nm (d-line).

TABLE 8

Aspheric Coefficients						
Surface #	2	3	4	5	6	7
k =	1.2294E+00	-1.0000E+00	3.0000E+00	-1.1621E+01	-2.0000E+01	-5.6794E+00
A4 =	-2.0424E-03	-1.1488E-03	-5.1594E-02	-6.9409E-03	8.7555E-03	-1.7746E-02
A6 =	4.4841E-04	1.1750E-03	9.8404E-03	-2.5185E-03	-2.4006E-03	-3.5093E-03
A8 =	-3.4075E-04	-8.4452E-06	-4.5900E-03	9.0462E-04	5.5049E-04	3.8098E-04
A10 =	-1.3568E-04	-1.0523E-03	4.0722E-04	-2.2545E-04	-3.1963E-04	-1.9490E-05
A12 =	2.4605E-04	6.8866E-04	2.9488E-04	-1.6309E-05	5.4970E-05	-5.9731E-07
A14 =	-1.3625E-04	-2.6974E-04	-2.1129E-04	8.5804E-06	-3.3301E-06	—
Surface #	8	9	10	11	12	13
k =	-2.5583E+00	-2.9292E+00	-3.4410E+00	-6.6678E+00	-1.0000E+00	-5.9588E+00
A4 =	-2.0012E-02	9.5482E-03	2.1019E-02	-1.5556E-02	-5.2359E-02	-2.1721E-02
A6 =	-1.7833E-03	1.4330E-03	2.4650E-04	2.5031E-03	1.6554E-03	2.9792E-03
A8 =	-8.8439E-04	1.3061E-04	-1.0269E-03	-9.6985E-04	8.3551E-04	-2.7013E-04
A10 =	4.9856E-04	-4.7334E-06	8.6507E-05	1.7164E-04	-4.4167E-05	1.4044E-05
A12 =	-5.6334E-05	-8.1344E-06	1.7154E-05	-6.4986E-07	-4.8897E-06	-4.4447E-07
A14 =	-5.2508E-07	—	-2.5872E-06	-7.9289E-07	3.8641E-07	5.2524E-09

45

In the 4th embodiment, the equation of the aspheric surface profiles of the aforementioned lens elements is the same as the equation of the 1st embodiment. Also, the definitions of these parameters shown in the following table are the same as those stated in the 1st embodiment with corresponding values for the 4th embodiment, so an explanation in this regard will not be provided again.

Moreover, these parameters can be calculated from Table 7 and Table 8 as the following values and satisfy the following conditions:

4th Embodiment			
f [mm]	5.77	f/R8	3.55
Fno	2.30	R12/f	0.26
HFOV [deg.]	34.8	(R3-R4)/(R3 + R4)	0.55
V4	55.9	(R9-R10)/(R9 + R10)	-0.07
T12/CT2	1.28	(R10 + R12)/ImgH	0.75
T12/T23	1.36	f/f4	1.77
T12/T34	1.50	Yc62/f	0.40
T45/T34	0.65	TL/ImgH	1.88

55

60

65

5th Embodiment

FIG. 9 is a schematic view of an image capturing unit according to the 5th embodiment of the present disclosure. FIG. 10 shows, in order from left to right, spherical aberration curves, astigmatic field curves and a distortion curve of the image capturing unit according to the 5th embodiment. In FIG. 9, the image capturing unit includes the photographing optical lens assembly (its reference numeral is omitted) of the present disclosure and an image sensor 590. The photographing optical lens assembly includes, in order from an object side to an image side, a first lens element 510, an aperture stop 500, a second lens element 520, a third lens element 530, a fourth lens element 540, a fifth lens element 550, a sixth lens element 560, an IR-cut filter 570 and an image plane 580, wherein the photographing optical lens assembly has a total of six lens elements (510-560) with refractive power.

The first lens element 510 with positive refractive power has an object-side surface 511 being convex in a paraxial region thereof and an image-side surface 512 being concave in a paraxial region thereof. The first lens element 510 is made

21

of plastic material and has the object-side surface 511 and the image-side surface 512 being both aspheric.

The second lens element 520 with negative refractive power has an object-side surface 521 being convex in a paraxial region thereof and an image-side surface 522 being concave in a paraxial region thereof. The second lens element 520 is made of plastic material and has the object-side surface 521 and the image-side surface 522 being both aspheric.

The third lens element 530 with positive refractive power has an object-side surface 531 being concave in a paraxial region thereof and an image-side surface 532 being convex in a paraxial region thereof. The third lens element 530 is made of plastic material and has the object-side surface 531 and the image-side surface 532 being both aspheric.

The fourth lens element 540 with negative refractive power has an object-side surface 541 being concave in a paraxial region thereof and an image-side surface 542 being convex in a paraxial region thereof. The fourth lens element 540 is made of plastic material and has the object-side surface 541 and the image-side surface 542 being both aspheric.

The fifth lens element 550 with positive refractive power has an object-side surface 551 being convex in a paraxial

22

region thereof and an image-side surface 552 being convex in a paraxial region thereof. The fifth lens element 550 is made of plastic material and has the object-side surface 551 and the image-side surface 552 being both aspheric.

The sixth lens element 560 with negative refractive power has an object-side surface 561 being concave in a paraxial region thereof and an image-side surface 562 being concave in a paraxial region thereof. The image-side surface 562 of the sixth lens element 560 has at least one inflection point. The sixth lens element 560 is made of plastic material and has the object-side surface 561 and the image-side surface 562 being both aspheric.

The IR-cut filter 570 is made of glass and located between the sixth lens element 560 and the image plane 580, and will not affect the focal length of the photographing optical lens assembly. The image sensor 590 is disposed on or near the image plane 580 of the photographing optical lens assembly.

The detailed optical data of the 5th embodiment are shown in Table 9 and the aspheric surface data are shown in Table 10 below.

TABLE 9

5th Embodiment							
f = 5.47 mm, Fno = 2.40, HFOV = 36.0 deg.							
Surface #		Curvature Radius	Thickness	Material	Index	Abbe #	Focal Length
0	Object	Plano	Infinity				
1	Lens 1	2.577 (ASP)	0.662	Plastic	1.544	55.9	6.14
2		10.277 (ASP)	0.115				
3	Ape. Stop	Plano	0.429				
4	Lens 2	5.533 (ASP)	0.300	Plastic	1.650	21.4	-10.67
5		3.011 (ASP)	0.420				
6	Lens 3	-32.051 (ASP)	1.023	Plastic	1.544	55.9	16.62
7		-7.133 (ASP)	0.442				
8	Lens 4	-5.116 (ASP)	0.300	Plastic	1.544	55.9	-113.93
9		-5.692 (ASP)	0.053				
10	Lens 5	11.928 (ASP)	1.285	Plastic	1.544	55.9	2.95
11		-1.784 (ASP)	0.416				
12	Lens 6	-11.431 (ASP)	0.450	Plastic	1.535	55.7	-2.43
13		1.485 (ASP)	0.700				
14	IR-cut filter	Plano	0.370	Glass	1.517	64.2	—
15		Plano	0.543				
16	Image	Plano	—				

Note: Reference wavelength is 587.6 nm (d-line).

TABLE 10

Aspheric Coefficients						
Surface #	1	2	4	5	6	7
k =	1.4135E+00	-1.0000E+00	-2.2991E+00	-4.9808E+00	3.0000E+00	2.9751E+00
A4 =	-9.6940E-04	8.4522E-03	-4.8792E-02	-1.8128E-02	-1.3105E-02	-2.4973E-02
A6 =	5.3512E-04	1.5008E-03	-1.9238E-03	-2.3896E-03	-5.3979E-04	-4.4316E-03
A8 =	4.0954E-04	1.9909E-03	-4.2968E-03	9.6417E-04	-1.7333E-04	-6.7514E-05
A10 =	-2.8029E-04	-6.7625E-04	8.2036E-04	-6.6859E-04	-6.2323E-04	-4.6883E-05
A12 =	8.5124E-05	-5.6166E-04	6.2275E-05	-8.1471E-05	4.0376E-05	-7.5032E-06
A14 =	4.8763E-05	4.6338E-04	-6.4731E-04	4.8787E-05	3.2766E-06	—
Surface #	8	9	10	11	12	13
k =	4.5611E+00	2.1663E+00	-2.0000E+01	-6.1133E+00	-1.0000E+00	-5.9948E+00
A4 =	9.7054E-03	2.3573E-03	-5.9323E-03	-2.8753E-03	-2.9779E-02	-2.3111E-02
A6 =	5.4908E-04	2.7852E-03	3.9806E-04	1.5337E-03	5.4311E-04	3.2477E-03
A8 =	-8.6960E-04	2.5116E-04	-4.9017E-04	-1.0319E-03	6.5969E-04	-3.1469E-04
A10 =	4.6688E-04	-2.1363E-06	6.4372E-05	1.8150E-04	-3.5757E-05	-1.4292E-05
A12 =	-5.9519E-05	-8.0634E-06	9.3697E-06	-2.6402E-06	-3.5630E-06	-1.2185E-07
A14 =	2.3709E-06	—	-1.5531E-06	-9.4239E-07	2.4855E-07	-8.0503E-09

In the 5th embodiment, the equation of the aspheric surface profiles of the aforementioned lens elements is the same as the equation of the 1st embodiment. Also, the definitions of these parameters shown in the following table are the same as those stated in the 1st embodiment with corresponding values for the 5th embodiment, so an explanation in this regard will not be provided again.

Moreover, these parameters can be calculated from Table 9 and Table 10 as the following values and satisfy the following conditions:

5th Embodiment			
f [mm]	5.47	f/R8	0.96
Fno	2.40	R12/f	0.27
HFOV [deg.]	36.0	(R3-R4)/(R3 + R4)	0.30
V4	55.9	(R9-R10)/(R9 + R10)	1.35
T12/CT2	1.81	(R10 + R12)/ImgH	0.82
T12/T23	1.30	f/f4	-0.05
T12/T34	1.23	Yc62/f	0.39
T45/T34	0.12	TL/ImgH	1.88

6th Embodiment

FIG. 11 is a schematic view of an image capturing unit according to the 6th embodiment of the present disclosure. FIG. 12 shows, in order from left to right, spherical aberration curves, astigmatic field curves and a distortion curve of the image capturing unit according to the 6th embodiment. In FIG. 11, the image capturing unit includes the photographing optical lens assembly (its reference numeral is omitted) of the present disclosure and an image sensor 690. The photographing optical lens assembly includes, in order from an object side to an image side, a first lens element 610, an aperture stop 600, a second lens element 620, a third lens element 630, a fourth lens element 640, a fifth lens element 650, a sixth lens element 660, an IR-cut filter 670 and an image plane 680, wherein the photographing optical lens assembly has a total of six lens elements (610-660) with refractive power.

The first lens element 610 with positive refractive power has an object-side surface 611 being convex in a paraxial region thereof and an image-side surface 612 being concave in a paraxial region thereof. The first lens element 610 is made of plastic material and has the object-side surface 611 and the image-side surface 612 being both aspheric.

The second lens element 620 with negative refractive power has an object-side surface 621 being convex in a paraxial region thereof and an image-side surface 622 being concave in a paraxial region thereof. The second lens element 620 is made of plastic material and has the object-side surface 621 and the image-side surface 622 being both aspheric.

The third lens element 630 with positive refractive power has an object-side surface 631 being convex in a paraxial region thereof and an image-side surface 632 being convex in a paraxial region thereof. The object-side surface 631 of the third lens element 630 has at least one concave shape in an off-axis region thereof. The third lens element 630 is made of plastic material and has the object-side surface 631 and the image-side surface 632 being both aspheric.

The fourth lens element 640 with negative refractive power has an object-side surface 641 being concave in a paraxial region thereof and an image-side surface 642 being convex in a paraxial region thereof. The fourth lens element 640 is made of plastic material and has the object-side surface 641 and the image-side surface 642 being both aspheric.

The fifth lens element 650 with positive refractive power has an object-side surface 651 being concave in a paraxial region thereof and an image-side surface 652 being convex in a paraxial region thereof. The fifth lens element 650 is made of plastic material and has the object-side surface 651 and the image-side surface 652 being both aspheric.

The sixth lens element 660 with negative refractive power has an object-side surface 661 being convex in a paraxial region thereof and an image-side surface 662 being concave in a paraxial region thereof. The object-side surface 661 of the sixth lens element 660 has at least one concave shape in an off-axis region thereof. The image-side surface 662 of the sixth lens element 660 has at least one inflection point. The sixth lens element 660 is made of plastic material and has the object-side surface 661 and the image-side surface 662 being both aspheric.

The IR-cut filter 670 is made of glass and located between the sixth lens element 660 and the image plane 680, and will not affect the focal length of the photographing optical lens assembly. The image sensor 690 is disposed on or near the image plane 680 of the photographing optical lens assembly.

The detailed optical data of the 6th embodiment are shown in Table 11 and the aspheric surface data are shown in Table 12 below.

TABLE 11

6th Embodiment							
f = 4.80 mm, Fno = 2.40, HFOV = 38.9 deg.							
Surface #		Curvature Radius	Thickness	Material	Index	Abbe #	Focal Length
0	Object	Plano	Infinity				
1	Lens 1	2.674 (ASP)	0.591	Plastic	1.535	55.7	6.07
2		14.020 (ASP)	0.080				
3	Ape. Stop	Plano	0.329				
4	Lens 2	4.375 (ASP)	0.328	Plastic	1.634	23.8	-9.06
5		2.411 (ASP)	0.372				
6	Lens 3	10.687 (ASP)	0.788	Plastic	1.544	55.9	7.35
7		-6.229 (ASP)	0.372				
8	Lens 4	-4.569 (ASP)	0.320	Plastic	1.634	23.8	-14.14
9		-9.573 (ASP)	0.256				
10	Lens 5	-33.901 (ASP)	0.944	Plastic	1.535	55.7	2.26
11		-1.178 (ASP)	0.265				
12	Lens 6	15.372 (ASP)	0.450	Plastic	1.535	55.7	-2.07
13		1.022 (ASP)	0.850				
14	IR-cut filter	Plano	0.370	Glass	1.517	64.2	—

TABLE 11-continued

6th Embodiment						
f = 4.80 mm, Fno = 2.40, HFOV = 38.9 deg.						
Surface #		Curvature Radius	Thickness	Material	Index	Abbe # Focal Length
15		Plano	0.389			
16	Image	Plano	—			

Note: Reference wavelength is 587.6 nm (d-line).

TABLE 12

Aspheric Coefficients							
Surface #	1	2	4	5	6	7	
k =	1.2784E+00	-1.0000E+00	-1.7065E+01	-6.4485E+00	6.4885E-01	-3.2553E-02	
A4 =	-2.5777E-03	-5.8364E-04	-4.7516E-02	-1.4126E-02	-1.0317E-02	-1.8045E-02	
A6 =	8.6083E-04	5.0355E-03	9.1374E-03	3.0979E-03	-2.7564E-04	-1.6399E-03	
A8 =	3.2637E-05	3.8807E-04	-4.7377E-03	7.2777E-04	-2.7455E-04	-1.7291E-03	
A10 =	1.6925E-04	-1.0539E-03	1.6105E-04	-1.2471E-03	-4.8270E-04	4.0073E-04	
A12 =	-4.9160E-05	-2.8395E-04	-4.2104E-04	1.3519E-04	4.2549E-05	-5.3762E-05	
A14 =	5.6877E-05	5.5212E-04	2.9261E-05	4.6026E-05	2.0739E-05	—	
Surface #	8	9	10	11	12	13	
k =	3.4416E+00	1.0458E+01	-2.0000E+01	-4.5285E+00	-1.0000E+00	-4.9486E+00	
A4 =	-1.1775E-02	-2.2692E-02	-1.2217E-02	-2.0245E-02	-3.7173E-02	-2.3565E-02	
A6 =	2.0135E-03	2.4939E-03	9.4706E-04	7.3349E-03	7.6159E-04	3.3508E-03	
A8 =	4.0579E-04	3.3609E-04	-2.6752E-04	-1.3811E-03	6.7092E-04	-3.4363E-04	
A10 =	6.3492E-04	6.5754E-05	-9.6236E-05	2.0155E-04	-3.7364E-05	1.5671E-05	
A12 =	-6.0716E-05	8.2448E-06	2.0539E-05	-1.5946E-06	-3.6085E-06	-3.5459E-07	
A14 =	-1.1102E-05	—	-3.6476E-06	-2.2397E-06	2.6455E-07	8.3415E-09	

In the 6th embodiment, the equation of the aspheric surface profiles of the aforementioned lens elements is the same as the equation of the 1st embodiment. Also, the definitions of these parameters shown in the following table are the same as those stated in the 1st embodiment with corresponding values for the 6th embodiment, so an explanation in this regard will not be provided again.

Moreover, these parameters can be calculated from Table 11 and Table 12 as the following values and satisfy the following conditions:

6th Embodiment			
f [mm]	4.80	f/R8	0.50
Fno	2.40	R12/f	0.21
HFOV [deg.]	38.9	(R3-R4)/(R3 + R4)	0.29
V4	23.8	(R9-R10)/(R9 + R10)	0.93
T12/CT2	1.25	(R10 + R12)/ mgH	0.55
T12/T23	1.10	f/f4	-0.34
T12/T34	1.10	Yc62/f	0.46
T45/T34	0.69	TL/ mgH	1.68

7th Embodiment

FIG. 13 is a schematic view of an image capturing unit according to the 7th embodiment of the present disclosure. FIG. 14 shows, in order from left to right, spherical aberration curves, astigmatic field curves and a distortion curve of the image capturing unit according to the 7th embodiment. In FIG. 13, the image capturing unit includes the photographing optical lens assembly (its reference numeral is omitted) of the present disclosure and an image sensor 790. The photograph-

ing optical lens assembly includes, in order from an object side to an image side, an aperture stop 700, a first lens element 710, a second lens element 720, a third lens element 730, a fourth lens element 740, a fifth lens element 750, a sixth lens element 760, an IR-cut filter 770 and an image plane 780, wherein the photographing optical lens assembly has a total of six lens elements (710-760) with refractive power.

The first lens element 710 with positive refractive power has an object-side surface 711 being convex in a paraxial region thereof and an image-side surface 712 being concave in a paraxial region thereof. The first lens element 710 is made of glass material and has the object-side surface 711 and the image-side surface 712 being both aspheric.

The second lens element 720 with negative refractive power has an object-side surface 721 being concave in a paraxial region thereof and an image-side surface 722 being concave in a paraxial region thereof. The second lens element 720 is made of plastic material and has the object-side surface 721 and the image-side surface 722 being both aspheric.

The third lens element 730 with positive refractive power has an object-side surface 731 being convex in a paraxial region thereof and an image-side surface 732 being concave in a paraxial region thereof. The object-side 731 surface of the third lens element 730 has at least one concave shape in an off-axis region thereof. The third lens element 730 is made of plastic material and has the object-side surface 731 and the image-side surface 732 being both aspheric.

The fourth lens element 740 with positive refractive power has an object-side surface 741 being convex in a paraxial region thereof and an image-side surface 742 being convex in a paraxial region thereof. The fourth lens element 740 is made

of plastic material and has the object-side surface 741 and the image-side surface 742 being both aspheric.

The fifth lens element 750 with positive refractive power has an object-side surface 751 being concave in a paraxial region thereof and an image-side surface 752 being convex in a paraxial region thereof. The fifth lens element 750 is made of plastic material and has the object-side surface 751 and the image-side surface 752 being both aspheric.

The sixth lens element 760 with negative refractive power has an object-side surface 761 being convex in a paraxial region thereof and an image-side surface 762 being concave in a paraxial region thereof. The object-side surface 761 of the sixth lens element 760 has at least one concave shape in an

off-axis region thereof. The image-side surface 762 of the sixth lens element 760 has at least one inflection point. The sixth lens element 760 is made of plastic material and has the object-side surface 761 and the image-side surface 762 being both aspheric.

The IR-cut filter 770 is made of glass and located between the sixth lens element 760 and the image plane 780, and will not affect the focal length of the photographing optical lens assembly. The image sensor 790 is disposed on or near the image plane 780 of the photographing optical lens assembly.

The detailed optical data of the 7th embodiment are shown in Table 13 and the aspheric surface data are shown in Table 14 below.

TABLE 13

7th Embodiment								
f = 4.84 mm, Fno = 2.00, HFOV = 41.7 deg.								
Surface #		Curvature Radius	Thickness	Material	Index	Abbe #	Focal Length	
0	Object	Plano	Infinity					
1	Ape. Stop	Plano	-0.280					
2	Lens 1	2.741 (ASP)	0.618	Glass	1.547	53.6	7.33	
3		7.970 (ASP)	0.619					
4	Lens 2	-31.686 (ASP)	0.431	Plastic	1.632	23.4	-6.74	
5		4.949 (ASP)	0.104					
6	Lens 3	4.974 (ASP)	0.909	Plastic	1.535	56.3	13.59	
7		14.759 (ASP)	0.271					
8	Lens 4	10.936 (ASP)	0.901	Plastic	1.544	55.9	2.33	
9		-1.395 (ASP)	0.215					
10	Lens 5	-1.268 (ASP)	0.770	Plastic	1.535	56.3	6.08	
11		-1.105 (ASP)	0.121					
12	Lens 6	9.406 (ASP)	0.450	Plastic	1.544	55.9	-2.07	
13		0.988 (ASP)	0.800					
14	IR-cut filter	Plano	0.370	Glass	1.517	64.2	—	
15		Plano	0.659					
16	Image	Plano	—					

Note: Reference wavelength is 587.6 nm (d-line).

TABLE 14

Aspheric Coefficients						
Surface #	2	3	4	5	6	7
k =	1.1894E+00	-1.0000E+00	-2.8241E+00	-1.8557E+01	-2.0000E+01	-2.0000E+01
A4 =	-4.1830E-03	-4.3502E-03	-5.3486E-02	-1.9885E-02	5.9208E-03	-2.0869E-02
A6 =	1.1674E-03	-1.1656E-03	-9.9723E-04	-1.1456E-03	-1.8172E-03	-1.4477E-03
A8 =	-2.6291E-03	-2.6377E-03	-4.5181E-03	1.6439E-03	5.9219E-04	-4.4271E-05
A10 =	2.3174E-05	-1.1748E-03	1.1027E-03	-3.9212E-04	-3.4130E-04	-7.0326E-05
A12 =	9.6426E-04	1.1787E-03	1.6486E-04	-1.3484E-04	5.7740E-05	1.1669E-05
A14 =	-6.3898E-04	-8.7615E-04	-9.1477E-04	4.8149E-05	-3.1551E-06	—
Surface #	8	9	10	11	12	13
k =	3.0000E+00	-3.2142E+00	-3.5823E+00	-4.9767E+00	-1.0000E+00	-4.6903E+00
A4 =	-1.0764E-02	8.7832E-03	2.5685E-02	-1.5327E-02	-5.9943E-02	-2.6396E-02
A6 =	-5.6690E-04	2.2083E-03	7.1069E-04	3.8435E-03	8.5393E-04	3.6658E-03
A8 =	-1.0202E-03	1.5323E-04	-9.5757E-04	-1.1227E-03	8.5283E-04	-3.3633E-04
A10 =	4.7387E-04	-2.0517E-05	4.4542E-05	1.5192E-04	-3.5958E-05	1.5060E-05
A12 =	-5.8894E-05	-1.0967E-05	1.0023E-05	-9.5230E-07	-4.3277E-06	-2.8632E-07
A14 =	9.0138E-07	—	-1.5157E-06	-4.6880E-07	3.2689E-07	8.3539E-10

29

In the 7th embodiment, the equation of the aspheric surface profiles of the aforementioned lens elements is the same as the equation of the 1st embodiment. Also, the definitions of these parameters shown in the following table are the same as those stated in the 1st embodiment with corresponding values for the 7th embodiment, so an explanation in this regard will not be provided again.

Moreover, these parameters can be calculated from Table 13 and Table 14 as the following values and satisfy the following conditions:

7th Embodiment			
f [mm]	4.84	f/R8	3.47
Fno	2.00	R12/f	0.20
HFOV [deg.]	41.7	(R3-R4)/(R3 + R4)	1.37
V4	55.9	(R9-R10)/(R9 + R10)	0.07
T12/CT2	1.44	(R10 + R12)/ImgH	0.50
T12/T23	5.95	f/f4	2.07
T12/T34	2.28	Yc62/f	0.46
T45/T34	0.79	TL/ImgH	1.74

The foregoing image capturing unit **10** is able to be installed in, but not limited to, a mobile device, including a smart phone, a tablet personal computer or a wearable device. Moreover, according to the present disclosure, since the photographing optical lens assembly has a total of six lens elements with refractive power, and the largest air gap in a paraxial region between any two of the first lens element, the second lens element, the third lens element, the fourth lens element, the fifth lens element and the sixth lens element that are adjacent to each other is between the first lens element and the second lens element. Consequently, it is favorable for assembling the lens elements by adjusting the axial distances between every lens element. In particular, it is favorable for the first lens element avoiding being in contact with the second lens element by designing the largest air gap in a paraxial region between the first lens element and the second lens element. Moreover, it is also favorable for disposing additional optical components such as actuator, shutter and filter.

The foregoing description, for purpose of explanation, has been described with reference to specific embodiments. It is to be noted that TABLES 1-14 show different data of the different embodiments; however, the data of the different embodiments are obtained from experiments. The embodiments were chosen and described in order to best explain the principles of the disclosure and its practical applications, to thereby enable others skilled in the art to best utilize the disclosure and various embodiments with various modifications as are suited to the particular use contemplated. The embodiments depicted above and the appended drawings are exemplary and are not intended to be exhaustive or to limit the scope of the present disclosure to the precise forms disclosed. Many modifications and variations are possible in view of the above teachings.

What is claimed is:

1. A photographing optical lens assembly comprising, in order from an object side to an image side:

- a first lens element having positive refractive power;
- a second lens element with negative refractive power having an object-side surface being convex in a paraxial region thereof and an image-side surface being concave in a paraxial region thereof;
- a third lens element having refractive power;
- a fourth lens element having refractive power;
- a fifth lens element having refractive power, wherein both of an object-side surface and an image-side surface of the fifth lens element are aspheric; and

30

a sixth lens element with refractive power having an image-side surface being concave in a paraxial region thereof, wherein both of an object-side surface and the image-side surface of the sixth lens element are aspheric, and the image-side surface of the sixth lens element has at least one inflection point;

wherein the photographing optical lens assembly has a total of six lens elements with refractive power, the largest air gap in a paraxial region between any two of the first through sixth lens elements that are adjacent to each other is between the first lens element and the second lens element, a focal length of the photographing optical lens assembly is f, a vertical distance between a non-axial critical point on the image-side surface of the sixth lens element and an optical axis is Yc62, a curvature radius of an image-side surface of the fourth lens element is R8, a curvature radius of the object-side surface of the fifth lens element is R9, a curvature radius of the image-side surface of the fifth lens element is R10, and the following conditions are satisfied:

$$0.20 < Yc62/f < 0.90;$$

$$0.40 < |f/R8|; \text{ and}$$

$$-0.30 < (R9-R10)/(R9+R10) < 3.00.$$

2. The photographing optical lens assembly of claim **1**, wherein the sixth lens element has negative refractive power.

3. The photographing optical lens assembly of claim **1**, wherein the image-side surface of the fifth lens element is convex in a paraxial region thereof.

4. The photographing optical lens assembly of claim **1**, wherein the curvature radius of the image-side surface of the fifth lens element is R10, a curvature radius of the image-side surface of the sixth lens element is R12, a maximum image height of the photographing optical lens assembly is ImgH, and the following condition is satisfied:

$$0 < (|R10| + |R12|)/\text{ImgH} < 1.20.$$

5. The photographing optical lens assembly of claim **1**, wherein the third lens element has an object-side surface being convex in a paraxial region thereof, and the object-side surface of the third lens element has at least one concave shape in an off-axis region thereof.

6. The photographing optical lens assembly of claim **1**, wherein an axial distance between the first lens element and the second lens element is T12, a central thickness of the second lens element is CT2, and the following condition is satisfied:

$$1.00 < T12/CT2 < 3.50.$$

7. The photographing optical lens assembly of claim **1**, wherein the fourth lens element has an object-side surface being concave in a paraxial region thereof.

8. The photographing optical lens assembly of claim **1**, wherein the first lens element has an object-side surface being convex in a paraxial region thereof, and an image-side surface being concave in a paraxial region thereof.

9. The photographing optical lens assembly of claim **1**, wherein an axial distance between the first lens element and the second lens element is T12, an axial distance between the second lens element and the third lens element is T23, and the following condition is satisfied:

$$1.00 < T12/T23 < 1.80.$$

10. The photographing optical lens assembly of claim **1**, wherein a curvature radius of the image-side surface of the

31

sixth lens element is R12, the focal length of the photographing optical lens assembly is f , and the following condition is satisfied:

$$0 < R12/f < 1.0.$$

11. The photographing optical lens assembly of claim 1, wherein the focal length of the photographing optical lens assembly is f , the curvature radius of the image-side surface of the fourth lens element is R8, and the following condition is satisfied:

$$0.90 < f/R8.$$

12. The photographing optical lens assembly of claim 1, wherein an axial distance between an object-side surface of the first lens element and an image plane is TL, a maximum image height of the photographing optical lens assembly is ImgH, and the following condition is satisfied:

$$TL/ImgH < 2.00.$$

13. An image capturing unit, comprising: the photographing optical lens assembly of claim 1; and an image sensor, wherein the image sensor is disposed on the image side of the photographing optical lens assembly.

14. A mobile device, comprising: the image capturing unit of claim 13.

15. A photographing optical lens assembly comprising, in order from an object side to an image side:

- a first lens element having positive refractive power;
- a second lens element having refractive power;
- a third lens element having refractive power;
- a fourth lens element having refractive power;
- a fifth lens element having refractive power, wherein both of an object-side surface and an image-side surface of the fifth lens element are aspheric; and
- a sixth lens element with negative refractive power having an image-side surface being concave in a paraxial region thereof, wherein both of an object-side surface and the image-side surface of the sixth lens element are aspheric, and the image-side surface of the sixth lens element has at least one inflection point;

wherein the photographing optical lens assembly has a total of six lens elements with refractive power, the largest air gap in a paraxial region between any two of the first through sixth lens elements that are adjacent to each other is between the first lens element and the second lens element, a focal length of the photographing optical lens assembly is f , a curvature radius of an image-side surface of the fourth lens element is R8, a vertical distance between a non-axial critical point on the image-side surface of the sixth lens element and an optical axis is Yc62, an Abbe number of the fourth lens element is V4, and the following conditions are satisfied:

$$0.20 < Yc62/f < 0.90;$$

$$0.40 < f/R8; \text{ and}$$

$$32.0 < V4 < 70.0.$$

16. The photographing optical lens assembly of claim 15, wherein the fourth lens element has positive refractive power.

17. The photographing optical lens assembly of claim 16, wherein the focal length of the photographing optical lens assembly is f , a focal length of the fourth lens element is $f4$, and the following condition is satisfied:

$$0.50 < f/f4 < 2.50.$$

18. The photographing optical lens assembly of claim 15, wherein the fourth lens element has an image-side surface being convex in a paraxial region thereof.

32

19. The photographing optical lens assembly of claim 15, wherein a curvature radius of the image-side surface of the sixth lens element is R12, the focal length of the photographing optical lens assembly is f , and the following condition is satisfied:

$$0 < R12/f < 1.0.$$

20. The photographing optical lens assembly of claim 15, wherein an axial distance between the first lens element and the second lens element is T12, an axial distance between the third lens element and the fourth lens element is T34, and the following condition is satisfied:

$$1.00 < T12/T34 < 2.30.$$

21. A photographing optical lens assembly comprising, in order from an object side to an image side:

- a first lens element with positive refractive power having an object-side surface being convex in a paraxial region thereof;
- a second lens element with negative refractive power having an image-side surface being concave in a paraxial region thereof;
- a third lens element having refractive power;
- a fourth lens element having refractive power;
- a fifth lens element having refractive power, wherein both of an object-side surface and an image-side surface of the fifth lens element are aspheric; and
- a sixth lens element with refractive power having an object-side surface being convex in a paraxial region and an image-side surface being concave in a paraxial region thereof, wherein both of the object-side surface and the image-side surface of the sixth lens element are aspheric, and the image-side surface of the sixth lens element has at least one inflection point;

wherein the photographing optical lens assembly has a total of six lens elements with refractive power, the largest air gap in a paraxial region between any two of the first through sixth lens elements that are adjacent to each other is between the first lens element and the second lens element, a vertical distance between a non-axial critical point on the image-side surface of the sixth lens element and an optical axis is Yc62, a focal length of the photographing optical lens assembly is f , a curvature radius of an object-side surface of the second lens element is R3, a curvature radius of the image-side surface of the second lens element is R4, a curvature radius of the object-side surface of the fifth lens element is R9, a curvature radius of the image-side surface of the fifth lens element is R10, and the following conditions are satisfied:

$$0.20 < Yc62/f < 0.90;$$

$$-0.30 < (R9-R10)/(R9+R10) < 3.00; \text{ and}$$

$$0 < (R3-R4)/(R3+R4) < 10.00.$$

22. The photographing optical lens assembly of claim 21, wherein the object-side surface of the sixth lens element is convex in a paraxial region thereof, and the object-side surface of the sixth lens element has at least one concave shape in an off-axis region thereof.

23. The photographing optical lens assembly of claim 22, wherein the fifth lens element has positive refractive power, and there is an air gap in a paraxial region between any two of the first lens element, the second lens element, the third lens element, the fourth lens element, the fifth lens element and the sixth lens element that are adjacent to each other.

24. The photographing optical lens assembly of claim 22, wherein the object-side surface of the fifth lens element is concave in a paraxial region thereof.

25. The photographing optical lens assembly of claim 23, wherein an axial distance between the third lens element and the fourth lens element is T34, an axial distance between the fourth lens element and the fifth lens element is T45, and the following condition is satisfied:

$$0 < T45/T34 < 1.50.$$

26. The photographing optical lens assembly of claim 23, wherein the curvature radius of the image-side surface of the fifth lens element is R10, a curvature radius of the image-side surface of the sixth lens element is R12, a maximum image height of the photographing optical lens assembly is ImgH, and the following condition is satisfied:

$$0 < (|R10| + |R12|)/\text{ImgH} < 1.20.$$

* * * * *