



US008743478B2

(12) **United States Patent**
Tsai et al.

(10) **Patent No.:** **US 8,743,478 B2**
(45) **Date of Patent:** **Jun. 3, 2014**

(54) **OPTICAL LENS FOR IMAGE PICKUP**

(75) Inventors: **Tsung-Han Tsai**, Taichung (TW);
Ming-Ta Chou, Taichung (TW)

(73) Assignee: **Largan Precision Co.**, Taichung (TW)

(*) Notice: Subject to any disclaimer, the term of this patent is extended or adjusted under 35 U.S.C. 154(b) by 198 days.

(21) Appl. No.: **13/399,426**

(22) Filed: **Feb. 17, 2012**

(65) **Prior Publication Data**
US 2013/0016435 A1 Jan. 17, 2013

(30) **Foreign Application Priority Data**
Jul. 11, 2011 (TW) 100124481 A

(51) **Int. Cl.**
G02B 13/18 (2006.01)
G02B 9/60 (2006.01)

(52) **U.S. Cl.**
USPC 359/714; 359/764

(58) **Field of Classification Search**
USPC 359/713-714, 763-764
See application file for complete search history.

(56) **References Cited**

U.S. PATENT DOCUMENTS

7,480,105 B2	1/2009	Mori	
7,663,813 B2	2/2010	Lai	
2010/0134904 A1*	6/2010	Tsai	359/764
2010/0220229 A1*	9/2010	Sano	348/340
2011/0134305 A1*	6/2011	Sano et al.	348/340
2011/0188131 A1*	8/2011	Sano	359/714

* cited by examiner

Primary Examiner — Jordan Schwartz

(74) *Attorney, Agent, or Firm* — Wang Law Firm, Inc.; Li K. Wang; Stephen Hsu

(57) **ABSTRACT**

An optical lens for image pickup, sequentially arranged from an object side to an image side along the optical axis comprising: a first lens element with positive refractive power having a convex object-side surface; a second lens element with negative refractive power; a third lens element with positive refractive power having biconvex surfaces with at least one aspheric surface; and a plastic fifth lens element with negative refractive power having a concave image-side surface, with at least one aspheric surface and at least one inflection point. By such arrangements, the optical lens for image pickup satisfies conditions related to shorten the total length and to reduce the sensitivity for use in compact cameras and mobile phones with camera functionalities.

22 Claims, 12 Drawing Sheets

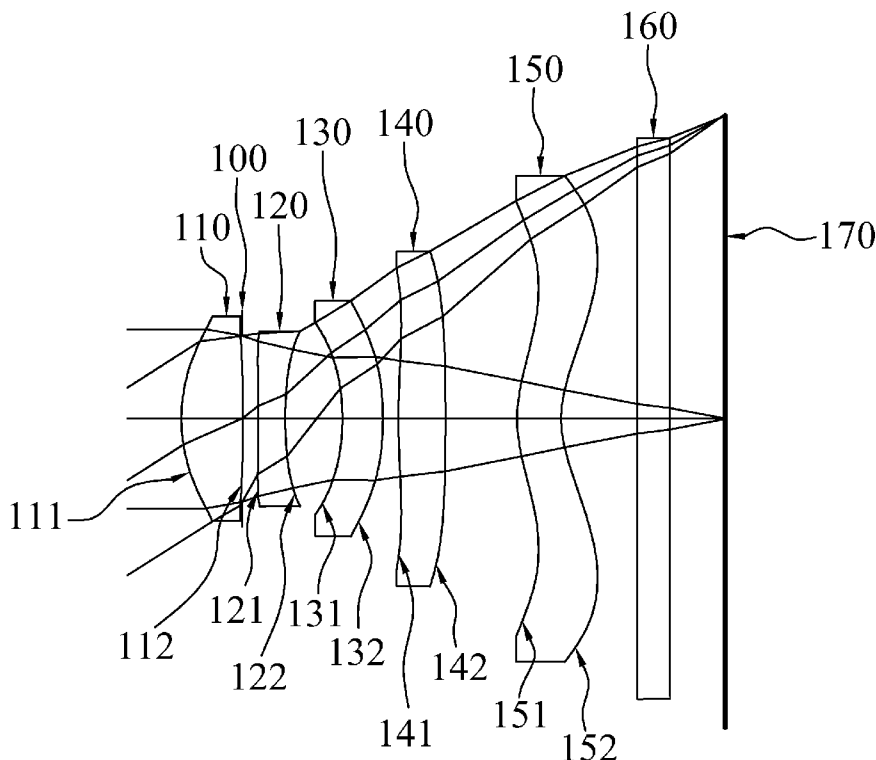

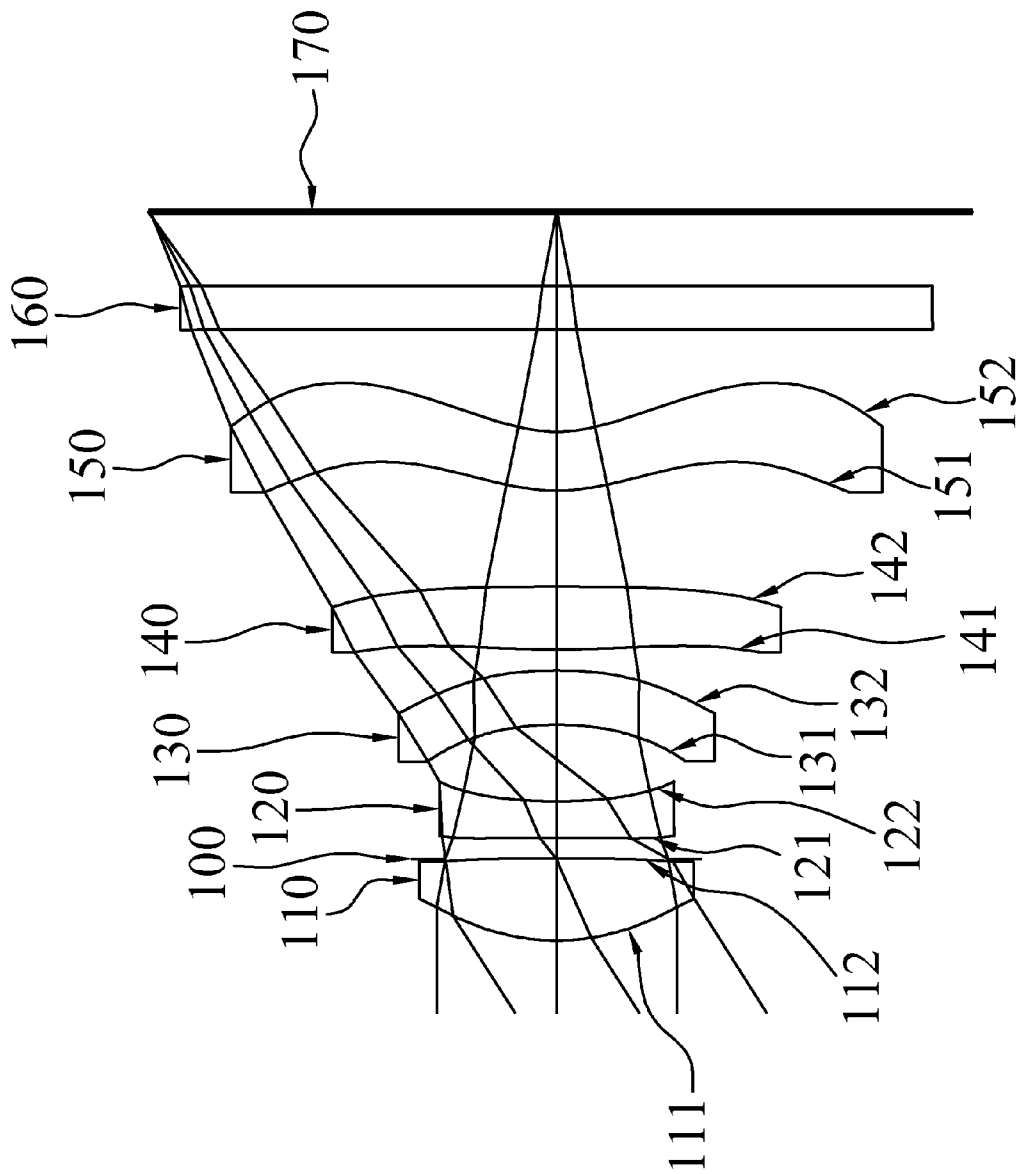

FIG. 1A

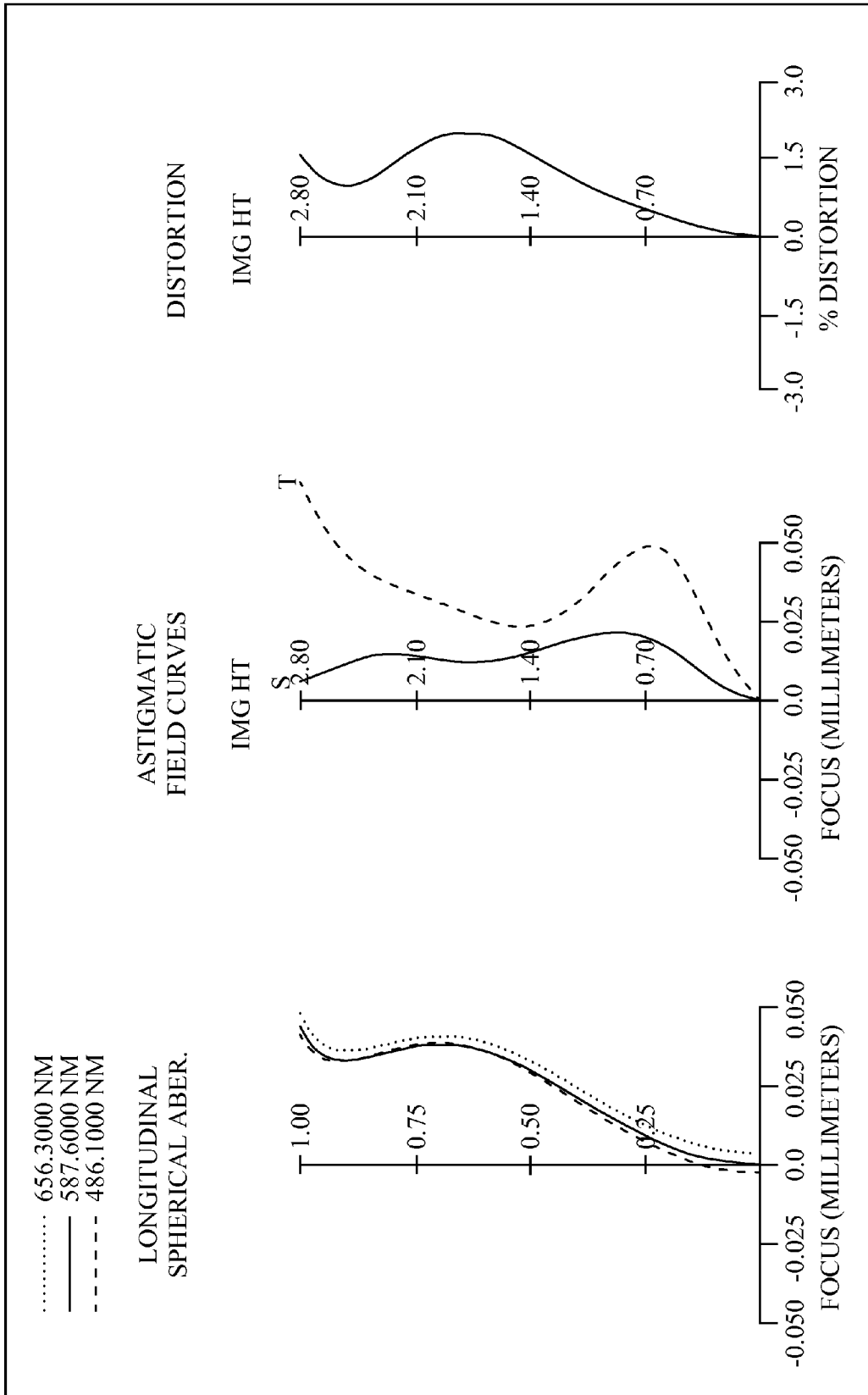

FIG. 1B

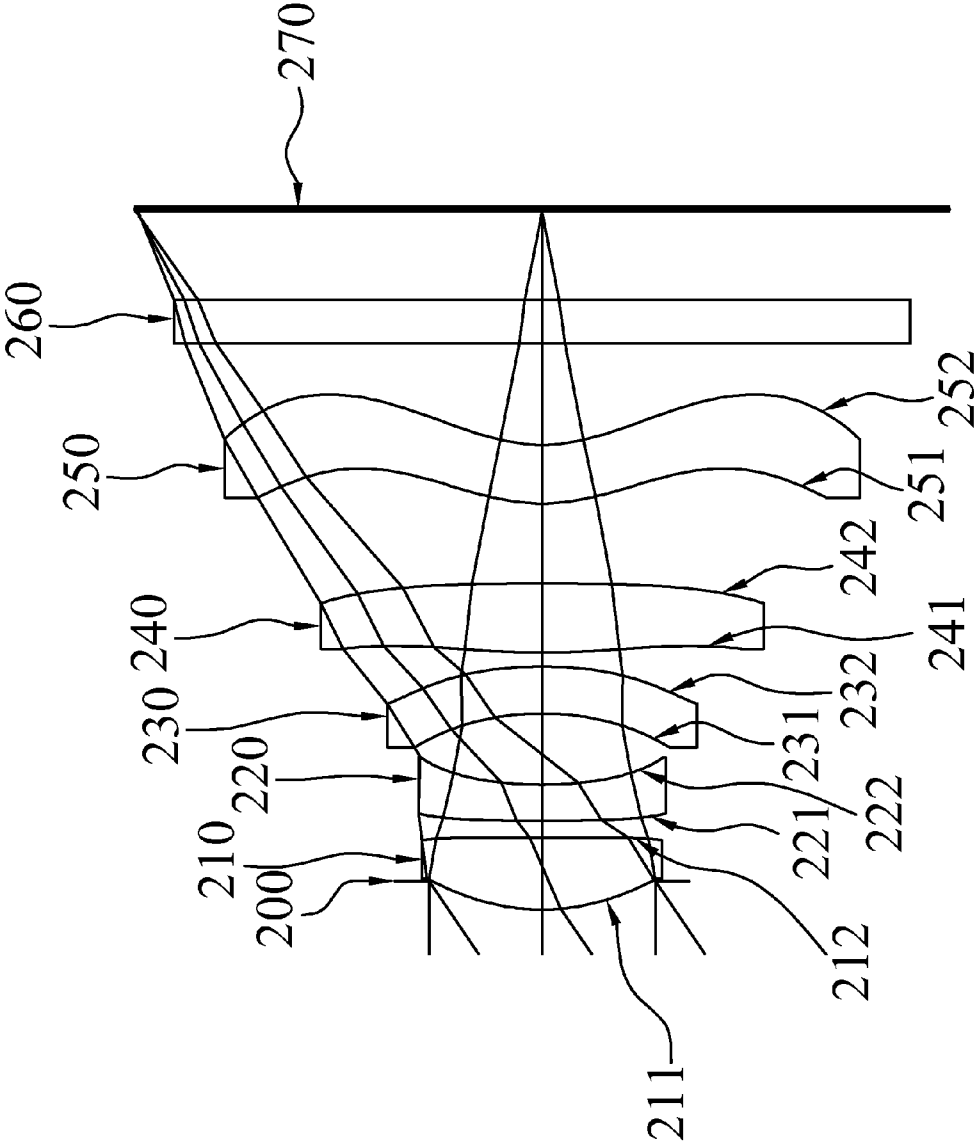

FIG. 2A

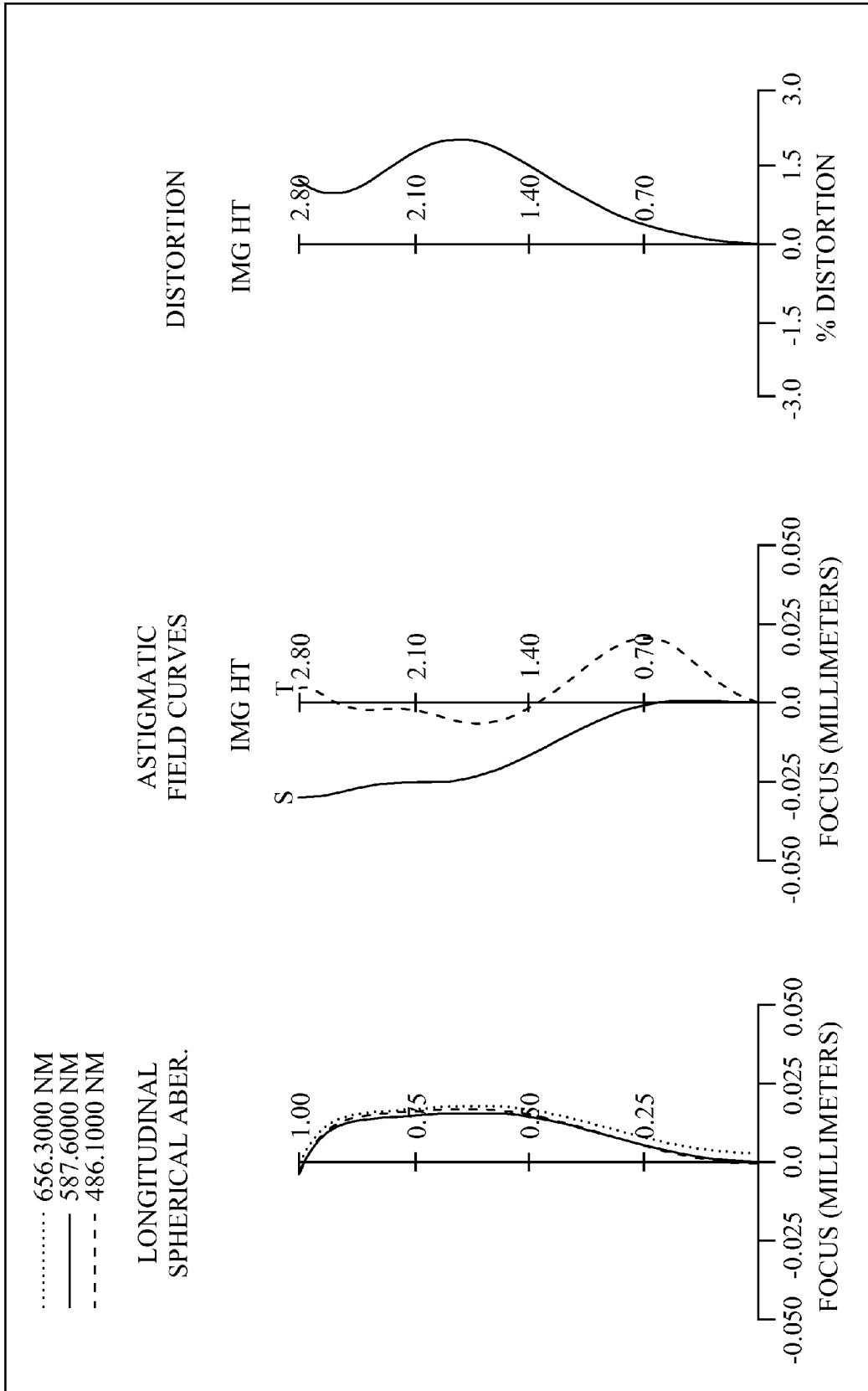

FIG. 2B

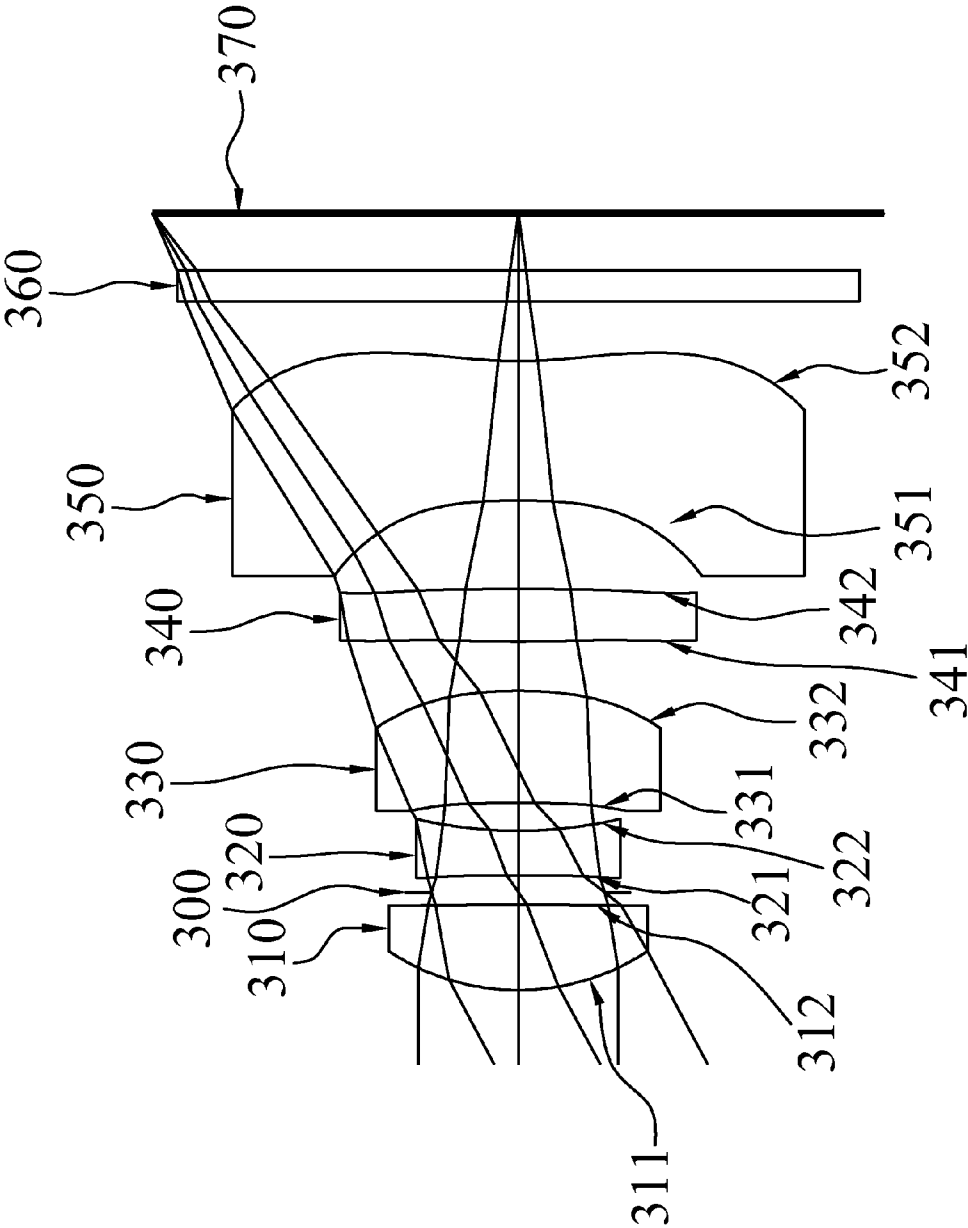

FIG. 3A

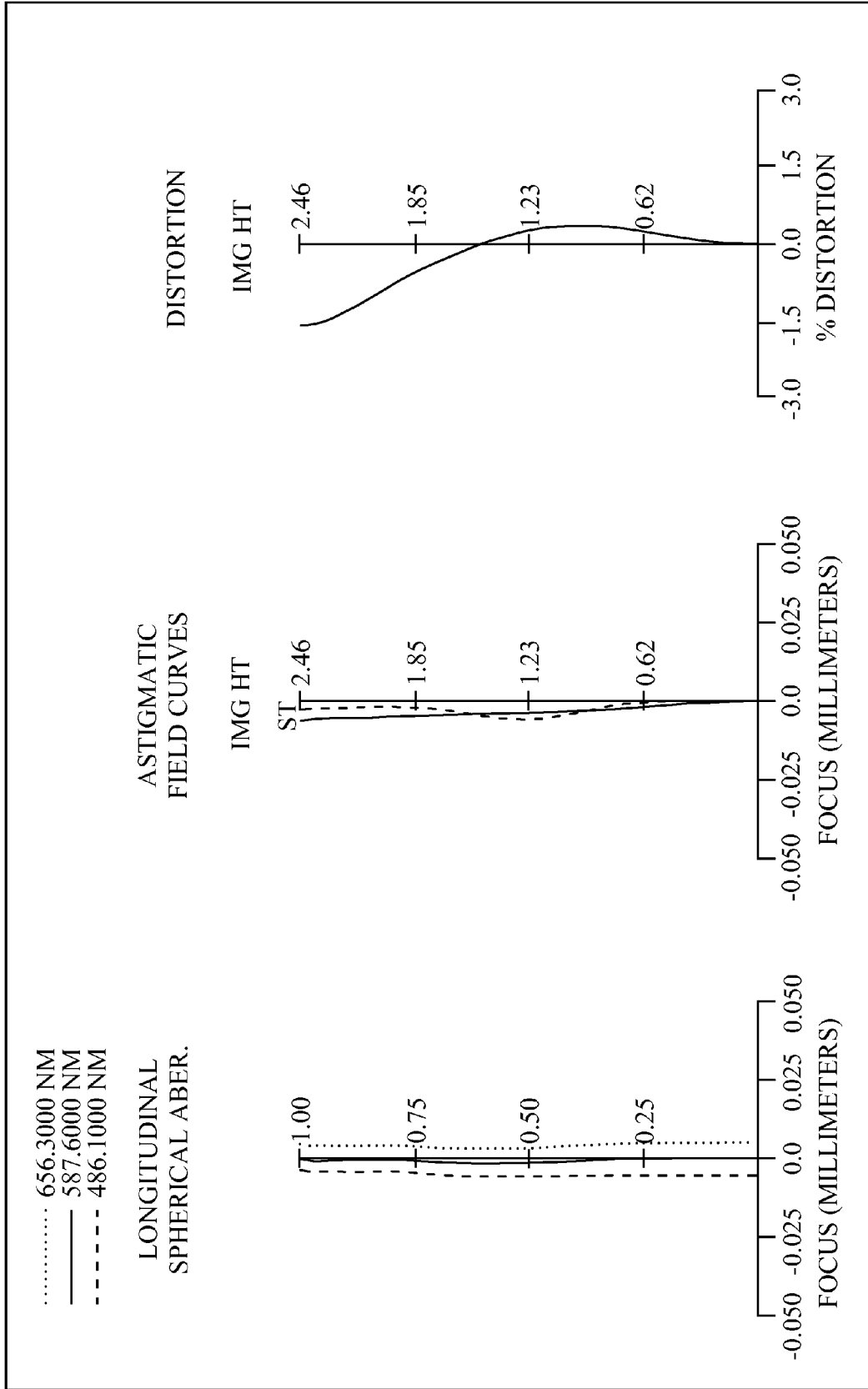

FIG. 3B

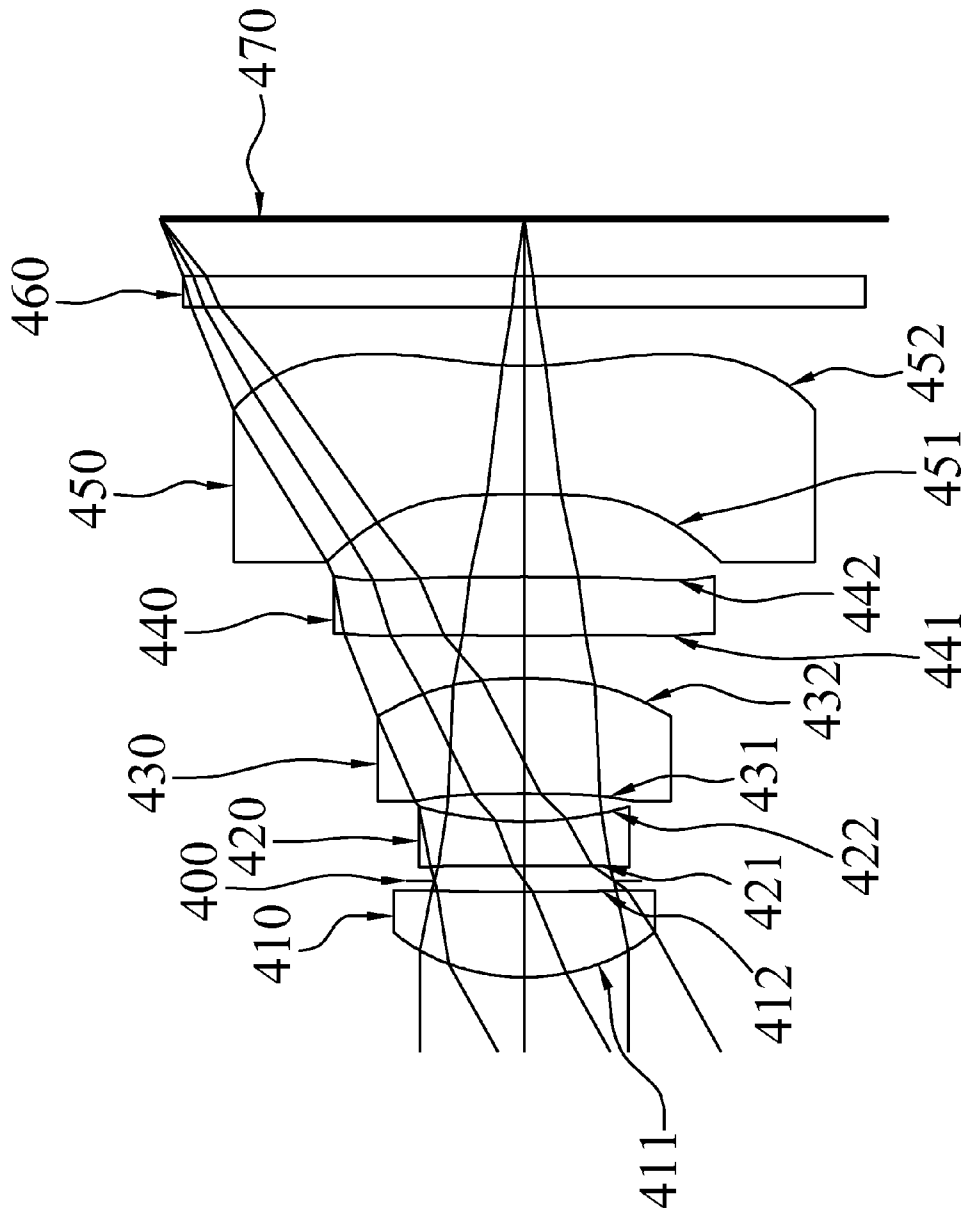

FIG. 4A

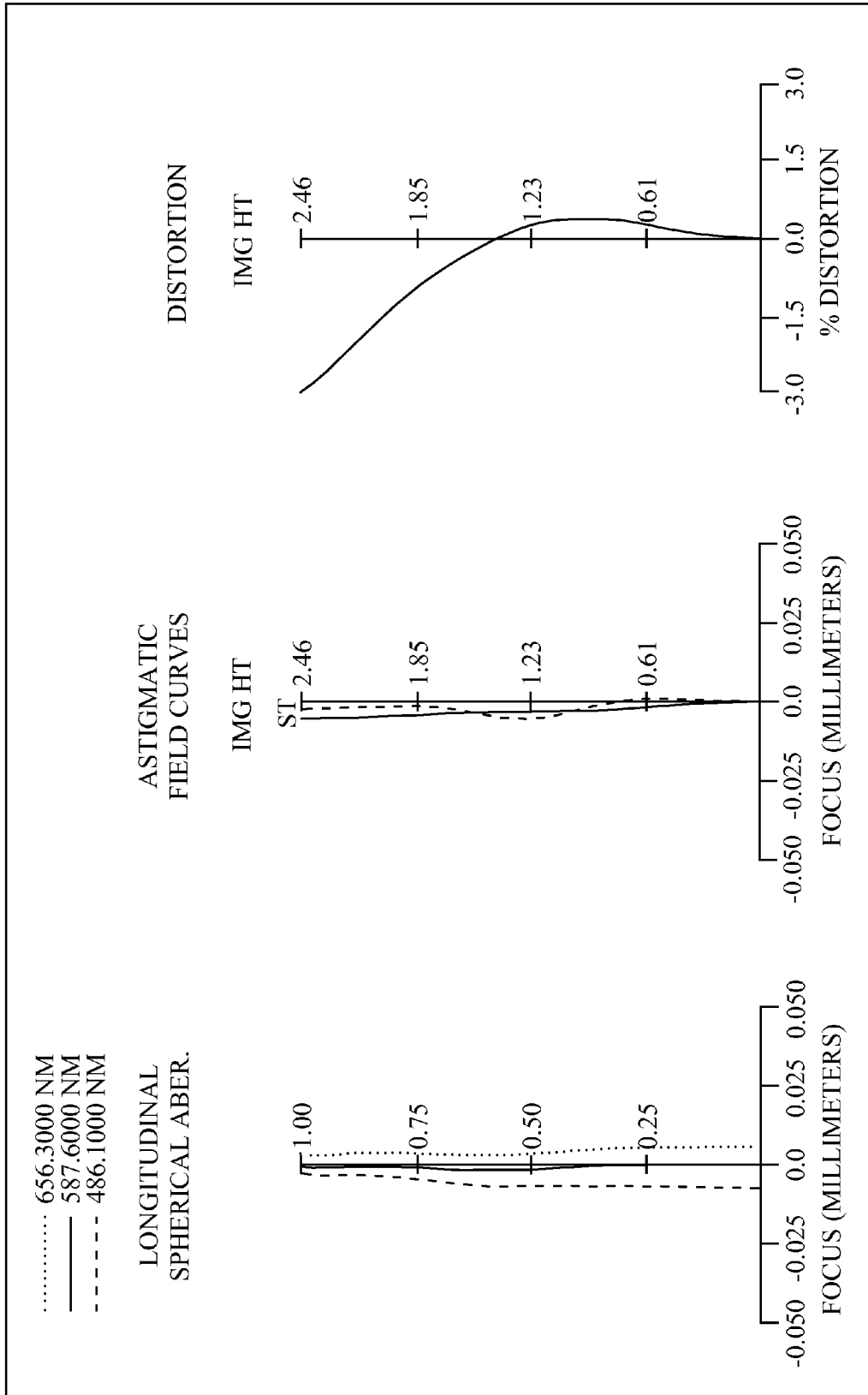

FIG. 4B

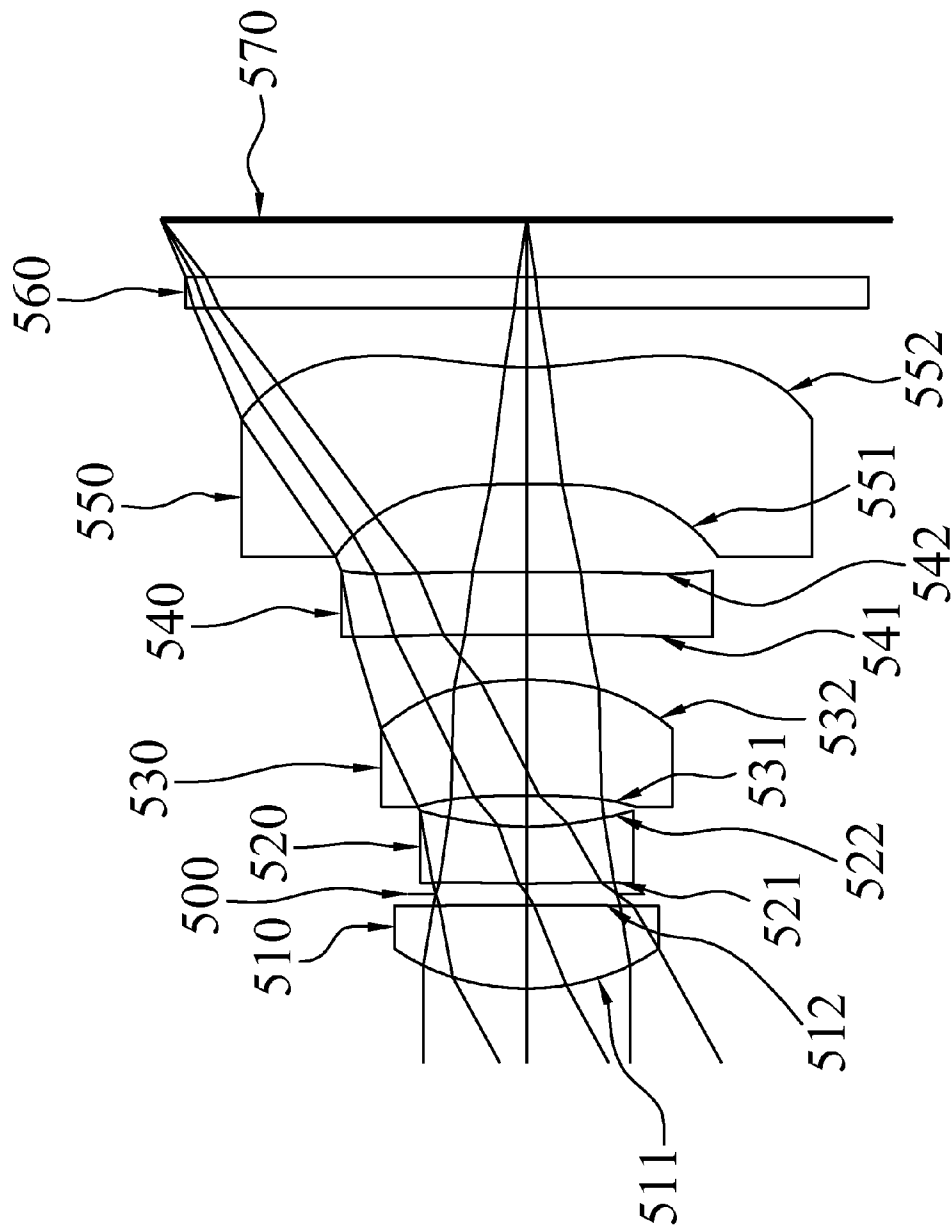

FIG. 5A

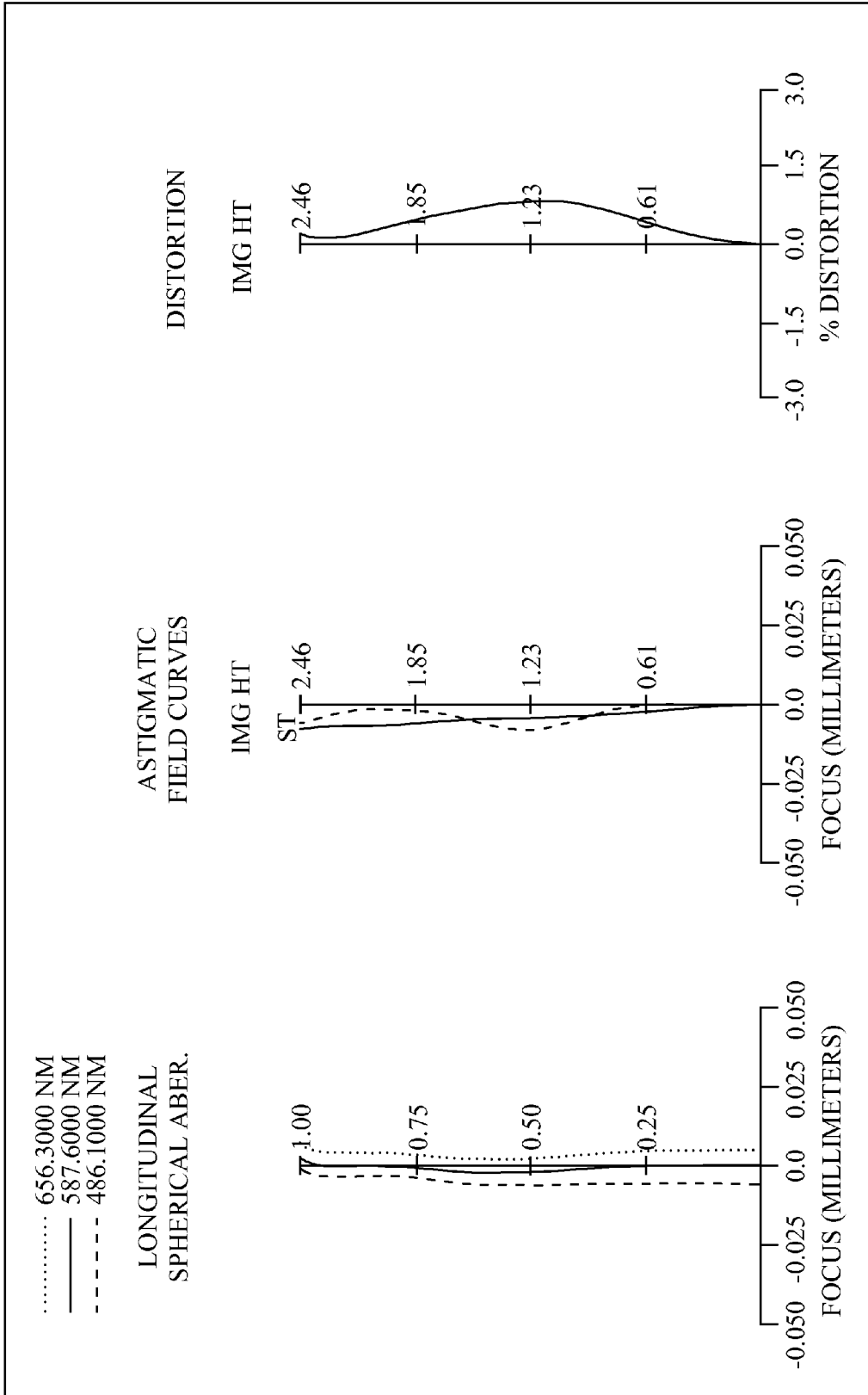

FIG. 5B

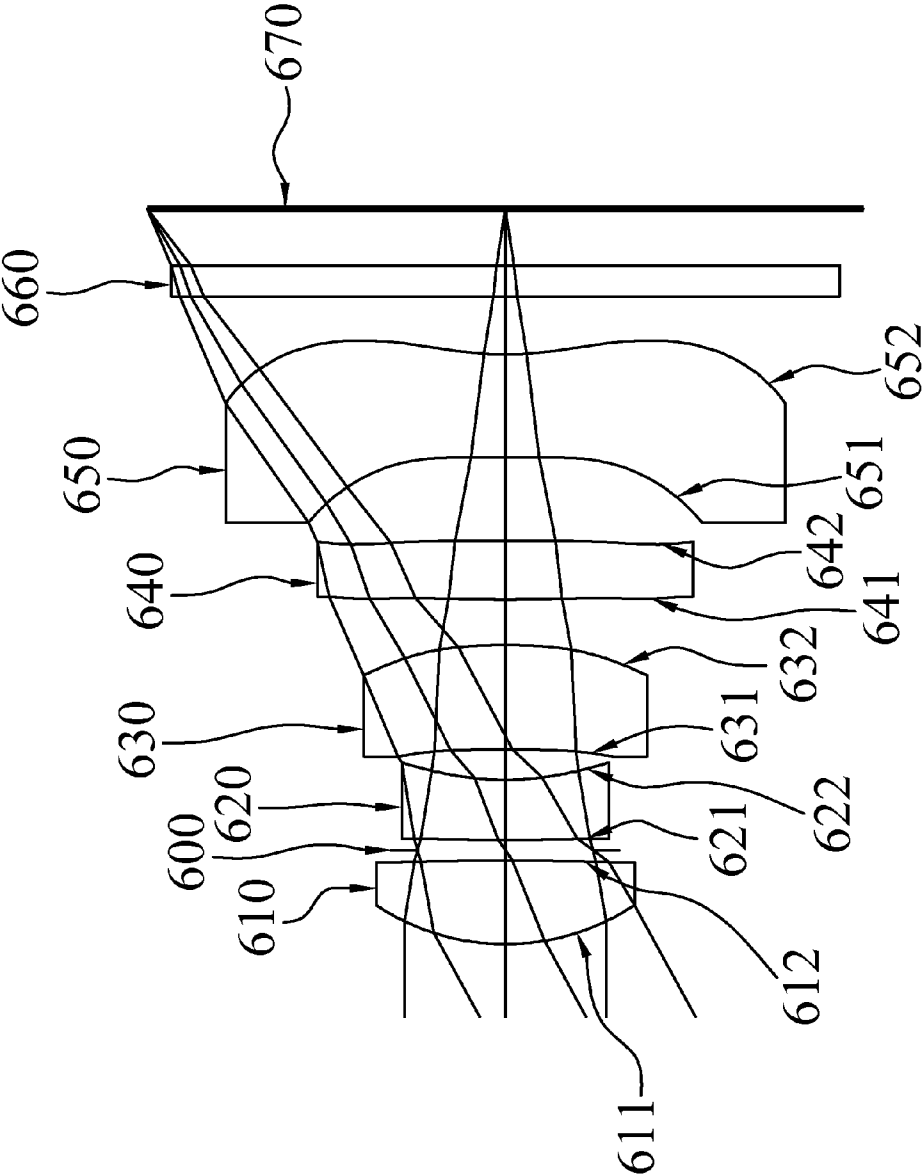

FIG. 6A

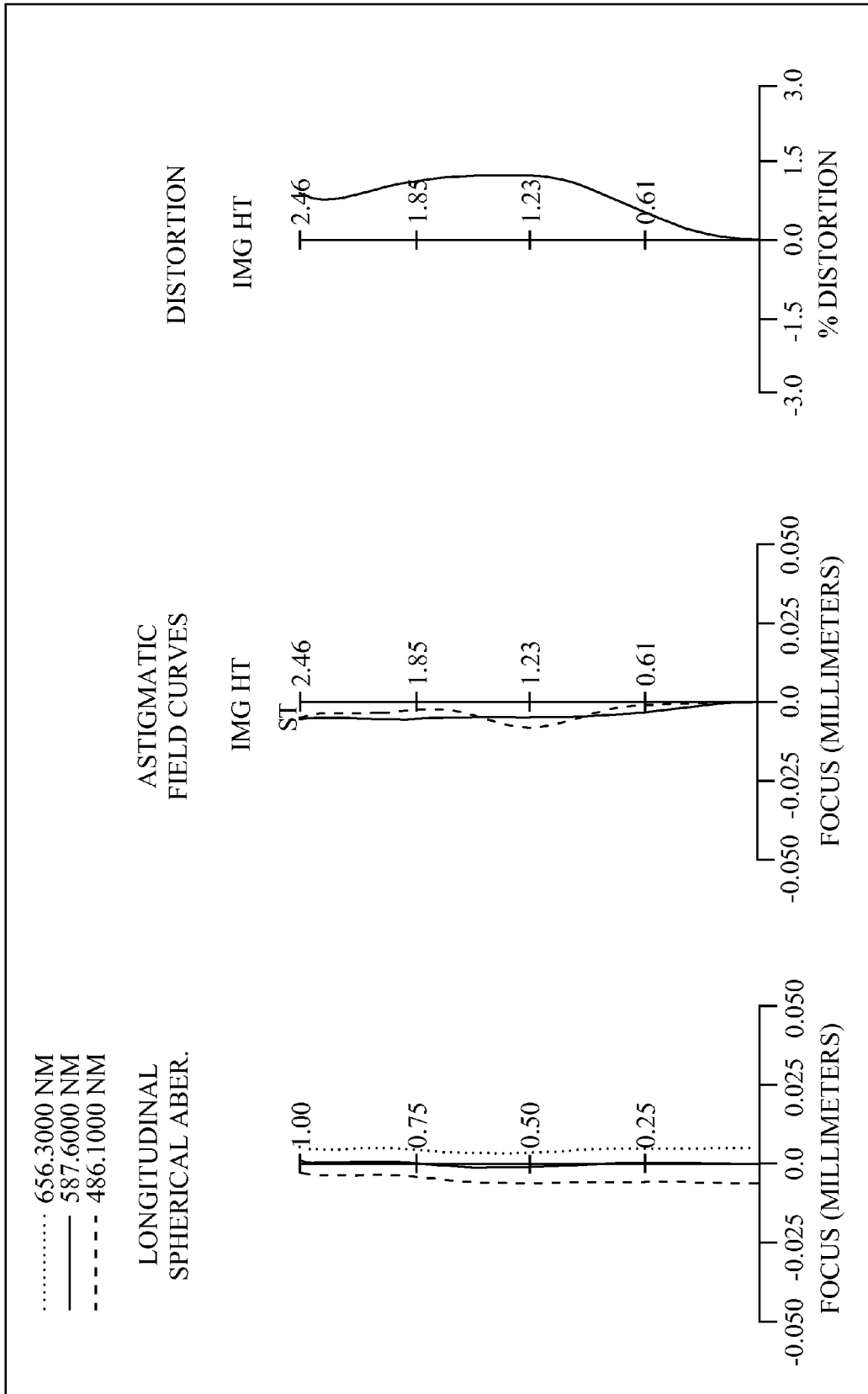

FIG. 6B

OPTICAL LENS FOR IMAGE PICKUP

CROSS-REFERENCE TO RELATED APPLICATION

This application claims the benefit of priority to Taiwan Patent Application No. 100124481, filed on Jul. 11, 2011, in the Taiwan Intellectual Property Office, the disclosure of which is incorporated herein in its entirety by reference.

BACKGROUND OF THE INVENTION

1. Field of the Invention

The present invention relates to an optical lens for image pickup, and more particularly to the optical lens for image pickup comprised of five lens elements with great image quality for applying to electronic products.

2. Description of the Related Art

In compact electronic products such as digital still cameras or mobile phone cameras, an optical lens for image pickup is generally installed for capturing images of an object, and the optical lens for image pickup tends to be developed with a compact design and a low cost, while meeting the user requirements for good aberration correction ability, high resolution, and high image quality.

In general, a conventional optical lens for image pickup of a compact electronic product comes with different designs, including the two-lens, three-lens, four-lens, and five-or-more lens designs. However, if the imaging quality is taken into consideration, the optical lens for image pickup with the four-lens or five-lens designs has advantages on image aberration and modulation transfer function (MTF) performance.

In various compact designs of the five-lens optical lens for image pickup having a fixed focal length, the prior arts adopt different combinations of positive and negative refractive powers. As disclosed in U.S. Pat. No. 7,663,813 which adopts a group of stacked lens elements, in which the two cemented glass lenses incur a higher manufacturing cost, and such conventional optical lens for image pickup is unfavorable for the cost control of mass production. Another conventional technique is the combination of a first lens element with negative refractive power and a second lens element with positive refractive power as disclosed in U.S. Pat. No. 7,480,105, but such conventional optical lens for image pickup cannot reduce the total length of the optical system easily to meet the requirement of the compact design.

Therefore, the present invention provides a more practical design to shorten the optical lens for image pickup, while using a combination of refractive powers and a combination of convex and concave surfaces of five lens elements to lower the cost for mass production easily and apply the optical lens for image pickup to compact electronic products.

SUMMARY OF THE INVENTION

Therefore, it is a primary objective of the present invention to provide an optical lens for image pickup, sequentially arranged from an object side to an image side along an optical axis, comprising: a first lens element, a second lens element, a third lens element, a fourth lens element and a fifth lens element. Wherein the first lens element with positive refractive power has a convex object-side surface; the second lens element has negative refractive power; the third lens element has refractive power; the fourth lens element with positive refractive power is made of plastic, and has a convex object-side surface and a convex image-side surface, and at least one of the object-side surface and the image-side surface is

aspheric; the fifth lens element with negative refractive power is made of plastic and has a concave image-side surface and at least one of the object-side surface and the image-side surface is aspheric, and at least one of the object-side surface and the image-side surface has at least one inflection point, and the following relation is satisfied:

$$-1.0 < R_7/R_8 < 0; \quad (1)$$

wherein, R_7 is the curvature radius of the object-side surface of the fourth lens element, and R_8 is the curvature radius of the image-side surface of the fourth lens element.

On the other hand, the present invention provides an optical lens for image pickup, as described above, wherein the second lens element has a concave image-side surface; and the optical lens for image pickup satisfies one or more of the following relations in addition to the relation (1):

$$0 < f/f_4 < 1.0; \quad (2)$$

$$0 < (R_3 + R_4)/(R_3 - R_4) < 1.8; \quad (3)$$

$$1.2 < f/f_1 < 1.8; \quad (4)$$

$$0.2 < CT_4/CT_5 < 1.4; \quad (5)$$

wherein, f is the focal length of the optical lens for image pickup, f_1 is the focal length of the first lens element, f_4 is the focal length of the fourth lens element, R_3 is the curvature radius of the object-side surface of the second lens element, R_4 is the curvature radius of the image-side surface of the second lens element, CT_4 is the central thickness of the fourth lens element on the optical axis, and CT_5 is the central thickness of the fifth lens element on the optical axis.

On the other hand, the present invention provides an optical lens for image pickup, as described above, wherein the second lens element has a concave image-side surface, and the optical lens for image pickup satisfies one or more of the following relations in addition to the relation (1):

$$1.7 < v_1/v_2 < 3.0; \quad (6)$$

$$0 < R_4/f < 1.5; \quad (7)$$

$$0.2 < CT_2/CT_3 < 0.8; \quad (8)$$

wherein, v_1 is the Abbe number of the first lens element, v_2 is the Abbe number of the second lens element, R_4 is the curvature radius of the image-side surface of the second lens element, f is the focal length of the optical lens for image pickup, CT_2 is the central thickness of the second lens element on the optical axis, and CT_3 is the central thickness of the third lens element on the optical axis.

On the other hand, the present invention provides an optical lens for image pickup, as described above, wherein at least one of the object-side surface and the image-side surface of the fourth lens element has at least one inflection point, and the optical lens for image pickup satisfies the following relation in addition to the relation (1):

$$-1.0 < R_7/R_8 < 0; \quad (9)$$

wherein, R_7 is the curvature radius of the object-side surface of the fourth lens element, and R_8 is the curvature radius of the image-side surface of the fourth lens element.

Another objective of the present invention is to provide an optical lens for image pickup, sequentially arranged from an object side to an image side along an optical axis, comprising: a first lens element, a second lens element, a third lens element, a fourth lens element and a fifth lens element, wherein the first lens element with positive refractive power has a convex object-side surface; the second lens element with

3

negative refractive power has a concave image-side surface; the third lens element with refractive power has a concave object-side surface; the fourth lens element with positive refractive power is made of plastic and has a convex object-side surface and a convex image-side surface, and at least one of the object-side surface and the image-side surface is aspheric; the fifth lens element with negative refractive power is made of plastic and has a concave image-side surface, and at least one of the object-side surface and the image-side surface is aspheric, and at least one of the object-side surface and the image-side surface has at least one inflection point, and the following relations are satisfied:

$$0 < f/f_4 < 1.0; \quad (2)$$

$$0.2 < CT_4/CT_5 < 1.4; \quad (5)$$

wherein, f is the focal length of the optical lens for image pickup, f_4 is the focal length of the fourth lens element, CT_4 is the central thickness of the fourth lens element on the optical axis, and CT_5 is the central thickness of the fifth lens element on the optical axis.

On the other hand, the present invention provides an optical lens for image pickup, as described above, wherein, the third lens element has a convex image-side surface, and the optical lens for image pickup satisfies one or more of the following relations in addition to the relations (2) and (5):

$$1.2 < f/f_1 < 1.8; \quad (4)$$

$$1.7 < v_1/v_2 < 3.0; \quad (6)$$

$$-0.7 < f/R_8 < 0; \quad (10)$$

$$-0.5 < R_7/R_8 < 0; \quad (9)$$

$$0 < (R_3 + R_4)/(R_3 - R_4) < 1.8; \quad (3)$$

wherein, f is the focal length of the optical lens for image pickup, f_1 is the focal length of the first lens element, v_1 is the Abbe number of the first lens element, v_2 is the Abbe number of the second lens element, R_3 is the curvature radius of the object-side surface of the second lens element, R_4 is the curvature radius of the image-side surface of the second lens element, R_7 is the curvature radius of the object-side surface of the fourth lens element, and R_8 is the curvature radius of the image-side surface of the fourth lens element.

Another objective of the present invention is to provide an optical lens for image pickup, sequentially arranged from an object side to an image side along an optical axis, comprising: a first lens element, a second lens element, a third lens element, a fourth lens element and a fifth lens element; wherein the first lens element with positive refractive power has a convex object-side surface; the second lens element with negative refractive power has a concave image-side surface; the third lens element with refractive power has a concave object-side surface and a convex image-side surface; the fourth lens element with positive refractive power is made of plastic and has a convex object-side surface and a convex image-side surface, and at least one of the object-side surface and the image-side surface is aspheric; the fifth lens element with negative refractive power is made of plastic and at least one of the object-side surface and the image-side surface is aspheric, and at least one of the object-side surface and the image-side surface has at least one inflection point, and the following relations are satisfied:

$$0 < f/f_4 < 1.0; \quad (2)$$

$$0 < R_4/f < 1.5; \quad (7)$$

$$-0.7 < f/R_8 < 0; \quad (10)$$

4

wherein, f is the focal length of the optical lens for image pickup, f_4 is the focal length of the fourth lens element, R_4 is the curvature radius of the image-side surface of the second lens element, and R_8 is the curvature radius of the image-side surface of the fourth lens element.

On the other hand, the present invention provides an optical lens for image pickup, as described above, wherein the optical lens for image pickup satisfies one or more of the following relations in addition to the relations (2), (7) and (10):

$$1.7 < v_1/v_2 < 3.0; \quad (6)$$

$$0.2 < CT_4/CT_5 < 1.4; \quad (5)$$

$$1.2 < f/f_1 < 1.8; \quad (4)$$

$$0.2 < CT_2/CT_3 < 0.8; \quad (8)$$

wherein, v_1 is the Abbe number of the first lens element, v_2 is the Abbe number of the second lens element, f is the focal length of the optical lens for image pickup, f_1 is the focal length of the first lens element, CT_2 is the central thickness of the second lens element on the optical axis, CT_3 is the central thickness of the third lens element on the optical axis, CT_4 is the central thickness of the fourth lens element on the optical axis, and CT_5 is the central thickness of the fifth lens element on the optical axis.

In the optical lens for image pickup of the present invention, the optical lens for image pickup comprises a first lens element, a second lens element, a third lens element, a fourth lens element and a fifth lens element. Wherein the first lens element provides most of the refractive power required by the system, and the second lens element with negative refractive power can correct aberrations produced by the lens element with positive refractive power effectively and correct the Petzval sum of the system to make the image surface on the edge flatter. If the second lens element has a concave image-side surface, the intensity of the negative refractive power of the second lens element can be adjusted appropriately according to the surface shape to provide a good aberration correction effect for the system. If the third lens element is a meniscus lens element having a concave object-side surface and a convex image-side surface, the effect of correcting astigmatism can be improved. If the curvature at the position of the periphery is greater than the curvature at the center of the image-side surface, the angle of the incident light from the periphery of the system can be suppressed within a range of projecting onto the sensor to improve the light sensitivity of the image sensor. In addition, the supplementary installation of the fourth lens element with positive refractive power and the fifth lens element with negative refractive power can produce a telecentric effect to facilitate reducing the focal length and the total length of the optical system. If the fourth lens element has a convex image-side surface, the correction of the astigmatism and the high-order aberration of the optical lens for image pickup can be improved. If the fifth lens element has a concave image-side surface, the principal point of the optical system can be maintained at a position far from the image plane to facilitate reducing the total length of optical imaging lens assembly and miniaturizing the size of the optical system. With such configuration of the optical lens for image pickup, the image sensor can achieve a greater effective pixel range with the same total length.

If the fifth lens element has an inflection point, the inflection point can be used for guiding the image light projecting out the edge of the fifth lens element at an angle, such that the image light is guided to the image sensor at the off-axis view angle and received by the image sensor. In addition, the fourth

lens element and the fifth lens element are made of plastic to facilitate the manufacture and lower the cost.

BRIEF DESCRIPTION OF THE DRAWINGS

FIG. 1A is a schematic view of an optical lens for image pickup in accordance with the first preferred embodiment of the present invention;

FIG. 1B is a schematic view of a series of aberration curves of the first preferred embodiment of the present invention;

FIG. 2A is a schematic view of an optical lens for image pickup in accordance with the second preferred embodiment of the present invention;

FIG. 2B is a schematic view of a series of aberration curves of the second preferred embodiment of the present invention;

FIG. 3A is a schematic view of an optical lens for image pickup in accordance with the third preferred embodiment of the present invention;

FIG. 3B is a schematic view of a series of aberration curves of the third preferred embodiment of the present invention;

FIG. 4A is a schematic view of an optical lens for image pickup in accordance with the fourth preferred embodiment of the present invention;

FIG. 4B is a schematic view of a series of aberration curves of the fourth preferred embodiment of the present invention;

FIG. 5A is a schematic view of an optical lens for image pickup in accordance with the fifth preferred embodiment of the present invention;

FIG. 5B is a schematic view of a series of aberration curves of the fifth preferred embodiment of the present invention;

FIG. 6A is a schematic view of an optical lens for image pickup in accordance with the sixth preferred embodiment of the present invention; and

FIG. 6B is a schematic view of a series of aberration curves of the sixth preferred embodiment of the present invention.

DETAILED DESCRIPTION OF THE PREFERRED EMBODIMENTS

With reference to FIG. 1A, the present invention provides an optical lens for image pickup, sequentially arranged from an object side to an image side along an optical axis, comprising: a first lens element **110**, a second lens element **120**, a third lens element **130**, a fourth lens element **140** and a fifth lens element **150**; wherein the first lens element **110** with positive refractive power has a convex object-side surface **111**; the second lens element **120** has negative refractive power; the third lens element **130** has refractive power; the fourth lens element **140** with positive refractive power is made of plastic and has a convex object-side surface **141** and a convex image-side surface **142**, and at least one of the object-side surface **141** and the image-side surface **142** is aspheric; the fifth lens element **150** with negative refractive power is made of plastic, and has a concave image-side surface **152**, and at least one of the object-side surface **151** and the image-side surface **152** is aspheric, and at least one of the object-side surface **151** and the image-side surface **152** has at least one inflection point. The optical lens for image pickup further comprises a stop and an IR-filter **160**, and the stop can be an aperture stop **100**, which is a front aperture stop installed between a photographed object and the first lens element **110**. The IR-filter **160** is installed between the fifth lens element **150** and the image plane **170** generally made of a panel optical material without affecting the focal length of the optical lens for image pickup of the present invention. The aspheric surfaces of the first lens element **110**, the second lens element **120**, the third lens element **130**, the fourth lens ele-

ment **140** and the fifth lens element **150** comply with the aspherical surface formula as given in Equation (11).

$$X(Y) = \frac{(Y^2/R)}{1 + \sqrt{1 - (1 + K)(Y/R)^2}} + \sum_i (A_i) \cdot (Y^i) \quad (11)$$

Wherein,

X is the relative height from a point on the aspherical surface with a distance Y between the optical axis and a tangent plane at the tip of the optical axis of the aspherical surface;

Y is the distance between a point on the curve of the aspherical surface and the optical axis;

R is the curvature radius;

K is the conic coefficient; and

A_i is the i^{th} level aspherical surface coefficient.

In the optical lens for image pickup of the present invention, the first lens element **110**, second lens element **120**, and third lens element **130** have aspheric surfaces, the curvature radius of the optical surface can be used for changing the refractive power to reduce or eliminate aberrations, so as to reduce the number of lenses used in the optical lens for image pickup and reduce the total length of the optical lens for image pickup effectively. With the installation of the first lens element **110**, second lens element **120**, third lens element **130**, fourth lens element **140**, and fifth lens element **150**, the optical lens for image pickup satisfies the relation (1).

In the optical lens for image pickup of the present invention, the major positive refractive power is provided by the first lens element **110** and the fourth lens element **140**. If the ratio of the curvature radius R_7 of the object-side surface **141** of the fourth lens element **140** to the curvature radius R_8 of the image-side surface **142** is limited according to the relation (1), the variation of surface shape of the object-side surface **141** and the image-side surface **142** of the fourth lens element **140** can be limited, not only facilitating the correction of the spherical aberration of the fourth lens element **140**, but also appropriately adjusting the complementary correction of the refractive power of the fourth lens element **140** and the refractive power of the fifth lens element **150** if the relation (2) is satisfied, such that the telecentric effect is produced to facilitate reduction of the focal length and the total length, thereby achieving the effect of miniaturizing the lens.

If the relation (10) is satisfied, the curvature radius R_8 of the image-side surface **142** of the fourth lens element **140** is greater than the focal length f of the optical lens for image pickup to facilitate limiting the positive refractive power of the fourth lens element **140** in order to compensate the near-axis aberration more easily. If the ratio of the focal length f_1 of the first lens element **110** to the focal length f of the optical lens for image pickup is limited according to the relation (4), the positive refractive power of the first lens element **110** can be allocated appropriately to adjust the focal length of the optical system and reduce the total length appropriately. If the relation (7) is satisfied, and the second lens element **120** has a concave image-side surface **122**, the curvature radius R_4 of the image-side surface **122** of the second lens element **120** is smaller than the focal length f of the optical lens for image pickup, which facilitates increasing the refractive power of the second lens element **120** and compensating the near-axis aberration more easily. If the ratio in the relation is too large,

then the negative refractive power is relatively weaker, and the chromatic aberration correction ability becomes weaker. If the ratio in the relation is too small, then the negative refractive power is relatively stronger, so that the total length cannot be reduced effectively, so that if this relation is limited within an appropriate range, the effects of correcting the aberration and reducing the total length can be achieved to facilitate the allocation of the refractive power of the first lens element **110** and the second lens element **120**.

If the ratio of the curvature radius R_3 of the object-side surface **121** of the second lens element **120** to the curvature radius R_4 of the image-side surface **122** is limited according to the relations (3), the change of the surface shape of the second lens element **120** can be limited to facilitate the aberration correction function of the second lens element **120** with negative refractive power. In addition, the fourth lens element **140** has a convex image-side surface **142**. If the ratio of the curvature radius of the object-side surface **141** to the curvature radius of the image-side surface **142** is limited according to the relation (9), the refractive power of the fourth lens element **140** can be allocated appropriately to achieve the effects of reducing the sensitivity of the manufacture, improving the yield rate, and saving the production cost.

If the relation (6) is satisfied, the difference between the Abbe number v_1 of the first lens element **110** and the Abbe number v_2 of the second lens element **120** falls within an appropriate range, and the chromatic aberration produced by the first lens element **110** and the second lens element **120** can be corrected effectively. If the relation (5) or (8) is satisfied, the thickness of the second lens element **120**, third lens element **130**, fourth lens element **140** and fifth lens element **150** can be adjusted to facilitate reduction of the total length of the optical lens for image pickup, and the optical lens for image pickup thick enough to maintain the yield rate of the manufacturing process.

The optical lens for image pickup of the present invention is described by means of preferred embodiments with relevant drawings as follows.

First Preferred Embodiment

With reference to FIGS. 1A and 1B for a schematic view and a series of aberration curves of an optical lens for image pickup in accordance with the first preferred embodiment of the present invention respectively, the optical lens for image pickup comprises five lens elements, an aperture stop **100** and an IR-filter **160**. More specifically, the optical lens for image pickup of the present invention, sequentially arranged from an object side to an image side along an optical axis, comprises: a plastic first lens element **110** with positive refractive power, having a convex object-side surface **111** and a convex image-side surface **112**, and both object-side surface **111** and image-side surface **112** being aspheric; an aperture stop **100**; a plastic second lens element **120** with negative refractive power, having a concave object-side surface **121** and a concave image-side surface **122**, and both object-side surface **121** and image-side surface **122** being aspheric; a plastic third lens element **130** with negative refractive power, having a concave object-side surface **131** and a convex image-side surface **132**, and both object-side surface **131** and image-side surface **132** being aspheric; a plastic fourth lens element **140** with positive refractive power, having a convex object-side surface **141** and a convex image-side surface **142**, and both object-side surface **141** and image-side surface **142** being aspheric; a plastic fifth lens element **150** with negative refractive power, having a convex object-side surface **151** and a concave image-side surface **152**, both object-side surface **151** and image-side surface **152** being aspheric, and at least one of the object-side surface **151** and the image-side surface **152** having at least one inflection point; and an IR-filter **160** made of panel glass for adjusting a wavelength section of the light of an image. With the combination of the five lens elements, the aperture stop **100** and the IR-filter **160**, an image of the photographed object can be formed at the image plane **170**.

TABLE 1

Optical data of this preferred embodiment							
f = 4.30 mm, Fno = 2.60, HFOV = 32.5 deg.							
Surface #		Curvature Radius	Thickness	Material	Index	Abbe #	Focal length
0	Object	Plano	Infinity				
1	Lens 1	1.543340 (ASP)	0.565	Plastic	1.544	55.9	2.76
2		-50.020500 (ASP)	-0.006				
3	Ape. Stop	Plano	0.149	Plastic	1.634	23.8	-5.16
4		-28.968700 (ASP)	0.250				
5	Lens 2	3.696800 (ASP)	0.526	Plastic	1.634	23.8	-17.54
6		-1.997210 (ASP)	0.374				
7	Lens 3	-2.611270 (ASP)	0.144	Plastic	1.544	55.9	10.50
8		7.082200 (ASP)	0.433				
9	Lens 4	-28.985500 (ASP)	0.659	Plastic	1.544	55.9	-20.77
10		1.318510 (ASP)	0.406				
11	Lens 5	1.052660 (ASP)	0.700	Plastic	1.544	55.9	-20.77
12		Plano	0.300				
13	IR-filter	Plano	0.512	Glass	1.517	64.2	—
14	Image	Plano	—				

Note:

Reference wavelength is 587.6 nm. ASP stands for aspherical surfaces.

The optical data of this preferred embodiment are listed in Table 1, wherein the object-side surfaces and the image-side surfaces of the first lens element **110** to the fifth lens element **150** comply with the aspheric surface formula as given in Equation (11), and their aspheric coefficients are listed in Table 2 as follows:

TABLE 2

Aspheric coefficients of this preferred embodiment					
	Surface #				
	1	2	4	5	6
k =	-3.06355E-01	-3.00000E+01	-2.00000E+01	2.88304E+00	4.27633E-02
A4 =	2.50446E-03	-4.94200E-02	-6.14490E-03	4.99730E-02	-7.67470E-02
A6 =	-1.55993E-02	2.47780E-02	9.23046E-02	4.34781E-02	2.50419E-02
A8 =	1.52702E-02	-2.25423E-02	-1.89711E-02	9.45095E-02	-3.96334E-02
A10 =	-4.34215E-02	-2.73589E-02	-6.14602E-03	-1.62870E-01	3.46322E-02
A12 =		2.53422E-02	3.76475E-02	1.56936E-01	-2.39569E-02
	Surface #				
	7	8	9	10	11
k =	2.87761E+00	-2.00000E+01	-2.00000E+01	-6.29779E+00	-4.56785E+00
A4 =	-8.66151E-02	-5.08900E-02	-1.28834E-02	-7.52268E-02	-5.78631E-02
A6 =	6.72960E-02	8.88439E-03	-3.94794E-03	8.16349E-03	1.00587E-02
A8 =	-1.73962E-02	-4.10142E-04	8.50755E-04	3.31543E-04	-1.68186E-03
A10 =	1.33287E-02	-6.15772E-04	8.77634E-05	-6.50499E-05	3.97827E-05
A12 =	1.68817E-03	2.04068E-04	-6.24845E-05		2.08062E-05
A14 =					-1.24326E-06

With reference to Table 1 and FIG. 1B for an optical lens for image pickup of this preferred embodiment, the optical lens for image pickup has a focal length $f=4.30$ (mm), an overall aperture stop value (f-number) $Fno=2.60$, and a half of the maximum view angle $HFOV=32.5^\circ$. After the optical data of this preferred embodiment are calculated and derived, the optical imaging system for pickup satisfies related conditions as shown in Table 3 below, and the related symbols have been described above and thus will not be described again.

TABLE 3

Data of related relations of this preferred embodiment			
Relation	Data	Relation	Data
V_1/V_2	2.35	R_7/R_8	-0.24
CT_2/CT_3	0.67	$(R_3 + R_4)/(R_3 - R_4)$	0.77
CT_4/CT_5	1.07	f/f_1	1.56
R_4/f	0.86	f/f_4	0.41
f/R_8	-0.15		

According to the optical data as shown in Table 1 and the series of aberration curves as shown in FIG. 1B, the optical lens for image pickup in accordance with this preferred embodiment of the present invention provides good correction results in aspects of the longitudinal spherical aberration, astigmatic field curving, and distortion.

Second Preferred Embodiment

With reference to FIGS. 2A and 2B for a schematic view and a series of aberration curves of an optical lens for image

pickup in accordance with the second preferred embodiment of the present invention respectively, the optical lens for image pickup comprises five lens elements, an aperture stop **200** and an IR-filter **260**. More specifically, the optical lens for image pickup of the present invention, sequentially arranged

from an object side to an image side along an optical axis, comprises: an aperture stop **200**; a plastic first lens element **210** with positive refractive power, having a convex object-side surface **211** and a concave image-side surface **212**, and both object-side surface **211** and image-side surface **212** being aspheric; a plastic second lens element **220** with negative refractive power, having a convex object-side surface **221** and a concave image-side surface **222**, and both object-side surface **221** and image-side surface **222** being aspheric; a plastic third lens element **230** with negative refractive power, having a concave object-side surface **231** and a convex image-side surface **232**, and both object-side surface **231** and image-side surface **232** being aspheric; a plastic fourth lens element **240** with positive refractive power, having a convex object-side surface **241** and a convex image-side surface **242**, and both object-side surface **241** and image-side surface **242** being aspheric; a plastic fifth lens element **250** with negative refractive power, having a convex object-side surface **251** and a concave image-side surface **252**, and both object-side surface **251** and image-side surface **252** being aspheric, and at least one of the object-side surface **251** and the image-side surface **252** having at least one inflection point; and an IR-filter **260** made of panel glass for adjusting a wavelength section of the light of an image. With the combination of the five lens elements, the aperture stop **200** and the IR-filter **260**, an image of the photographed object can be formed at the image plane **270**.

TABLE 4

Optical data of this preferred embodiment f = 4.05 mm, Fno = 2.60, HFOV = 34.3 deg.							
Surface #		Curvature Radius	Thickness	Material	Index	Abbe #	Focal length
0	Object	Plano	Infinity				
1	Ape. Stop	Plano	-0.194				
2		1.506920 (ASP)	0.496				
	Lens 1			Plastic	1.544	55.9	2.85
3		48.167000 (ASP)	0.114				
4		12.736100 (ASP)	0.250				
	Lens 2			Plastic	1.634	23.8	-5.62
5		2.763530 (ASP)	0.490				
6		-1.891750 (ASP)	0.323				
	Lens 3			Plastic	1.634	23.8	-9.92
7		-2.884420 (ASP)	0.097				
8		5.273100 (ASP)	0.477				
	Lens 4			Plastic	1.544	55.9	7.61
9		-18.719600 (ASP)	0.548				
10		1.287060 (ASP)	0.404				
	Lens 5			Plastic	1.544	55.9	-147.94
11		1.126680 (ASP)	0.700				
12		Plano	0.300				
	IR-filter			Glass	1.517	64.2	—
13		Plano	0.624				
14	Image	Plano	—				

Note:
Reference wavelength is 587.6 nm. ASP stands for aspherical surfaces.

The optical data of this preferred embodiment are listed in Table 4, wherein the object-side surfaces and the image-side surfaces of the first lens element 210 to the fifth lens element 250 comply with the aspheric surface formula as given in Equation (11), and their aspheric coefficients are listed in Table 5 as follows:

TABLE 5

Aspheric coefficients of this preferred embodiment					
	Surface #				
	2	3	4	5	6
k =	-2.90585E-01	9.96023E+00	-2.00000E+01	2.49495E+00	-7.07887E-01
A4 =	3.37557E-03	-5.04837E-02	-1.20356E-02	4.51108E-02	-5.47589E-02
A6 =	-1.50709E-02	1.96828E-02	8.29217E-02	4.24263E-02	2.55587E-02
A8 =	1.20870E-02	-2.39993E-02	-2.65473E-02	9.10951E-02	-3.40833E-02
A10 =	-5.71916E-02	-3.33644E-02	-6.80586E-03	-1.65955E-01	4.12585E-02
A12 =		1.23073E-02	4.80467E-02	1.64550E-01	-2.83912E-02
	Surface #				
	7	8	9	10	11
k =	3.10741E+00	-7.17143E+00	-2.00000E+01	-3.88861E+00	-3.41767E+00
A4 =	-9.59479E-02	-5.27367E-02	-4.11369E-03	-8.40582E-02	-6.99738E-02
A6 =	7.13936E-02	9.03915E-03	-6.85160E-03	7.75131E-03	1.19781E-02
A8 =	-1.75694E-02	-9.53755E-04	8.78711E-04	5.42326E-04	-1.74102E-03
A10 =	1.27269E-02	-6.83563E-04	2.08012E-04	-8.36623E-05	1.87210E-05
A12 =	1.49857E-03	3.97972E-04	-6.10219E-05		1.98415E-05
A14 =					-1.05144E-06

With reference to Table 4 and FIG. 2B for an optical lens for image pickup of this preferred embodiment, the optical lens for image pickup has a focal length f=4.05 (mm), an overall aperture stop value (f-number) Fno=2.60, and a half of the maximum view angle HFOV=34.3°. After the optical data of this preferred embodiment are calculated and derived, the optical imaging system for pickup satisfies related conditions as shown in Table 6 below, and the related symbols have been described above and thus will not be described again.

TABLE 6

Data of related relations of this preferred embodiment			
Relation	Data	Relation	Data
v_1/v_2	2.35	R_7/R_8	-0.28
CT_2/CT_3	0.77	$(R_3 + R_4)/(R_3 - R_4)$	1.55
CT_4/CT_5	1.18	f/f_1	1.42

TABLE 6-continued

Data of related relations of this preferred embodiment			
Relation	Data	Relation	Data
R_4/f	0.68	f/f_4	0.53
f/R_8	-0.22		

According to the optical data as shown in Table 4 and the series of aberration curves as shown in FIG. 2B, the optical lens for image pickup in accordance with this preferred embodiment of the present invention provides good correction results in aspects of the longitudinal spherical aberration, astigmatic field curving, and distortion.

Third Preferred Embodiment

With reference to FIGS. 3A and 3B for a schematic view and a series of aberration curves of an optical lens for image pickup in accordance with the third preferred embodiment of the present invention respectively, the optical lens for image pickup comprises five lens elements, an aperture stop 300 and an IR-filter 360. More specifically, the optical lens for image pickup of the present invention, sequentially arranged from an object side to an image side along an optical axis, comprises: a plastic first lens element 310 with positive refractive

power, having a convex object-side surface 311 and a convex image-side surface 312, and both object-side surface 311 and image-side surface 312 being aspheric; an aperture stop 300; a plastic second lens element 320 with negative refractive power, having a concave object-side surface 321 and a concave image-side surface 322, and both object-side surface 321 and image-side surface 322 being aspheric; a plastic third lens element 330 with positive refractive power, having a concave object-side surface 331 and a convex image-side surface 332, and both object-side surface 331 and image-side surface 332 being aspheric; a plastic fourth lens element 340 with positive refractive power, having a convex object-side surface 341 and a convex image-side surface 342, and both object-side surface 341 and image-side surface 342 being aspheric; a plastic fifth lens element 350 with negative refractive power, having a concave object-side surface 351 and a concave image-side surface 352, and both object-side surface 351 and image-side surface 352 being aspheric, and at least one of the object-side surface 351 and the image-side surface 352 having at least one inflection point; and an IR-filter 360 made of panel glass for adjusting a wavelength section of the light of an image. With the combination of the five lens elements, the aperture stop 300 and the IR-filter 360, an image of the photographed object can be formed at the image plane 370.

TABLE 7

Optical data of this preferred embodiment							
$f = 4.71 \text{ mm}$, $Fno = 3.50$, $HFOV = 28.0 \text{ deg.}$							
Surface #		Curvature Radius	Thickness	Material	Index	Abbe #	Focal length
0	Object	Plano	Infinity				
1		1.614961 (ASP)	0.575				
2	Lens 1	-75.802175 (ASP)	0.082	Plastic	1.544	55.9	2.91
3	Ape. Stop	Plano	0.115				
4		-41.465666 (ASP)	0.300				
5	Lens 2	2.622202 (ASP)	0.189	Plastic	1.634	23.8	-3.88
6		-12.279317 (ASP)	0.755				
7	Lens 3	-2.761231 (ASP)	0.333	Plastic	1.544	55.9	6.37
8		11.494253 (ASP)	0.353				
9	Lens 4	-52.356021 (ASP)	0.596	Plastic	1.607	26.6	15.55
10		-4.528541 (ASP)	0.940				
11	Lens 5	3.292141 (ASP)	0.400	Plastic	1.535	56.3	-3.42
12		Plano	0.210				
13	IR-filter			Glass	1.517	64.2	—
14	Image	Plano	0.384				

Note:

Reference wavelength is 587.6 nm. ASP stands for aspherical surfaces.

The optical data of this preferred embodiment are listed in Table 7, wherein the object-side surfaces and the image-side surfaces of the first lens element 310 to the fifth lens element 350 comply with the aspheric surface formula as given in Equation (11), and their aspheric coefficients are listed in Table 8 as follows:

TABLE 8

Aspheric coefficients of this preferred embodiment					
Surface #					
	1	2	4	5	6
k =	3.77232E-01	2.00000E+01	-2.00000E+01	2.83420E+00	9.93468E+00
A4 =	-5.22870E-03	-1.75425E-02	-1.21265E-01	-1.29426E-01	-9.55645E-02
A6 =	6.96863E-03	1.17248E-02	1.55859E-01	9.41042E-02	-1.99603E-01
A8 =	-2.65604E-02	4.20783E-02	-1.90005E-01	7.51996E-03	5.27565E-01
A10 =	4.52653E-02	-1.18182E-01	3.92269E-01	-3.64954E-02	-1.18794E+00
A12 =	-3.33437E-02	7.28858E-02	-4.44021E-01	3.07005E-01	1.43618E+00
Surface #					
	7	8	9	10	11
k =	-3.43499E+00	-1.99975E+01	-1.97680E+01	-1.83019E+01	-1.53251E+01
A4 =	-1.11705E-01	-4.79359E-02	-3.18944E-02	-2.08847E-01	-8.60770E-02
A6 =	-4.64337E-02	-4.82513E-02	-3.06928E-02	3.31188E-02	2.54167E-02
A8 =	5.15033E-02	8.33360E-02	7.70559E-02	1.41605E-02	-6.30106E-03
A10 =	-9.87530E-03	-1.77482E-02	-4.24349E-02	-3.43286E-03	7.08448E-04
A12 =	2.62131E-03	-1.07602E-02	1.21395E-02	-4.42682E-03	2.17917E-05
A14 =		2.96551E-03	-2.39441E-03	-1.10330E-03	-2.35145E-05
A16 =				8.47509E-04	2.64648E-06

35

With reference to Table 7 and FIG. 31B for an optical lens for image pickup of this preferred embodiment, the optical lens for image pickup has a focal length $f=4.71$ (mm), an overall aperture stop value (f-number) $Fno=3.50$, and a half of the maximum view angle $HFOV=28.0^\circ$. After the optical data of this preferred embodiment are calculated and derived, the optical imaging system for pickup satisfies related conditions as shown in Table 9 below, and the related symbols have been described above and thus will not be described again.

TABLE 9

Data of related relations of this preferred embodiment			
Relation	Data	Relation	Data
v_1/v_2	2.35	R_7/R_8	-0.22
CT_2/CT_3	0.40	$(R_3 + R_4)/(R_3 - R_4)$	0.88
CT_4/CT_5	0.38	f/f_1	1.62
R_4/f	0.56	f/f_4	0.30
f/R_8	-0.09		

50

According to the optical data as shown in Table 7 and the series of aberration curves as shown in FIG. 3B, the optical lens for image pickup in accordance with this preferred embodiment of the present invention provides good correction results in aspects of the longitudinal spherical aberration, astigmatic field curving, and distortion.

Fourth Preferred Embodiment

With reference to FIGS. 4A and 4B for a schematic view and a series of aberration curves of an optical lens for image

65

pickup in accordance with the fourth preferred embodiment of the present invention respectively, the optical lens for image pickup comprises five lens elements, an aperture stop 400 and an IR-filter 460. More specifically, the optical lens for image pickup of the present invention, sequentially arranged

from an object side to an image side along an optical axis, comprises: a plastic first lens element 410 with positive refractive power, having a convex object-side surface 411 and a concave image-side surface 412, and both object-side surface 411 and image-side surface 412 being aspheric; an aperture stop 400; a plastic second lens element 420 with negative refractive power, having a convex object-side surface 421 and a concave image-side surface 422, and both object-side surface 421 and image-side surface 422 being aspheric; a plastic third lens element 430 with positive refractive power, having a concave object-side surface 431 and a convex image-side surface 432, and both object-side surface 431 and image-side surface 432 being aspheric; a plastic fourth lens element 440 with positive refractive power, having a convex object-side surface 441 and a convex image-side surface 442, and both object-side surface 441 and image-side surface 442 being aspheric; a plastic fifth lens element 450 with negative refractive power, having a concave object-side surface 451 and a concave image-side surface 452, and both object-side surface 451 and image-side surface 452 being aspheric, and at least one of the object-side surface 451 and the image-side surface 452 having at least one inflection point; and an IR-filter 460 made of panel glass for adjusting a wavelength section of the light of an image. With the combination of the five lens elements, the aperture stop 400 and the IR-filter 460, an image of the photographed object can be formed at the image plane 470.

TABLE 10

Optical data of this preferred embodiment f = 4.53 mm, Fno = 3.22, HFOV = 29.2 deg.							
Surface #		Curvature Radius	Thickness	Material	Index	Abbe #	Focal length
0	Object	Plano	Infinity				
1	Lens 1	1.514160 (ASP)	0.577	Plastic	1.544	55.9	3.01
2		17.543860 (ASP)	0.074				
3	Ape. Stop	Plano	0.102	Plastic	1.634	23.8	-4.01
4		17.737217 (ASP)	0.300				
5	Lens 2	2.208734 (ASP)	0.189	Plastic	1.544	55.9	6.13
6		-15.360763 (ASP)	0.780				
7	Lens 3	-2.790952 (ASP)	0.287	Plastic	1.607	26.6	18.72
8		12.987013 (ASP)	0.400				
9	Lens 4	-90.090090 (ASP)	0.559	Plastic	1.535	56.3	-3.79
10		-10.474284 (ASP)	0.867				
11	Lens 5	2.581608 (ASP)	0.400	Glass	1.517	64.2	—
12		Plano	0.210				
13	IR-filter	Plano	0.385				
14	Image	Plano	—				

Note:
Reference wavelength is 587.6 nm. ASP stands for aspherical surfaces.

The optical data of this preferred embodiment are listed in Table 10, wherein the object-side surfaces and the image-side surfaces of the first lens element 410 to the fifth lens element 450 comply with the aspheric surface formula as given in Equation (11), and their aspheric coefficients are listed in Table 11 as follows:

TABLE 11

Aspheric coefficients of this preferred embodiment					
	Surface #				
	1	2	4	5	6
k =	4.33467E-01	-1.55764E+01	-2.22007E+02	1.36817E+00	-2.00000E+01
A4 =	-4.31086E-03	-1.92155E-02	-1.46656E-01	-1.38578E-01	-8.33916E-02
A6 =	1.17717E-02	2.62316E-02	1.43155E-01	8.33036E-02	-2.05246E-01
A8 =	-2.12038E-02	3.79660E-02	-1.78028E-01	-1.57603E-02	5.19052E-01
A10 =	3.66170E-02	-8.77626E-02	3.53989E-01	-2.21605E-02	-1.21057E+00
A12 =	-1.25855E-02	4.73149E-02	-4.03871E-01	2.34487E-01	1.39276E+00
	Surface #				
	7	8	9	10	11
k =	-3.38929E+00	-2.00000E+01	2.00000E+01	-2.00000E+01	-1.05408E+01
A4 =	-1.09889E-01	-4.83088E-02	-3.12307E-02	-1.98321E-01	-9.13884E-02
A6 =	-3.96557E-02	-4.77036E-02	-2.99784E-02	3.36464E-02	2.78482E-02
A8 =	5.13883E-02	8.46369E-02	7.67749E-02	1.88927E-02	-6.62067E-03
A10 =	-7.41303E-03	-1.69914E-02	-4.28530E-02	-2.75259E-03	7.01131E-04
A12 =	1.00431E-02	-1.09091E-02	1.23684E-02	-3.93993E-03	2.85277E-05
A14 =		3.31574E-03	-1.91642E-03	-8.14534E-04	-2.24962E-05
A16 =				8.67020E-04	2.18414E-06

With reference to Table 10 and FIG. 4B for an optical lens for image pickup of this preferred embodiment, the optical lens for image pickup has a focal length f=4.53 (mm), an overall aperture stop value (f-number) Fno=3.22, and a half of the maximum view angle HFOV=29.2°. After the optical data of this preferred embodiment are calculated and derived, the optical imaging system for pickup satisfies related conditions as shown in Table 12 below, and the related symbols have been described above and thus will not be described again.

TABLE 12

Data of related relations of this preferred embodiment			
Relation	Data	Relation	Data
v_1/v_2	2.35	R_7/R_8	-0.14
CT_2/CT_3	0.38	$(R_3 + R_4)/(R_3 - R_4)$	1.28
CT_4/CT_5	0.46	f/f_1	1.51

TABLE 12-continued

Data of related relations of this preferred embodiment			
Relation	Data	Relation	Data
R_4/f	0.49	f/f_4	0.24
f/R_8	-0.05		

According to the optical data as shown in Table 10 and the series of aberration curves as shown in FIG. 4B, the optical lens for image pickup in accordance with this preferred embodiment of the present invention provides good correction results in aspects of the longitudinal spherical aberration, astigmatic field curving, and distortion.

Fifth Preferred Embodiment

With reference to FIGS. 5A and 5B for a schematic view and a series of aberration curves of an optical lens for image pickup in accordance with the fifth preferred embodiment of the present invention respectively, the optical lens for image pickup comprises five lens elements, an aperture stop 500 and an IR-filter 560. More specifically, the optical lens for image

a plastic second lens element 520 with negative refractive power, having a convex object-side surface 521 and a concave image-side surface 522, and both object-side surface 521 and image-side surface 522 being aspheric; a plastic third lens element 530 with positive refractive power, having a concave object-side surface 531 and a convex image-side surface 532, and both object-side surface 531 and image-side surface 532 being aspheric; a plastic fourth lens element 540 with positive refractive power, having a convex object-side surface 541 and a convex image-side surface 542, and both object-side surface 541 and image-side surface 542 being aspheric; a plastic fifth lens element 550 with negative refractive power, having a concave object-side surface 551 and a concave image-side surface 552, and both object-side surface 551 and image-side surface 552 being aspheric, and at least one of the object-side surface 551 and the image-side surface 552 having at least one inflection point; and an IR-filter 560 made of panel glass for adjusting a wavelength section of the light of an image. With the combination of the five lens elements, the aperture stop 500 and the IR-filter 560, an image of the photographed object can be formed at the image plane 570.

TABLE 13

Optical data of this preferred embodiment f = 4.48 mm, Fno = 3.22, HFOV = 28.7 deg.							
Surface #		Curvature Radius	Thickness	Material	Index	Abbe #	Focal length
0	Object	Plano	Infinity				
1	Lens 1	1.708317 (ASP)	0.562	Plastic	1.544	55.9	3.06
2		-58.917670 (ASP)	0.073				
3	Ape. Stop	Plano	0.074				
4		8.998329 (ASP)	0.382				
	Lens 2			Plastic	1.634	23.8	-4.15
5		2.001436 (ASP)	0.209				
6		-7.567571 (ASP)	0.780				
	Lens 3			Plastic	1.535	56.3	5.22
7		-2.111134 (ASP)	0.304				
8		35.714286 (ASP)	0.425				
	Lens 4			Plastic	1.607	26.6	35.47
9		-54.020176 (ASP)	0.590				
10		-12.568290 (ASP)	0.786				
	Lens 5			Plastic	1.535	56.3	-3.76
11		2.442242 (ASP)	0.400				
12		Plano	0.210				
	IR-filter			Glass	1.517	64.2	—
13		Plano	0.385				
14	Image	Plano	—				

Note:
Reference wavelength is 587.6 nm. ASP stands for aspherical surfaces.

pickup of the present invention, sequentially arranged from an object side to an image side along an optical axis, comprises: a plastic first lens element 510 with positive refractive power, having a convex object-side surface 511 and a convex image-side surface 512, and both object-side surface 511 and image-side surface 512 being aspheric; an aperture stop 500;

The optical data of this preferred embodiment are listed in Table 13, wherein the object-side surfaces and the image-side surfaces of the first lens element 510 to the fifth lens element 550 comply with the aspheric surface formula as given in Equation (11), and their aspheric coefficients are listed in Table 14 as follows:

TABLE 14

Aspheric coefficients of this preferred embodiment					
	Surface #				
	1	2	4	5	6
k =	5.01344E-01	2.00000E+01	-3.37287E+01	6.38742E-01	8.04940E+00
A4 =	5.80923E-04	-1.71929E-02	-1.44558E-01	-1.51931E-01	-9.03802E-02
A6 =	1.34203E-02	3.53134E-02	1.29822E-01	5.71148E-02	-2.40787E-01

TABLE 14-continued

Aspheric coefficients of this preferred embodiment					
A8 =	-2.00447E-02	5.17815E-02	-1.90141E-01	-3.69484E-02	5.80249E-01
A10 =	4.06848E-02	-1.61866E-01	3.86920E-01	4.24833E-02	-1.41041E+00
A12 =	-2.04723E-02	1.08002E-01	-4.36764E-01	1.50909E-01	1.57713E+00
Surface #					
	7	8	9	10	11
k =	-2.16113E+00	-2.00000E+01	2.00000E+01	-2.00000E+01	-1.11424E+01
A4 =	-1.17821E-01	-3.53736E-02	-1.69724E-02	-2.17953E-01	-9.99872E-02
A6 =	-4.73365E-02	-4.98915E-02	-3.10401E-02	3.93066E-02	2.98735E-02
A8 =	3.98001E-02	8.36341E-02	7.61110E-02	1.48074E-02	-6.86161E-03
A10 =	-2.31086E-03	-1.80145E-02	-4.39385E-02	-3.43509E-03	6.32190E-04
A12 =	3.92033E-03	-1.20726E-02	1.22644E-02	-3.48487E-03	3.29092E-05
A14 =		3.69488E-03	-1.88950E-03	-7.06487E-04	-2.07173E-05
A16 =				4.15543E-04	1.55927E-06

With reference to Table 13 and FIG. 5B for an optical lens for image pickup of this preferred embodiment, the optical lens for image pickup has a focal length $f=4.48$ (mm), an overall aperture stop value (f-number) $Fno=3.22$, and a half of the maximum view angle $HFOV=28.7^\circ$. After the optical data of this preferred embodiment are calculated and derived, the optical imaging system for pickup satisfies related conditions as shown in Table 15 below, and the related symbols have been described above and thus will not be described again.

TABLE 15

Data of related relations of this preferred embodiment			
Relation	Data	Relation	Data
v_1/v_2	2.35	R_7/R_8	-0.66
CT_2/CT_3	0.49	$(R_3 + R_4)/(R_3 - R_4)$	1.57
CT_4/CT_5	0.54	f/f_1	1.47
R_4/f	0.45	f/f_4	0.13
f/R_8	-0.08		

According to the optical data as shown in Table 13 and the series of aberration curves as shown in FIG. 5B, the optical lens for image pickup in accordance with this preferred embodiment of the present invention provides good correction results in aspects of the longitudinal spherical aberration, astigmatic field curving, and distortion.

Sixth Preferred Embodiment

With reference to FIGS. 6A and 6B for a schematic view and a series of aberration curves of an optical lens for image

pickup in accordance with the sixth preferred embodiment of the present invention respectively, the optical lens for image pickup comprises five lens elements, an aperture stop 600 and an IR-filter 660. More specifically, the optical lens for image pickup of the present invention, sequentially arranged from an object side to an image side along an optical axis, comprises: a plastic first lens element 610 with positive refractive power, having a convex object-side surface 611 and a convex image-side surface 612, and both object-side surface 611 and image-side surface 612 being aspheric; an aperture stop 600; a plastic second lens element 620 with negative refractive power, having a convex object-side surface 621 and a concave image-side surface 622, and both object-side surface 621 and image-side surface 622 being aspheric; a plastic third lens element 630 with positive refractive power, having a concave object-side surface 631 and a convex image-side surface 632, and both object-side surface 631 and image-side surface 632 being aspheric; a plastic fourth lens element 640 with positive refractive power, having a convex object-side surface 641 and a convex image-side surface 642, and both object-side surface 641 and image-side surface 642 being aspheric; a plastic fifth lens element 650 with negative refractive power, having a convex object-side surface 651 and a concave image-side surface 652, and both object-side surface 651 and image-side surface 652 being aspheric, and at least one of the object-side surface 651 and the image-side surface 652 having at least one inflection point; and an IR-filter 660 made of panel glass for adjusting a wavelength section of the light of an image. With the combination of the five lens elements, the aperture stop 600 and the IR-filter 660, an image of the photographed object can be formed at the image plane 670.

TABLE 16

Optical data of this preferred embodiment							
$f = 4.45$ mm, $Fno = 3.22$, $HFOV = 28.7$ deg.							
Surface #		Curvature Radius	Thickness	Material	Index	Abbe #	Focal length
0	Object	Plano	Infinity				
1		1.638650 (ASP)	0.573				
2	Lens 1	-27.469360 (ASP)	0.070	Plastic	1.544	55.9	2.86
3	Ape. Stop	Plano	0.071				
4		10.089853 (ASP)	0.414				
5	Lens 2	1.911857 (ASP)	0.209	Plastic	1.634	23.8	-3.80
6		-14.310631 (ASP)	0.718				
	Lens 3			Plastic	1.535	56.3	8.14

TABLE 16-continued

Optical data of this preferred embodiment f = 4.45 mm, Fno = 3.22, HFOV = 28.7 deg.							
Surface #	Curvature Radius	Thickness	Material	Index	Abbe #	Focal length	
7	-3.395472 (ASP)	0.313					
8	10.989011 (ASP)	0.404					
9	-90.090090 (ASP)	0.571	Plastic	1.607	26.6	16.15	
10	17.111567 (ASP)	0.707					
11	2.104890 (ASP)	0.400	Plastic	1.544	55.9	-4.49	
12	Plano	0.210					
13	Plano	0.390	Glass	1.517	64.2	—	
14	Plano	—					

Note:
Reference wavelength is 587.6 nm. ASP stands for aspherical surfaces.

The optical data of this preferred embodiment are listed in Table 16, wherein the object-side surfaces and the image-side surfaces of the first lens element 610 to the fifth lens element 650 comply with the aspheric surface formula as given in Equation (11), and their aspheric coefficients are listed in Table 17 as follows:

TABLE 17

Aspheric coefficients of this preferred embodiment					
	Surface #				
	1	2	4	5	6
k =	3.66023E-01	-1.99951E+01	6.32623E+01	1.09364E+00	-2.00000E+01
A4 =	-4.85078E-03	-1.45884E-02	-1.20935E-01	-1.37739E-01	-8.80160E-02
A6 =	7.11596E-03	3.11616E-02	1.28812E-01	6.72334E-02	-1.82389E-01
A8 =	-2.21036E-02	2.27265E-02	-2.13314E-01	-2.80833E-02	5.65492E-01
A10 =	3.65925E-02	-1.18546E-01	3.89854E-01	-2.97941E-02	-1.27337E+00
A12 =	-2.38189E-02	8.90471E-02	-3.85898E-01	2.62832E-01	1.45486E+00
	Surface #				
	7	8	9	10	11
k =	-4.23008E+00	-1.99999E+01	2.00000E+01	1.65493E+00	-8.32051E+00
A4 =	-1.09047E-01	-4.69959E-02	-3.52395E-02	-2.34936E-01	-1.13465E-01
A6 =	-3.47073E-02	-5.09155E-02	-2.80445E-02	3.97669E-02	3.53511E-02
A8 =	5.54561E-02	8.45530E-02	7.72181E-02	2.05252E-02	-7.80932E-03
A10 =	-2.70381E-03	-1.65643E-02	-4.37089E-02	-3.36388E-03	6.59440E-04
A12 =	1.01805E-02	-1.12117E-02	1.21480E-02	-4.20622E-03	3.74149E-05
A14 =		3.44416E-03	-1.77911E-03	-7.56833E-04	-2.24339E-05
A16 =				6.98503E-04	1.97035E-06

With reference to Table 16 and FIG. 6B for an optical lens for image pickup of this preferred embodiment, the optical lens for image pickup has a focal length f=4.45 (mm), an overall aperture stop value (f-number) Fno=3.22, and a half of the maximum view angle HFOV=28.7°. After the optical data of this preferred embodiment are calculated and derived, the optical imaging system for pickup satisfies related conditions as shown in Table 18 below, and the related symbols have been described above and thus will not be described again.

TABLE 18

Data of related relations of this preferred embodiment			
Relation	Data	Relation	Data
v_1/v_2	2.35	R_7/R_8	-0.12
CT_2/CT_3	0.53	$(R_3 + R_4)/(R_3 - R_4)$	1.47

TABLE 18-continued

Data of related relations of this preferred embodiment			
Relation	Data	Relation	Data
CT_4/CT_5	0.57	f/f_1	1.56
R_4/f	0.43	f/f_4	0.28
f/R_8	-0.05		

According to the optical data as shown in Table 16 and the series of aberration curves as shown in FIG. 6B, the optical lens for image pickup in accordance with this preferred embodiment of the present invention provides good correction results in aspects of the longitudinal spherical aberration, astigmatic field curving, and distortion.

25

In the optical lens for image pickup of the present invention, the lens elements can be made of glass or plastic. For the lens elements made of glass, the optical lens for image pickup can be installed more flexibly. For the lens elements made of plastic, the production cost can be lowered.

As used throughout the specification and claims, in the optical lens for image pickup of the present invention, if the lens element has a convex surface, then the surface of the lens element is convex at a position proximate to the optical axis; and if the lens element has a concave surface, then the surface of the lens element is concave at a position proximate to the optical axis.

In the optical lens for image pickup of the present invention, at least one aperture stop such as a glare stop or a field stop is provided for reducing stray lights to improve the image quality.

In the optical lens for image pickup of the present invention, the aperture stop can be a front or middle aperture stop. If the aperture stop is a front aperture stop, a longer distance between the exit pupil of the optical lens for image pickup and the image plane can be achieved to provide the telecentric effect and improve the efficiency of receiving images by the image sensor such as a CCD or CMOS image sensor. If the aperture stop is a middle aperture stop, the view angle of the system can be increased, such that the optical lens for image pickup has the advantage of a wide-angle lens.

Tables 1 to 18 show changes of values of an optical lens for image pickup in accordance with different preferred embodiments of the present invention respectively, and even if different values are used, products of the same structure are intended to be covered by the scope of the present invention. It is noteworthy to point out that the aforementioned description and the illustration of related drawings are provided for the purpose of explaining the technical characteristics of the present invention, but not intended for limiting the scope of the present invention.

What is claimed is:

1. A plurality of optical lenses for image pickup, sequentially arranged from an object side to an image side, with no intervening lenses, comprising:

a first lens element with positive refractive power having a convex object-side surface;

a second lens element with negative refractive power;

a third lens element with refractive power;

a fourth lens element with positive refractive power having a convex object-side surface and a convex image-side surface, at least one of the object-side surface and the image-side surface being aspheric, and made of plastic; and

a fifth lens element with negative refractive power having a concave image-side surface, and at least one of the object-side surface and the image-side surface being aspheric, having at least one inflection point, and made of plastic;

wherein, R_7 is a curvature radius of the object-side surface of the fourth lens element, R_8 is a curvature radius of the image-side surface of the fourth lens element, and the following relation is satisfied:

$$-1.0 < R_7/R_8 < 0.$$

2. The optical lens for image pickup of claim 1, wherein the second lens element has a concave image-side surface.

26

3. The optical lens for image pickup of claim 2, wherein f is a focal length of the optical lens for image pickup, f_4 is a focal length of the fourth lens element, and the following relation is satisfied:

$$0 < ff_4 < 1.0.$$

4. The optical lens for image pickup of claim 3, wherein R_3 is a curvature radius of the object-side surface of the second lens element, R_4 is a curvature radius of the image-side surface of the second lens element, and the following relation is satisfied:

$$0 < (R_3 + R_4)/(R_3 - R_4) < 1.8.$$

5. The optical lens for image pickup of claim 2, wherein f_1 is a focal length of the optical lens for image pickup, f_1 is a focal length of the first lens element, and the following relation is satisfied:

$$1.2 < ff_1 < 1.8.$$

6. The optical lens for image pickup of claim 5, wherein CT_4 is a central thickness of the fourth lens element, CT_5 is a central thickness of the fifth lens element, and the following relation is satisfied:

$$0.2 < CT_4/CT_5 < 1.4.$$

7. The optical lens for image pickup of claim 2, wherein v_1 is an Abbe number of the first lens element, v_2 is an Abbe number of the second lens element, and the following relation is satisfied:

$$1.7 < v_1/v_2 < 3.0.$$

8. The optical lens for image pickup of claim 7, wherein R_4 is a curvature radius of the image-side surface of the second lens element, f is a focal length of the optical lens for image pickup, and the following relation is satisfied:

$$0 < R_4/f < 1.5.$$

9. The optical lens for image pickup of claim 7, wherein CT_2 is a central thickness of the second lens element, CT_3 is a central thickness of the third lens element, and the following relation is satisfied:

$$0.2 < CT_2/CT_3 < 0.8.$$

10. The optical lens for image pickup of claim 1, wherein R_7 is the curvature radius of the object-side surface of the fourth lens element, R_8 is the curvature radius of the image-side surface of the fourth lens element, and the following relation is satisfied:

$$-0.5 < R_7/R_8 < 0.$$

11. The optical lens for image pickup of claim 1, wherein at least one of the object-side surface and the image-side surface of the fourth lens element has at least one inflection point.

12. A plurality of optical lenses for image pickup, sequentially arranged from an object side to an image side, with no intervening lenses, comprising:

a first lens element with positive refractive power having a convex object-side surface;

a second lens element with negative refractive power having a concave image-side surface;

a third lens element with refractive power having a concave object-side surface;

a fourth lens element with positive refractive power having a convex object-side surface and a convex image-side surface, at least one of the object-side surface and the image-side surface being aspheric, and made of plastic; and

27

a fifth lens element with negative refractive power having a concave image-side surface, and at least one of an object-side surface and the image-side surface being aspheric, at least one of the object-side surface and the image-side surface having at least one inflection point, and made of plastic;

wherein, f is a focal length of the optical lens for image pickup, f_4 is a focal length of the fourth lens element, CT_4 is a central thickness of the fourth lens element, CT_5 is a central thickness of the fifth lens element, R_8 is a curvature radius of the image-side surface of the fourth lens element, and the following relations are satisfied:

$$0 < f/f_4 < 1.0;$$

$$0.2 < CT_4/CT_5 < 1.4; \text{ and}$$

$$-0.7 < f/R_8 < 0.$$

13. The optical lens for image pickup of claim 12, wherein f is the focal length of the optical lens for image pickup, f_1 is a focal length of the first lens element, and the following relation is satisfied:

$$1.2 < f/f_1 < 1.8.$$

14. The optical lens for image pickup of claim 13, wherein v_1 is an Abbe number of the first lens element, v_2 is an Abbe number of the second lens element, and the following relation is satisfied:

$$1.7 < v_1/v_2 < 3.0.$$

15. The optical lens for image pickup of claim 13, wherein R_7 is a curvature radius of the object-side surface of the fourth lens element, R_8 is a curvature radius of the image-side surface of the fourth lens element, and the following relation is satisfied:

$$-0.5 < R_7/R_8 < 0.$$

16. The optical lens for image pickup of claim 14, wherein R_3 is a curvature radius of the object-side surface of the second lens element, R_4 is a curvature radius of the image-side surface of the second lens element, and the following relation is satisfied:

$$0 < (R_3 + R_4)/(R_3 - R_4) < 1.8.$$

17. The optical lens for image pickup of claim 13, wherein the third lens element has a convex image-side surface.

18. A plurality of optical lenses for image pickup, sequentially arranged from an object side to an image side, with no intervening lenses, comprising:

28

a first lens element with positive refractive power having a convex object-side surface;

a second lens element with negative refractive power having a concave image-side surface;

a third lens element with refractive power having a concave object-side surface and a convex image-side surface;

a fourth lens element with positive refractive power having a convex object-side surface and a convex image-side surface, at least one of the object-side surface and the image-side surface being aspheric, and made of plastic; and

a fifth lens element with negative refractive power, at least one of the object-side surface and the image-side surface being aspheric, at least one of the object-side surface and the image-side surface having at least one inflection point, and made of plastic;

wherein f is a focal length of the optical lens for image pickup, f_4 is a focal length of the fourth lens element, R_4 is a curvature radius of the image-side surface of the second lens element, R_8 is a curvature radius of the image-side surface of the fourth lens element, and the following relations are satisfied:

$$0 < f/f_4 < 1.0;$$

$$0 < R_4/f < 1.5; \text{ and}$$

$$-0.7 < f/R_8 < 0.$$

19. The optical lens for image pickup of claim 18, wherein v_1 is an Abbe number of the first lens element, v_2 is an Abbe number of the second lens element, and the following relation is satisfied:

$$1.7 < v_1/v_2 < 3.0.$$

20. The optical lens for image pickup of claim 18, wherein CT_4 is a central thickness of the fourth lens element, CT_5 is a central thickness of the fifth lens element, and the following relation is satisfied:

$$0.2 < CT_4/CT_5 < 1.4.$$

21. The optical lens for image pickup of claim 18, wherein f is the focal length of the optical lens for image pickup, f_1 is a focal length of the first lens element, and the following relation is satisfied:

$$1.2 < f/f_1 < 1.8.$$

22. The optical lens for image pickup of claim 18, wherein CT_2 is a central thickness of the second lens element, CT_3 is a central thickness of the third lens element, and the following relation is satisfied:

$$0.2 < CT_2/CT_3 < 0.8.$$

* * * * *